

Prodigy® Application Guide (Advanced Features)

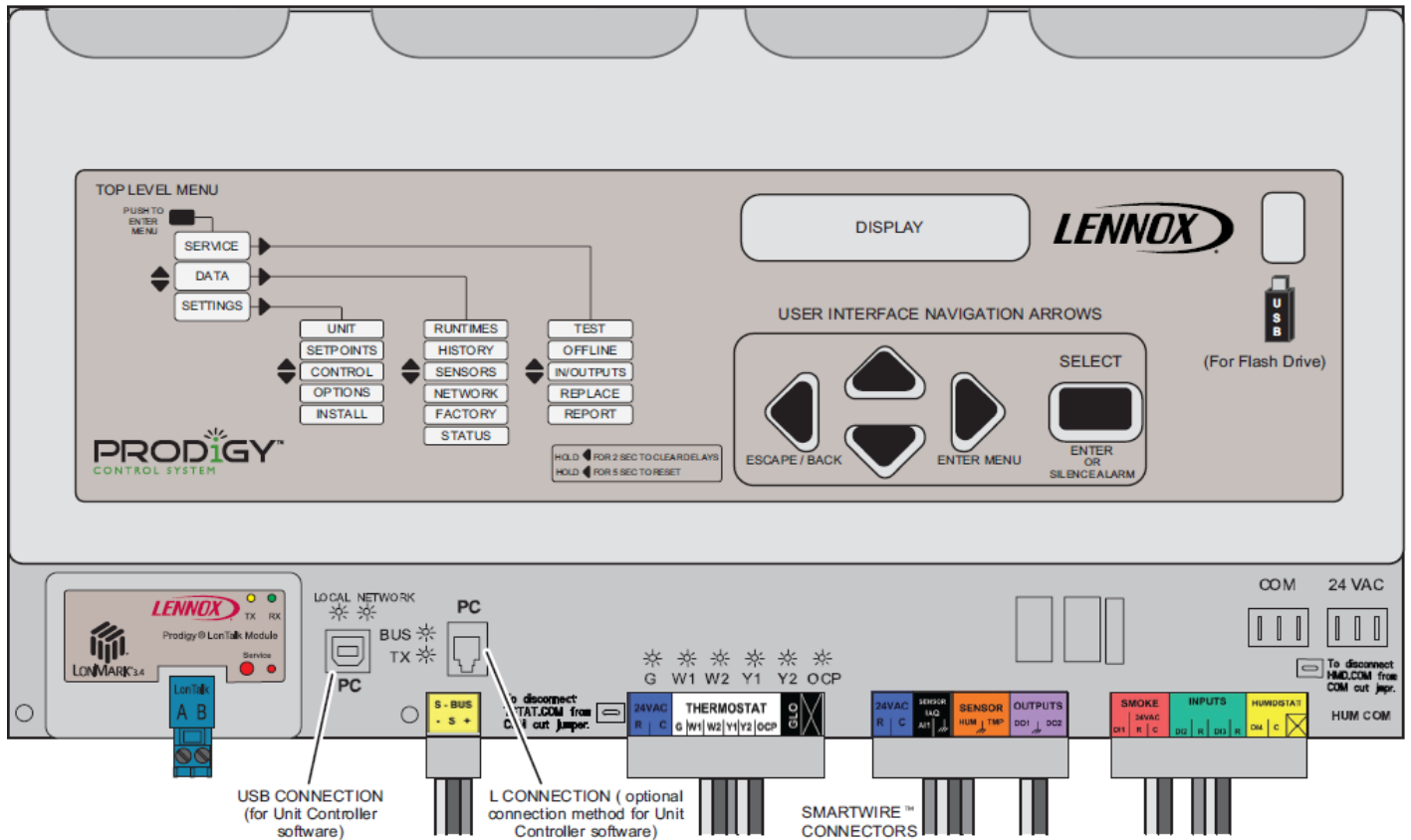

⚠ CAUTION

To insure correct voltage phasing before startup:

- 1) use refrigerant pressure gauges to check proper compressor operation and,
- 2) check arrow label for blower rotation.

Compressor damage will be the responsibility of the installer.

Table Of Contents

1. Prodigy M2 Unit Controller Description	Page 6
1.1. Add-on boards	Page 6
2. Main Controller Operation	Page 7
2.1. System Mode - Thermostat	Page 7
2.1.1. Cooling Stages	Page 7
2.1.2. Heating Stages	Page 7
2.2. System Mode - Zone Sensor	Page 8
2.2.1. Network Control Panel (NCP)	Page 8
2.2.2. Zone Sensor Back-Up Modes	Page 8
2.2.3. L Connection Network Back-Up Set Points	Page 8
2.2.4. Heating & Cooling Stages in Zone Sensor Mode	Page 8
2.2.5. Off Delay in Zone Sensor Mode	Page 9
2.2.6. Blower Operation in Zone Sensor Mode	Page 9
3. Unit Component Operation	Page 12
3.1. Compressor Protection and Delays	Page 12
3.1.1. Compressor Minimum Run Time (3 Phase Units Only)	Page 12
3.1.2. Compressor Off Delay (Single phase units only)	Page 12
3.1.3. Blower On Delay	Page 12
3.1.4. Freeze-stats (S49, S50, S53, S59)	Page 12
3.1.5. High Pressure Switches (S4, S7, S28, S96)	Page 12
3.2. Gas Units Burner Protection And Delays	Page 12
3.2.1. Primary or Secondary Limits (S10, S21, S99, S100, S130, S131)	Page 12
3.2.2. Roll-Out Switch (S47, S69)	Page 12
3.2.3. Combustion Air Switch (S18, S45)	Page 12
3.2.4. Gas Valve Sense	Page 12
3.2.5. Gas Valve Delays	Page 12
3.3. Miscellaneous Components	Page 12
3.3.1. Unoccupied Or Night Setback Mode	Page 12
3.3.2. Local Thermostat Mode	Page 12
3.3.3. Zone Sensor Mode	Page 13
3.3.4. Gas and Electric Heat Warm-Up Mode (During occupied time period)	Page 13
3.3.5. Heat Pump Warm-Up Mode	Page 13
3.3.6. Cool-Down Mode (During occupied time period)	Page 13
3.3.7. Air Flow Switch (S52-Optional)	Page 13
3.3.8. Dirty Filter Switch (S27-Optional)	Page 13
3.4. Gas Heat Operation—Gas Units	Page 13
3.5. Electric Heat Operation—Electric / Electric Units	Page 13
3.5.1. Electric Heat Operation	Page 13
3.5.2. Primary or Secondary Limits	Page 13
3.6. Heat Pump Operation	Page 13
3.6.1. Heat Operation	Page 13
3.6.2. Primary or Secondary Limits	Page 13
3.6.3. Defrost Cycle	Page 13
3.6.4. Supplemental Heat Lock Out	Page 14
3.6.5. Test Supplemental Electric Heat Operation	Page 14
3.6.6. Thermostats With Emergency Heat Function	Page 14
3.7. Low Pressure Switches (S87, S88, S98, S97)	Page 14
3.7.1. Low Pressure Switch Off	Page 14
3.7.2. Ignore Or Shunt Time Period	Page 14
3.7.3. Control De-Energizes Unit	Page 14
3.8. Loss of Power Detection (Single phase units only)	Page 14
3.9. Thermostat Bounce Delay (Local thermostat mode only)	Page 14
3.10. Return Air Temperature Limits	Page 14
3.10.1. Smoke Detector (A17-Optional)	Page 14
3.10.2. Safety Switch Input (A42-Optional)	Page 15
4. Sensors	Page 15
4.1. Temperature Sensors - Provided With Unit	Page 15
4.2. Optional Zone Sensor	Page 15
4.3. Optional Relative Humidity Sensor	Page 15
4.4. Optional CO2 (IAQ) Sensor	Page 16
4.5. Optional Supply Static Pressure Sensor	Page 16
4.6. Optional Building or Return Static Pressure Sensor	Page 16
4.7. Optional Enthalpy Sensor	Page 16
4.8. OAC Sensor	Page 16
5. Low Ambient Fan Cycling	Page 17
5.1. High Efficiency A Box Fan Operation	Page 17
5.2. Low Ambient Fan Cycling - Other Unit	Page 17

6. Reheat Operation	Page 19
6.1. General	Page 19
6.2. Supermarket Reheat Operation	Page 19
6.3. Humiditrol Reheat Operation	Page 20
6.4. Humiditrol Reheat Operation - Digital	Page 20
6.5. RH Measurement / Display	Page 20
6.6. Outside Air For Dehumidification	Page 20
7. Economizer	Page 25
7.1. General	Page 25
7.2. Outdoor Air Suitable (OAS) LED	Page 25
7.3. DIP Switch Settings	Page 25
7.4. Free Cooling Discharge Air Set point	Page 25
7.5. Free Cooling Compressor Lockout Set point	Page 25
7.6. Outdoor Air Suitability	Page 26
7.7. Enthalpy Set point	Page 26
7.8. Damper Minimum Position Potentiometer	Page 27
7.9. Damper Maximum Position	Page 27
7.10. Motorized Outdoor Air Damper	Page 27
7.11. Economizer Checkout	Page 27
7.12. Demand Control Ventilation	Page 29
7.12.1. General	Page 29
7.12.2. Default Operation	Page 30
7.12.3. ECTO Adjustments	Page 30
7.12.3.1. Set point Control Option	Page 30
7.12.3.2. Determine IAQ Input	Page 31
7.12.4. Outdoor Air Control Sensor (OAC)	Page 31
7.12.4.1. Field Wiring	Page 31
7.12.4.2. Set Damper Minimum Position	Page 31
7.12.4.3. Set Velocity Sensor Range	Page 32
7.12.4.4. Set Velocity Set point	Page 32
8. Power Exhaust Operation	Page 34
8.1. Single Fan or Blower	Page 34
8.2. Two Fans or Blowers	Page 34
8.3. Exhaust Blower VFD	Page 34
9. Supply Air Delivery	Page 36
9.1. System Mode	Page 36
9.1.1. Gas / Electric Units:	Page 36
9.1.2. Electric / Electric Units:	Page 36
9.1.3. Cooling Operation:	Page 36
9.1.4. Heat Pump Operation:	Page 36
9.2. Supply VAV Control Mode	Page 36
9.2.1. Local Thermostat Mode, Single Zone CAV Units	Page 36
9.2.2. Zone Sensor mode, Single Zone CAV Units	Page 37
9.2.3. Local Thermostat Mode, CAV Bypass Zoning Units	Page 37
9.2.4. L Connection Network, CAV Bypass Zoning Units	Page 37
9.2.5. Local Thermostat Mode, VAV units	Page 37
9.2.6. Local Thermostat Mode, VAV staged units	Page 38
9.2.7. L Connection Network, VAV units	Page 38
9.2.8. VAV Staged Units: A Box	Page 38
9.2.9. VAV Staged Units: B, C, D, and E Boxes	Page 39
9.3. VFD Control	Page 39
9.4. Supply Bypass Damper Control	Page 39
9.5. Analog Output Control	Page 40
9.5.1. Manual Reset (ManRS)	Page 40
9.5.2. Proportional Constant (P)	Page 40
9.5.3. Integral Constant (I)	Page 40
9.5.4. Derivative Constant (D)	Page 40
9.5.5. Tuning	Page 40
10. Discharge Air Control	Page 42
10.1. Cooling	Page 42
10.2. Outdoor Air Reset	Page 42
10.3. Return Air Reset	Page 43
10.4. Discharge Air Cooling Total Reset Limit	Page 44
10.5. Heating	Page 45
10.6. Outdoor Air Reset	Page 45
10.7. Return Air Reset	Page 46
10.8. Discharge Air Control Heating Total Reset Limit	Page 47
11. Third-Party Zoning	Page 48
11.1. Air Delivery Operation	Page 48
11.2. Occupied /Unoccupied Operation	Page 48

11.3.	Cooling Operation	Page 48
11.4.	DACC Outdoor Air Reset	Page 49
11.5.	DACC Return Air Reset	Page 49
11.6.	Heating Operation	Page 49
11.7.	DACH Outdoor Air Reset	Page 49
11.8.	DACH Return Air Reset	Page 49
11.9.	Power Exhaust Operation	Page 49
11.10.	VAV and CAVB Analog Outputs	Page 49
	11.10.1. VFD Control	Page 49
	11.10.2. Supply Bypass Damper Control	Page 49
11.11.	M2 LonTalk® Module	Page 54
12.	BACnet®	Page 55
12.1.	M2 BACnet™ Module	Page 55
12.2.	Recommendations	Page 55
12.3.	Default Settings	Page 55
12.4.	Analog Output Objects	Page 56
12.5.	Analog Value Objects	Page 56
12.6.	Analog Input Objects	Page 56
13.	Modulating Gas Valve (MGV)	Page 58
13.1.	Operation	Page 58
13.2.	Testing	Page 58
13.3.	M2 Output	Page 58
14.	Load Shedding Options	Page 59
15.	Service Relay	Page 60
15.1.	Service Relay Operation	Page 60
15.2.	OAT Operation	Page 61
16.	Diagnostics	Page 62
16.1.	M2 Event Codes	Page 62
17.	Electronic Configure To Order (ECTO) Control Parameters	Page 66
17.1.	M2 (A55) Push-button And Display	Page 66
17.2.	Reset To Factory ECTO Parameters	Page 66
17.3.	Unit Controller PC Software	Page 66
18.	Networking The Controllers	Page 89
19.	Sequence of Operation	Page 90
19.1.	Unit Controller Control Modes	Page 90
	19.1.1. Unit Controller In Zone Sensor Mode	Page 90
	19.1.2. Unit Controller In Thermostat Mode	Page 90
	19.1.3. Operations Common to All Rooftop Units	Page 91
	19.1.3.1. Heating Operation (Modulating Gas)	Page 91
	19.1.3.2. Occupied Demand	Page 92
	19.1.3.3. Demand Control Ventilation	Page 92
	19.1.3.4. Fresh Air Tempering (FAT)	Page 92
	19.1.3.5. Hot Gas Bypass	Page 92
	19.1.3.6. Discharge Air Cooling Reset Operation	Page 92
	19.1.3.7. Discharge Air Heating Reset Operation	Page 92
	19.1.3.8. Building Pressure Control for Standard or High Static Power Exhaust Fans	Page 92
	19.1.3.9. Damper Position Control	Page 93
	19.1.3.10. Differential Static Pressure Control	Page 93
	19.1.3.11. Building Pressure Control for High Static Power Exhaust Fans with Variable Frequency Drives	Page 93
19.1.4.	Constant Air Volume (CAV) Units in Single Zone Applications with a Lennox Zone Sensor (4 Heat / 4 Cool)	Page 93
	19.1.4.1. Unit Controller Operation	Page 93
	19.1.4.2. Ventilation Demand	Page 93
	19.1.4.3. Cooling Demand	Page 93
	19.1.4.4. Cooling Demand with Economizer	Page 94
	19.1.4.5. Heating Demand (General Operation)	Page 94
	19.1.4.6. Heating Demand (Electric)	Page 94
	19.1.4.7. Humiditrol Dehumidification Operation - Dehumidification Demand	Page 94
	19.1.4.8. Humiditrol Dehumidification Operation - Cooling Demand Only	Page 94
	19.1.4.9. Humiditrol Dehumidification Operation - Cooling and Dehum. Demand	Page 94
19.1.5.	Constant Air Volume (CAV) Units in Single Zone Applications with a Thermostat or Third Party Unit Controller (2 Heat / 2 Cool)	Page 95
	19.1.5.1. Unit Controller Operation	Page 95
	19.1.5.2. Ventilation Demand	Page 95
	19.1.5.3. Cooling Demand	Page 95
	19.1.5.4. Cooling Demand With Economizer	Page 95
	19.1.5.5. Heating Demand (General Operation)	Page 95
	19.1.5.6. Heating Demand (Electric)	Page 95
	19.1.5.7. Humiditrol Dehumidification Operation - Dehumidification Demand	Page 95

19.1.5.8.	Humiditrol Dehumidification Operation - Cooling Demand Only	Page 96
19.1.5.9.	Humiditrol Dehumidification Operation - Cooling and Dehum. Demands ..	Page 96
19.1.6.	Constant Air Volume (CAV) Units in Single Zone Applications with a Thermostat or 3rd Party Unit Controller & Unit Operating in Discharge Air Temperature Control (4 Heat / 4 Cool)	Page 96
19.1.6.1.	Unit Controller Operation	Page 96
19.1.6.2.	Ventilation Demand	Page 96
19.1.6.3.	Cooling Demand	Page 96
19.1.6.4.	Cooling Demand With Economizer	Page 96
19.1.6.5.	Heating Demand (General Operation)	Page 97
19.1.6.6.	Heating Operation (Electric)	Page 97
19.1.7.	Constant Air Volume (CAV) Units in Single Zone Applications with a Thermostat or 3rd Party Unit Controller (2 Heat / 2 Cool)	Page 97
19.1.7.1.	Unit Controller Operation	Page 97
19.1.7.2.	Unit Sequence Of Operation	Page 97
19.1.7.3.	Supply Duct Bypass Damper	Page 97
19.1.8.	Constant Air Volume Units in Bypass (CAVB) Zoning Applications with a 3rd Party Unit Controller and the Unit Operating in Discharge Air Temperature Control (4 Heat / 4 Cool)	Page 97
19.1.8.1.	Unit Controller Operation	Page 97
19.1.8.2.	Unit Sequence of Operation	Page 98
19.1.8.3.	Supply Duct Bypass Damper	Page 98
19.1.9.	Variable Air Volume (VAV) Units in Zoning Applications with a 3rd Party Unit Controller and the Unit Operating in Discharge Air Temperature Control (4 Heat / 4 Cool)	Page 98
19.1.9.1.	Unit Controller Operation	Page 98
19.1.9.2.	Ventilation Demand	Page 98
19.1.9.3.	Cooling Demand	Page 98
19.1.9.4.	Cooling Demand With Economizer	Page 99
19.1.9.5.	Heating demand (general operation)	Page 99
19.1.9.6.	Heating Operation (Electric)	Page 99
19.1.9.7.	Morning Warm Up	Page 99
19.1.9.8.	Outdoor Air CFM Control	Page 99
20.	M2 Unit Controller Inputs and Outputs	Page 100
	Alphabetical Index	Page 105
	Abbreviations	Page 106

1. Prodigy M2 Unit Controller Description

The M2 Unit Controller provides all rooftop unit control functions to insure its safe and reliable operation. It also provides status and diagnostic information to facilitate troubleshooting. The controller's programmable parameters allow adjustment of time delays and set points that enable advanced features.

The default configuration requires a standard room thermostat or direct digital controller (DDC). By changing a single parameter, the M2 can also control the unit from a zone sensor. The M2 Unit Controller can also be configured as a network controller when daisy-chained to the L Connection® Network. To simplify configuration, the M2 may be connected to a PC which has been loaded with Unit Controller software.

1.1. Add-on boards

Add-on boards connect to the main board to build variations according to application or equipment type.

Packaged Unit		A55	A59	A169	A133 VAV	A133 MGV	A133 GP
Models	Box Size	M2 Unit Controller	C2, #3 & 4 Compressor Board	MCB1 Motor Control Board	GP1 Variably Air Volume Board	GP1 Modulating Gas Valve Board	GP1 General Purpose I/O Board
LCH/LGH 036-060 S	A	X		X	O*		O
LCH/LGH 036-060 H	A	X		X			O
LCH/LGH 072 H	A+	X			O*		O
LCH/LGH 092-150 H/S	B	X			O*		O
LCH/LGH 156 H	C	X	X		O*		O
LCH/LGH 180 H	C	X	X		O*		O
LCH/LGH 210 H	C	X	X		O*		O
LCH/LGH 240/300 S	C	X	X		O*		O
LCH/LGH 420-600 H/S	E	X	X		O	O	O

X = required; O = optional; * only CAV Bypass supported, no VFD drives.

Figure 1 shows the M2 integrated modular controller components and the location of the add-on boards.

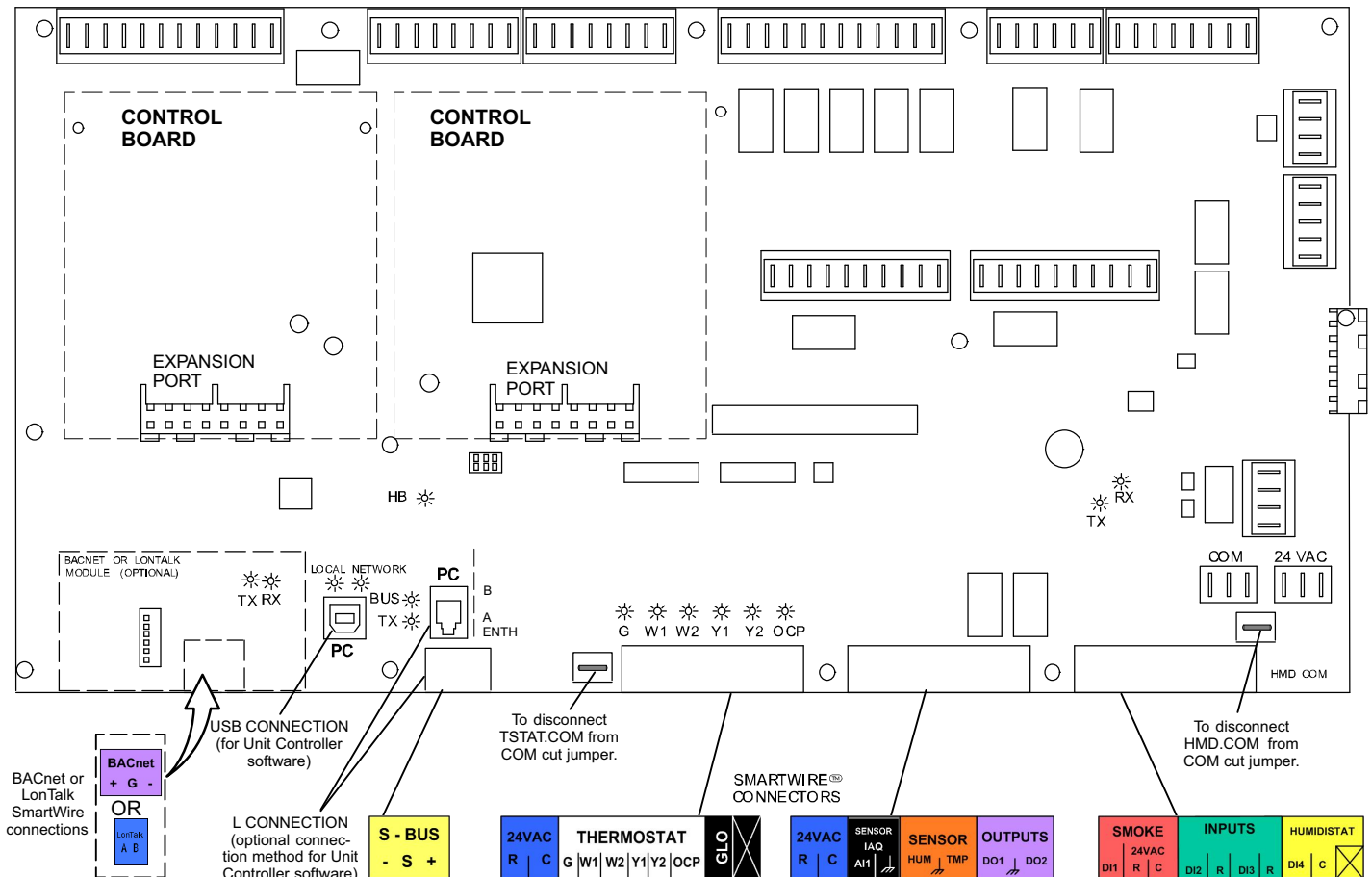

Figure 1. M2 Unit Controller and Expansion Board Locations

2. Main Controller Operation

2.1. System Mode - Thermostat

The M2 will operate the unit from a thermostat, zone sensor, or the zoning system based on the System Mode selected in ECTO 6.01. The default System Mode (option 0) is the thermostat mode.

DDC applications use thermostat mode for two or three-stage cooling and two-stage heating.

Units are shipped from the factory in system mode 0, Thermostat Mode. The M2 will operate two stages of heating and cooling based on the thermostat Y1, Y2, W1, W2, G, and OCP (occupied) demands.

2.1.1. Cooling Stages

The M2 allows three different staging options; adjust ECTO 5.04 to select the option.

- **Option 1. Two Cooling Stages:** Y2 demand brings on all mechanical stages of cooling during economizer operation.
- **Option 2. (Default) Two Cooling Stages:** Cooling operation is shown in table 1. Y2 demand brings 1/2 or 2/3 mechanical stages of cooling during economizer operation.
- **Option 3. Three Cooling Stages:** Cooling operation is shown in table 2; this option requires the use of a three-stage cool thermostat and a K27 relay. See wiring pictorial in figure 2 and wiring diagram control C section.

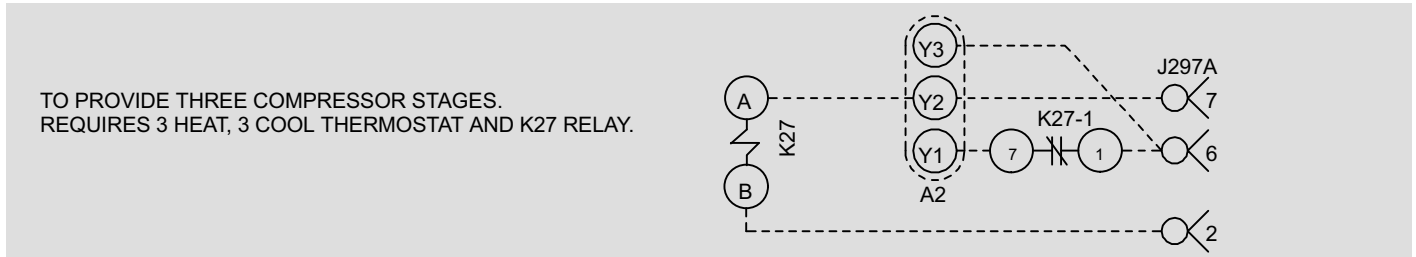

Figure 2. 3-stage cool (ECTO 5.04 opt. 3) wiring

2.1.2. Heating Stages

The M2 default thermostat operation is for two heating stages. See table 3 for gas heat units, table 4 for electric heat units, and table 5 for heat pump units.

Table 1. Thermostat Mode Operation Default (Two Cooling Stages ECTO 5.04 Option 2)

Number of Compressors	No Economizer		With Economizer	
	Y1 Demand	Y2 Demand Adds	Y1 Demand	Y2 Demand Adds
1	CP1	CP1	Free Cool	CP1
2	CP1	CP2	Free Cool	CP1 ⁽¹⁾
3	CP1 + CP2	CP3	Free Cool	CP1 + CP2 ⁽¹⁾
4	CP1 + CP2	CP3 + CP4	Free Cool	CP1 + CP2 ⁽¹⁾

CP1 = Compressor 1, CP2 = Compressor 2, CP3 = Compressor 3, CP4 = Compressor 4.
⁽¹⁾ - ECTO 5.04 option 1 will bring on all available mechanical cooling. *Assumes outdoor air is suitable for cooling.

Table 2. Thermostat Mode Operation (Three Cooling Stages ECTO 5.04 Option 3)

Number of Compressors	No Economizer			With Economizer		
	Y1 Demand	Y2 Demand Adds	Y3 Demand Adds	Y1 Demand	Y2 Demand Adds	Y3 Demand Adds
1	CP1	CP1	CP1	Free Cool	CP1	CP1
2	CP1	CP2	CP2	Free Cool	CP1	CP2
3	CP1	CP2	CP3	Free Cool	CP1	CP2
4	CP1 + CP2	CP3	CP4	Free Cool	CP1 + CP2	CP3

CP1 = Compressor 1, CP2 = Compressor 2, CP3 = Compressor 3, CP4 = Compressor 4. *Assumes outdoor air is suitable for cooling.

Table 3. Default Thermostat Mode Operation (Gas Heat)

No. of Heat Sections	Gas Valve	W1 Demand	W2 Demand
1	(1) 1 Stage	Gas Valve 1	Gas Valve 1
1	(1) 2 Stage	Low Rate	High Rate
2	(2) 1 Stage	High Rate - Both Valves	High Rate - Both Valves
2	(2) 2 Stage	Low Rate - Both Valves	High Rate - Both Valves

Table 4. Default Thermostat Mode Operation (Electric Heat)

No. of Heat Sections	Stages Per Section	W1 Demand	W2 Demand
1	1	Stage 1	Stage 1
1	2	Stage 1	Stage 2
2	1	High Rate - Both Sections	High Rate - Both Sections
2	2	Low Rate - Both Sections	High Rate - Both Sections

Table 5. Thermostat Mode Operation (Heat Pump Heat)

Unit Type	W1 Demand	W2 Demand Adds
1 Compressor / 1 Stage Electric Heat	CP1 Heating	Electric Heat
2 Compressors / 1 Stage Electric Heat	CP1 + CP2 Heating	Electric Heat

2.2. System Mode - Zone Sensor

ECTO 6.01 option 1, 2, or 3 allows the M2 Unit Controller to use internal set points and input from a zone sensor to operate the unit. An additional thermostat or Energy Management System is not required.

Internal set points can be adjusted using the Select button and Arrows on the M2 Unit Controller. Refer to the Electronic Configure To Order (ECTO) section in this manual. In zone sensor mode, during the occupied time period, the default M2 internal heating and cooling set points are:

Cooling set point: 74°F (ECTO 6.04)

Heating set point: 70°F (ECTO 6.02)

Use ECTO stage differential and dead-band options to adjust set points in zone sensor mode.

2.2.1. Network Control Panel (NCP)

The set points can also be adjusted using the optional NCP Network Control Panel. When an NCP is installed, the set points are determined by the NCP schedule. The NCP communicates with the M2 via the L Connection network bus. Internal M2 set points are used only if network communication is interrupted.

The zone sensor is wired directly to each unit P298-6 and P298 -7 (marked GND and TMP on the Field Wiring Termination Plugs). The zone sensor wiring diagram key number is A2.

2.2.2. Zone Sensor Back-Up Modes

Select the appropriate ECTO 6.01 option to determine the zone sensor back-up mode. The back-up mode is used in the event that the A2 room sensor fails or is disconnected.

- Option 1-M2 Zone Sensor System Mode 1 has no back-up mode of control should the A2 zone sensor fail.
- Option 2-M2 Zone Sensor System Mode 2 will default to a local thermostat if one is installed (should the A2 zone sensor fail). The M2 will switch over and operate based on the signals from the room thermostat.
- Option 3-M2 Zone Sensor System Mode 3 will default to return air sensor RT16 (should the A2 zone sensor fail). The M2 will switch over and operate based on the temperature from the return air sensor. RT16 is standard on all units; therefore M2 Zone Sensor System Mode 3 is the recommended System Mode when units are setup in the zone sensor mode.

NOTE - The RT16 has a lower resolution than the A2 zone sensor and should only be used as back-up.

2.2.3. L Connection Network Back-Up Set points

ECTO 6.02 through 6.05 back-up set points are used when the communication link has been lost on the L Connection system bus. Five minutes after communication is interrupted, the M2 will reset and start using the back-up set points. The M2 will default to occupied (6.02 & 6.04) back-up set points when the factory-installed jumper between P297-1 and P297-8 (marked "R" and "OCP" on the P297 label) is left in place.

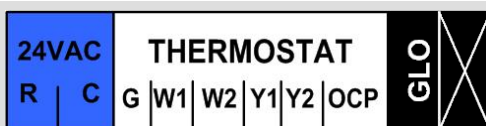

It is recommended that occupied back-up set points be used. If the unoccupied (6.03 & 6.05) back-up set points are desired, remove the factory-installed jumper between P297-1 and P297-8.

During normal zone sensor operation with an NCP, the occupied demands are sent over the network and the occupied input on P297-8 is ignored. The occupied input on P297-8 is only read if the network communication link is lost.

2.2.4. Heating & Cooling Stages in Zone Sensor Mode

In Zone Sensor Mode, default operation, the M2 controls up to 4 stages of heating and 4 stages of cooling. See figure 3 and ECTO parameters in table 6.

The number of stages achieved depends on the type of equipment and whether or not an economizer is used. On units with economizers, free cooling becomes stage 1 and all compressor stages shift up one stage. On units with 4 compressors and an economizer, compressors 3 and 4 are controlled together for stage 4. See figure 3 and the ECTO parameters in table 6.

2.2.5. Off Delay in Zone Sensor Mode

In Zone Sensor Mode, the M2 initiates a 2-minute off delay on any power-up or reset. During the 2-minute delay, no blower, heating, or cooling operation will occur. This delay may be adjusted to stagger the start of each unit, reducing the initial power demand. (ECTO 5.25).

2.2.6. Blower Operation in Zone Sensor Mode

In Zone Sensor Mode, default operation, the M2 cycles the blower with a heat/cool demand. ECTO 6.17 can be changed to allow continuous blower operation.

Table 6. Zone Sensor ECTO Summary

Control Parameter		Control Value			Units	Description
No.	Name	Min.	Default	Max		
Heat Pump Heating						
1.18	Sup_HT_1_Diff	0 0	8 2	15 3.75	Counts W:DegF	Supplemental heat stage 1 differential. Used in zone sensor applications. Note: Differential temperature must be = to or < ECTO 1.19.
1.19	Sup_HT_2_Diff	0 0	12 3	15 3.75	Counts W:DegF	Supplemental heat stage 2 differential. Used in zone sensor applications. Note: Differential temperature must be = to or > ECTO 1.18
1.20	Sup_HT_1_Latch_Option	0	0	1	Option	Supplemental heat stage 1 latch option. Used in zone sensor applications. 0: Latch Disabled 1: Latch Enabled
1.21	Sup_HT_2_Latch_Option	0	0	1	Option	Supplemental heat stage 2 latch option. Used in zone sensor applications. 0: Latch Disabled 1: Latch Enabled
1.22	Sup_HT_1_StgUp_Timer	0 0	0 0	225 3600	Counts F:Sec	Supplemental heat stage 1 stage-up timer. The maximum time that stage 1 runs before calling supplemental heat stage 1. Used in zone sensor applications. Disabled if set to 0.
1.23	Sup_HT_2_StgUp_Timer	0 0	0 0	225 3600	Counts F:Sec.	Supplemental heat stage 2 stage-up timer. The maximum time that supplemental heat 1 runs before calling supplemental heat stage 2. Used in zone sensor applications. Disabled if set to 0.
1.24	StgDn_Timer	0 0	19 304	225 3600	Counts F:Sec	Time delay before a lower stage turns off following a higher stage termination. Used in zone sensor applications.
Electric Heat						
2.06	Stg_Latch_Option	0	0	1	Option	Stage latch option. Used in zone sensor applications. 0: Latch Disabled 1: Latch Enabled
2.07	StgUp_Timer	0 0	57 912	225 3600	Counts F:Sec	Stage up timer. The maximum time that lower stage runs before calling next heat stage. Used in zone sensor applications. Disabled if set to 0.
2.08	StgDn_Timer	0 0	0 0	225 3600	Counts F: Sec	Time delay before a lower stage turns off following a higher stage termination. Used in zone sensor applications.
Gas Heat						
3.10	Stg_Latch_Option	0	0	1	Option	Stage latch option. Used in zone sensor applications. 0: Latch Disabled 1: Latch Enabled
3.11	StgUp_Timer	0 0	57 912	225 3600	Counts F: Sec	Stage-up timer. The maximum time that lower stage runs before calling next heat stage. Used in zone sensor applications. Disabled if set to 0.
3.12	StgDn_Timer	0 0	0 0	225 3600	Counts F: Sec	Time delay before a lower stage turns off following a higher stage termination. Used in zone sensor applications.
Cooling						
4.17	Stg_2_Latch	0	0	1	Option	Stage 2 latch option. Used in zone sensor applications. 0: Latch Disabled 1: Latch Enabled
4.18	Stg_3_Latch	0	0	1	Option	Stage 3 latch option. Used in zone sensor applications. 0: Latch Disabled 1: Latch Enabled
4.19	Stg_4_Latch	0	0	1	Option	Stage 4 latch option. Used in zone sensor applications. 0: Latch Disabled 1: Latch Enabled
4.20	Stg_2_StgUp_Timer	0 0	57 912	225 3600	Counts F:Sec	Stage 2 stage up timer. The maximum time that cooling stage 1 runs before calling cooling stage 2. Used in zone sensor applications. Disabled if set to 0.

table continued on next page

Control Parameter		Control Value			Units	Description
No.	Name	Min.	Default	Max		
4.21	Stg_3_StgUp_Timer	0 0	57 912	225 3600	Counts F:Sec	Stage 3 stage up timer. The maximum time that cooling stage 2 runs before calling cooling stage 3. Used in zone sensor applications. Disabled if set to 0.
4.22	Stg_4_StgUp_Timer	0 0	57 912	225 3600	Counts F:Sec	Stage 4 stage up timer. The maximum time that cooling stage 3 runs before calling cooling stage 4. Used in zone sensor applications. Disabled if set to 0.
4.23	StgDn_Timer	0 0	57 912	225 3600	Counts F:Sec	Time delay before a lower stage turns off following a higher stage termination. Used in zone sensor applications.
General						
5.25	Zone_Sensor_StartUp_Delay	15 2	15 2	225 30	Counts C:Min.	Start-up demand delay. Holds off all unit operation zone sensor and CAVB applications. Hold off FAH-Reheat, FAC, FAH options and all GP outputs. May be used to stagger unit start-ups. Does NOT delay demands in thermostat mode.
6.01	System_Mode	0	0	12	Option	System mode of operation. Control Value System Mode Backup Mode 0 Local Thermostat None 1 Zone Sensor None 2 Zone Sensor Local Thermostat 3 Zone Sensor Return Air Sensor 4 Remote Demand None 5 Remote Demand Local Thermostat 6 Remote Demand Return Air Sensor 7 Remote Demand Zone Sensor
6.02	OCP_HT_BkUp_SP	20 95	120 70	240 40	Counts Z:DegF	Backup occupied heating set point. Used if the communications link is lost for 5 minutes between the M2 and NCP. Used only with zone sensor applications. Set point temperature must be < or = (6.04 - 6.15).
6.03	UnOcp_HT_BkUp_SP	20 95	160 60	240 40	Counts Z:DegF	Backup unoccupied heating set point. Used if the communications link is lost for 5 minutes between the M2 and NCP. Used only in zone sensor applications. Set point temperature must be < or = (6.05 - 6.15).
6.04	Ocp_CL_BkUp_SP	20 95	100 75	240 40	Counts Z:DegF	Backup occupied cooling set point. Used if the communications link is lost for 5 minutes between the M2 and NCP. Used only in zone sensor applications. Set point temperature must be > or = (6.02 + 6.15).
6.05	UnOcp_CL_BkUp_SP	20 95	60 85	240 40	Counts Z:DegF	Backup unoccupied cooling set point. Used if the communications link is lost for 5 minutes between the M2 and NCP. Used only in zone sensor applications. Set point temperature must be > or = (6.03 + 6.15).
6.06	Override_Timer	0 0	28 3584	225 28800	Counts E: Sec	After hours override timer. Only used on zone sensor applications without a Network Control Panel (NPC).
6.07	HT_Stg_DB	4 1	4 1	15 3.75	Counts W:DegF	Heating dead-band. Used only with M2 zone sensor applications. Dead-band must be < or = 6.15 - 6.08.
6.08	CL_Stg_DB	4 1	4 1	15 3.75	Counts W:DegF	Cooling dead-band. Used only with zone sensor applications. Dead-band must be < or = 6.15 - 6.07.
6.09	Stg_1_HT_Dif	0 0	2 0.5	12 3	Counts W:DegF	Heating stage 1 differential. Used only with zone sensor applications. Differential temperature must be < or = 6.11.
6.10	Stg_1_CL_Dif	0 0	2 0.5	12 3	Counts W:DegF	Cooling stage 1 differential. Used only with zone sensor applications. Differential temperature must be < or = 6.12.
6.11	Stg_2_HT_Dif	0 0	4 1	12 3	Counts W:DegF	Heating stage 2 differential. Used only with zone sensor applications. Differential temperature must be > or = 6.09.
6.12	Stg_2_CL_Dif	0 0	4 1	12 3	Counts W:DegF	Cooling stage 2 differential. Used only with zone sensor applications. Differential temperature must be > or = 6.10 AND < or = 6.13.
6.13	Stg_3_CL_Dif	0 0	6 1.5	12 3	Counts W:DegF	Cooling stage 3 differential. Used only with zone sensor applications. Differential temperature must be > or = 6.12 AND < or = 6.14.
6.14	Stg_4_CL_Dif	0 0	8 2	12 3	Counts W:DegF	Cooling stage 4 differential. Used only with zone sensor applications. Differential temperature must be > or = 6.13.
6.15	Zone_Sensor Autochangeover DB_Min	8 2	12 3	40 10	Counts W:DegF	Minimum autochangeover dead-band temperature. Dead-band must be > or = (6.07 + 6.08). Used in zone sensor applications.

Units With Economizer:

C1=Free Cooling
 C2=Compressor 1
 C3=Compressor 2
 C4=Compressor 3 + 4

C1=Cooling Stage 1
 C2=Cooling Stage 2
 C3=Cooling Stage 3
 C4=Cooling Stage 4

H1=Heating Stage 1
 H2=Heating Stage 2
 H3=Heating Stage 3
 H4=Heating Stage 4

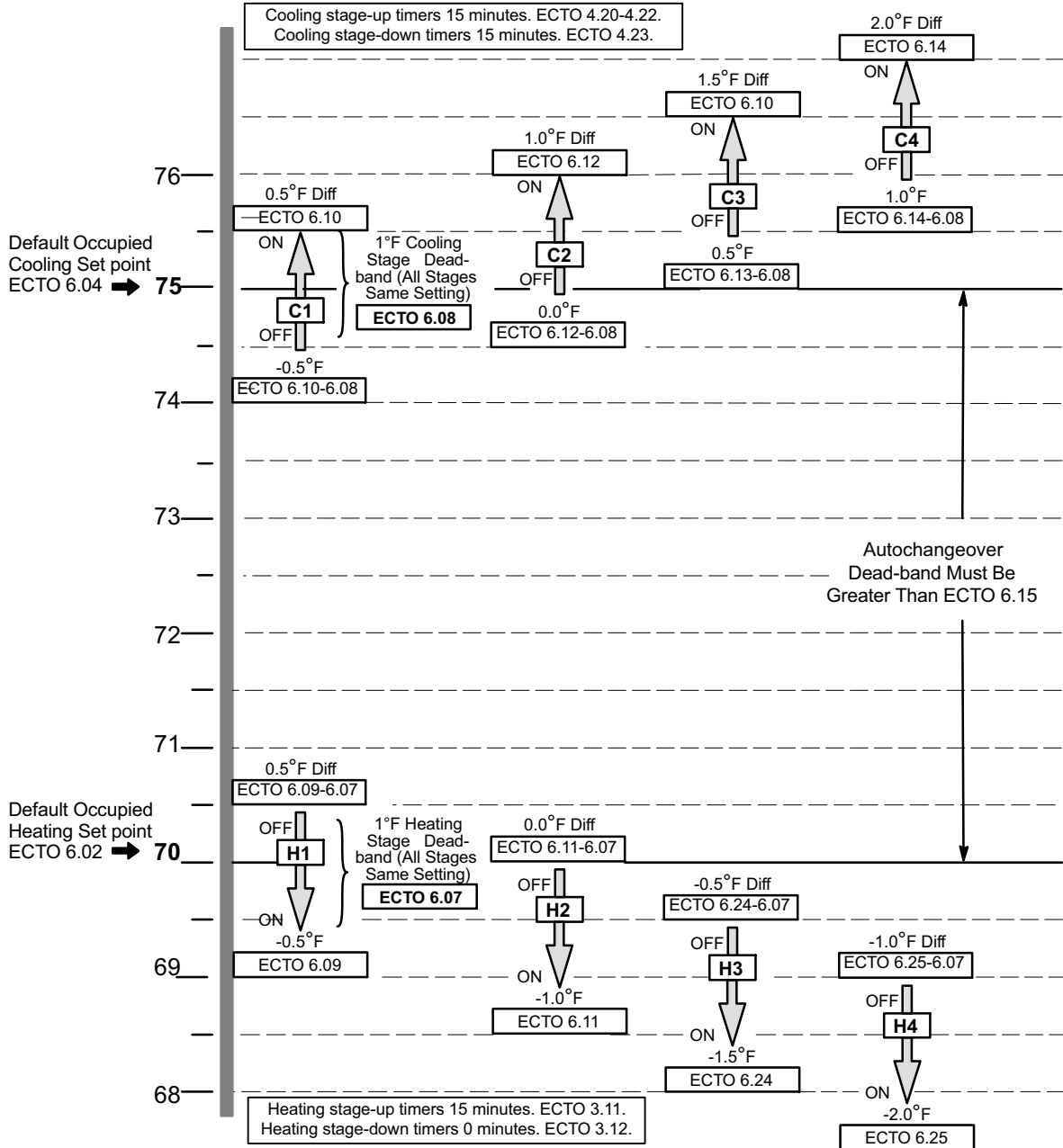

Figure 3. Zone Sensor Stages For Gas / Electric Units (Default Values Shown)

3. Unit Component Operation

3.1. Compressor Protection and Delays

3.1.1. Compressor Minimum Run Time (3 Phase Units Only)

Each compressor stage has a minimum run time of four minutes (ECTO 1.11, 4.13).

3.1.2. Compressor Off Delay (Single phase units only)

Compressors have a five minute (default) compressor off delay. (ECTO 1.10, 4.12).

3.1.3. Blower On Delay

On gas units, the blower is delayed 40 seconds (default) after the gas valve is energized. There is no blower delay on cooling and heat pump units (ECTO 1.02, 2.02, 3.02, 4.02).

3.1.4. Freeze-stats (S49, S50, S53, S59)

Normally closed freeze stats open when evaporator coil temperature drops to de-energize the corresponding compressor. Once coil temperature rises the switch automatically resets to allow compressor operation. The corresponding compressor is locked out after three occurrences. (ECTO 4.04).

3.1.5. High Pressure Switches (S4, S7, S28, S96)

High pressure switches open on a pressure rise to de-energize the corresponding compressor for five minutes (ECTO 5.02). Switches automatically reset when pressure drops. The corresponding compressor is locked out after three occurrences. (ECTO 4.14).

3.1.6. High Temperature Switches (compressor internal)

High temperature switches open on a temperature rise to de-energize the corresponding compressor. Switches automatically reset when temperature drops.

On certain compressors, these switches are in series with the high pressure switches, and will cause a five minute (ECTO 5.02) off period, and an alarm code. The corresponding compressor is locked out after three occurrences of either high pressure or high temperature conditions during a demand cycle (ECTO 4.14).

3.2. Gas Units Burner Protection And Delays

3.2.1. Primary or Secondary Limits (S10, S21, S99, S100, S130, S131)

If primary or secondary limits open during heating, the M2 will de-energize the gas valve and energize the blower. If primary or secondary limits open three times during a thermostat cycle, the heat section operation will be locked-out for one hour.

3.2.2. Roll-Out Switch (S47, S69)

If roll-out switch opens, the gas valve will be de-energized and a manual reset is required to restart.

3.2.3. Combustion Air Switch (S18, S45)

If the combustion air switch opens during heating the gas valve is de-energized. If the combustion air switch opens 3 (default) times, the service alarm output will turn on.

3.2.4. Gas Valve Sensor

If the gas valve is not energized 2 minutes after a heating demand, the M2 will display and store error code 58 for gas valve 1 and 68 for gas valve 2.

If the gas valve is energized and de-energized 3 (default) times during a single heating demand, the M2 will display and store error code 59 for gas valve 1 and 69 for gas valve 2. The service relay will be activated.

The M2 will also de-energize all outputs and turn on the service output if the gas valve is energized without a heating demand.

3.2.5. Gas Valve Delays

The M2 has a 30 second (default) delay between first and second stages. A timed off delay (100 seconds default) will prevent gas heat operation until 100 seconds has passed from the previous cycle. (ECTO 3.05, 3.06).

3.3. Miscellaneous Components

3.3.1. Unoccupied Or Night Setback Mode

During the unoccupied time period dampers do not operate at minimum position (no minimum ventilation requirements during unoccupied period).

3.3.2. Local Thermostat Mode

The unoccupied time period occurs when there is no input at A55_P297-8.

3.3.3. Zone Sensor Mode

The occupied time period is controlled by the optional NCP when installed. The A55_P297-8 input is ignored while in the zone sensor mode except during back-up operation.

3.3.4. Gas and Electric Heat Warm-Up Mode (During occupied time period)

Many building codes require a percentage of fresh outdoor air when a conditioned space is occupied. A 24 vac input at unit A55_P297-8 energizes the "occupied" (usually daytime) time period. A field-provided and -installed thermostat or energy management system provides the input.

The first 60 minutes (default) of the **first** heating demand of the occupied time period is called the "warm-up mode".

During the warm-up mode the M2 keeps economizer dampers closed to conserve energy. (ECTO 2.01, 3.01).

The warm-up mode may be bypassed by pressing the left push-button of the display until "CLR DLY" is seen.

3.3.5. Heat Pump Warm-Up Mode

The default M2 setting allows supplemental heat to be used during warm-up mode. Supplemental heat may be locked out during warm-up mode for energy savings in two different ways. See the Electronic Configure to Order Control Parameters section to lock out supplemental heat during warm-up. ECTO 1.01, 1.17.

3.3.6. Cool-Down Mode (During occupied time period)

To conserve energy, the M2 ignores second-stage cooling demand and the economizer opens the first 30 minutes (default) **OR** one cooling cycle (whichever happens first) when the occupied time period starts. The cool-down mode applies only when outdoor air is suitable for free cooling. ECTO 4.01.

The cool-down mode may be bypassed by pressing the left push-button of the display until "CLR DLY" is seen.

3.3.7. Air Flow Switch (S52-Optional)

The air flow switch closes during normal unit operation. If air flow is interrupted 16 seconds after blower demand, S52 opens and the M2 de-energizes the compressor, gas valves, electric heat, and closes economizer damper. The service alarm output will turn on.

3.3.8. Dirty Filter Switch (S27-Optional)

The dirty filter switch is open during normal unit operation. A dirty filter will close S27 and the M2 will display and store the error code and turn on the service alarm output.

3.4. Gas Heat Operation—Gas Units

The M2 has gas heat output control for up to two gas heat burners with two-stage gas valves. A first-stage heat demand energizes the gas valve low fire and a second-stage heat demand energizes the high fire. On units that have two heat sections, a first-stage heat demand energizes low fire on both gas valves and a second-stage heat demand energizes high fire on both gas valves.

3.5. Electric Heat Operation—Electric / Electric Units

3.5.1. Electric Heat Operation

First-stage heating demand energizes first-stage electric heat (K15 and K17). Second-stage heating demand energizes second-stage electric heat (K16 and K18). When first-stage and second-stage heating demands are simultaneous, a 12-second delay will occur between stage one and stage two (ECTO 2.05).

3.5.2. Primary or Secondary Limits

If an electric heat limit (S15 or S63) opens, electric heat is de-energized.

If an electric heat limit opens three times during a thermostat cycle, the service alarm output will turn on (ECTO 2.04).

3.6. Heat Pump Operation

3.6.1. Heat Operation

First-stage heating demand energizes compressor(s) for first-stage heating. Second-stage heating demand energizes supplemental electric heat via K15, K16, K17, and K18 electric heat contactors. K15 and K17 are energized immediately; K16 and K18 are energized after a 12-second delay (ECTO 1.05).

3.6.2. Primary or Secondary Limits

If an electric heat limit (S15 or S63) opens, electric heat is de-energized.

If an electric heat limit opens five times during a thermostat cycle, the service alarm output will turn on (ECTO 1.04).

3.6.3. Defrost Cycle

Defrost is initiated when the defrost temperature switch (S6 or S9) closes. Defrost terminates either when defrost pressure switch (S46 or S104) opens or when 15 minutes (default) has elapsed. (ECTO 1.16). The defrost cycle is **not** terminated when a thermostat demand ends. Only one defrost cycle is allowed for every 60 minutes (default) of run time. (ECTO 1.15).

The first stage of supplemental electric heat is energized when defrost is initiated (default). In units with multiple refrigerant circuits, supplemental electric heat is energized with each defrost circuit. (ECTO 1.14).

NOTE - If ECTO 1.14 is set to "0", there will be no supplemental heat during defrost.

Economizer dampers close during a defrost cycle.

3.6.4. Supplemental Heat Lock Out

The M2 will not allow the delayed (K16 and K18) bank of electric heat to be energized if the outdoor temperature is above 30°F default (ECTO1.06).

The M2 will not allow any banks of electric heat to energize when outdoor air temperature is above 40°F default (ECTO 1.07).

3.6.5. Test Supplemental Electric Heat Operation

To test the operation of supplemental electric heat at outdoor temperatures above 40°F (default), turn on W2 input only (emergency heat). See "Testing Unit Function" section. Supplemental electric heat will be energized. To test supplemental heat with compressor operating, disconnect outdoor air temperature sensor RT17.

3.6.6. Thermostats With Emergency Heat Function

When ONLY the W2 thermostat input is energized, the M2 will lock-out compressor operation and energize only electric heat. Electric heat temperature lock-outs are also ignored.

3.7. Low Pressure Switches (S87, S88, S98, S97)

Low pressure switches may trip during lower outdoor temperatures, especially with longer time periods between compressor cycling. Each compressor stage has the strike three control feature. The strike three control has three functions:

1. De-energizes the compressor for five minutes (default) if the low pressure switch trips (once the ignore time period is elapsed).
2. Ignores the low pressure switch for a specified period of time after thermostat demand.
3. Locks out the compressor stage if the low pressure switch trips three times within the same thermostat demand (once the ignore time period is elapsed).

3.7.1. Low Pressure Switch Off

Once the ignore time period has passed, the low pressure switch will de-energize the compressor. The M2 will prevent compressor operation for five minutes. See ECTO parameter 5.02 to change compressor off time interval.

NOTE - Low pressure switches are ignored on heat pump units during heating.

3.7.2. Ignore or Shunt Time Period

The specified time period varies according to compressor off time and the outdoor ambient temperature. See chart below for low pressure ignore default times and temperatures and the electronic configure to order (ECTO) parameter used to adjust the ignore time period.

		Compressor Off Time ECTO 5.14	
		Short < 4 Hrs	Long ≥ 4 Hrs
Ambient Temperature ECTO 5.15	Cold < 70° F	5 Minutes ECTO 5.13	12 Minutes ECTO 5.11
	Hot ≥ 70° F	2 Minutes ECTO 5.12	6 Minutes ECTO 5.10

3.7.3. Control De-Energizes Unit

If the low pressure switch trips three times (default) during a thermostat demand, the M2 will lock out the compressor. The number of times required to de-energize the unit is adjustable. (ECTO 1.13, 4.15).

3.8. Loss of Power Detection (Single phase units only)

The M2 will turn off compressors for five minutes (default) if a loss of power is detected for two cycles. This indicates a problem with supply voltage; waiting five minutes allows pressures to equalize ensuring start-up. (ECTO 5.02).

3.9. Thermostat Bounce Delay (Local thermostat mode only)

The M2 will ignore room thermostat inputs for three seconds to prevent sporadic cycling.

3.10. Return Air Temperature Limits

Zone temperatures may be limited by changing ECTO parameter 5.05. Change ECTO 5.06 to interrupt a heating demand and ECTO 5.07 to interrupt a cooling demand. If return air temperatures are exceeded, the demand will be interrupted. Error codes 40 or 41 are displayed but not stored in memory for recall.

3.10.1. Smoke Detector (A17-Optional)

If smoke detector senses smoke, normally opened contacts close. The M2 turns off the unit and closes the economizer dampers. Variations in damper position and power exhaust and blower operation may be changed (ECTO 5.01). See table 7.

3.10.2. Safety Switch Input (A42-Optional)

The M2 has a 24 volt optional input (DI-3) which may be used for additional safety switches (such as a blower overload, loss of phase protector, or supply duct high pressure limit switch). Wire the safety switch in series with the input. When the input is de-energized, the M2 will turn off all outputs and display error code #20 (ECTO 5.08). For normal operation, the input must be energized with 24VAC.

Table 7. Smoke Alarm Operation

ECTO 5.01	Blower	Exhaust Fan		Fresh Air Damper	Description
		Single/Two Stage (2)	VFD		
0	Off	Off	Off	Closed	Unit Off
1	On (1)	Off	Off	Open	Positive Pressure
2	On (1)	On	Speed = ECTO 8.19	Closed	Negative Pressure w/ Blower Exhaust fan at fixed speed
3	On (1)	On	Speed = ECTO 8.19	Open	Purge Exhaust fan at fixed speed
4	Off	On	Speed = ECTO 8.19	Closed	Negative Pressure Exhaust fan at fixed speed
5	On (1)	On	Building Static SP=ECTO 8.19	Closed	Negative Pressure w/ Blower Exhaust fan modulates
6	On (1)	On	Building Static SP=ECTO 8.19	Open	Purge Exhaust fan modulates
7	Off	On	Building Static SP=ECTO 8.19	Closed	Negative Pressure Exhaust fan modulates

(1)-Blower with VFDs operation depends on ECTO 0.01 settings. If set to PID, supply static SP = ECTO 0.02, if set to staged, blower speed = ECTO 0.02. For CAV units with bypass dampers, supply static SP= ECTO 0.13.

(2)-Both exhaust fan stages will operate on units with two stage fans.

4. Sensors

The M2 is only compatible with L connections sensors provided with the unit or purchased separately as specified in the Engineering Handbook.

IMPORTANT - All 0-10Vdc sensors require two separate twisted pair cables with shield. one cable is used for the 24Vac power and one cable is used for the 0-10Vdc output. Zone sensors require a single twisted pair cable with shield. The shield drain wires must be connected to the common at the unit field wiring terminal block only. The shield drain wires must not be connected to common at the sensor.

4.1. Temperature Sensors - Provided With Unit

The return air (RT16) and discharge air (RT6) duct probes and the outdoor air (RT17) are all two wire thermistors. The resistance vs. temperature table is shown below:

Temp. °F (°C)	Resistance +/-2%	Temp. °F (°C)	Resistance +/-2%	Temp. °F (°C)	Resistance +/-2%
-40 (-40.0)	335,671	40 (4.4)	26,106	90 (32.2)	7,332
-20 (-28.9)	164,959	50 (10.0)	19,904	100 (37.8)	5,826
0 (-17.8)	85,323	60 (15.6)	15,313	120 (48.9)	3,756
20 (-6.7)	46,218	70 (21.1)	11,884	130 (54.4)	3,047
30 (-1.1)	34,566	80 (26.7)	9,298		

4.2. Optional Zone Sensor

Zone sensors (A2) are two wire thermistor with 1k series resistor.

Temp. °F (°C)	Resistance +/-2%	Temp. °F (°C)	Resistance +/-2%	Temp. °F (°C)	Resistance +/-2%
40 (4.4)	27,102	60 (15.6)	16,313	80 (26.7)	10,299
45 (7.2)	23,764	65 (18.3)	14,474	85 (29.4)	9,249
50 (10.0)	20,898	70 (21.1)	12,882	90 (32.2)	7,529
55 (12.8)	18,433	75 (23.9)	11,498		

4.3. Optional Relative Humidity Sensor

The indoor Rh sensor (A91) is an analog sensor with a 0-10 Vdc output over an Rh range of 0-100%rh. The sensor is powered with 24Vac.

4.4. Optional CO₂ (IAQ) Sensor

The indoor CO₂ sensor (A63) is an analog sensor with a 0-10Vdc output over a CO₂ range of 0-2000ppm as shown in the following table. The sensor is powered with 24Vac.

CO ₂ PPM	DC Voltage	CO ₂ PPM	DC Voltage	CO ₂ PPM	DC Voltage	CO ₂ PPM	DC Voltage
0	0	600	3.0	1200	6.0	1800	9.0
200	1.0	800	4.0	1400	7.0	2000	10.0
400	2.0	1000	5.0	1600	8.0		

4.5. Optional Supply Static Pressure Sensor

The supply duct differential static pressure sensor (A30) is an analog sensor with a 0-10Vdc output over a range of 0-5"w.c as shown in the following table. The sensor is powered with 24Vac.

Pressure "w.c.	DC Voltage	Pressure "w.c.	DC Voltage	Pressure "w.c.	DC Voltage	Pressure "w.c.	DC Voltage
0	0	1.5	3.0	3.0	6.0	4.5	9.0
0.5	1.0	2.0	4.0	3.5	7.0	5.0	10.0
1.0	2.0	2.5	5.0	4.0	8.0		

4.6. Optional Building or Return Static Pressure Sensor

The building static differential static pressure sensor (A34) is an analog sensor with a 0-10Vdc output over a range of -0.5 to 0.5"w.c as shown in the following table. The sensor is powered with 24Vac.

Pressure "w.c.	DC Voltage	Pressure "w.c.	DC Voltage	Pressure "w.c.	DC Voltage	Pressure "w.c.	DC Voltage
-0.5	0	-0.2	3.0	0.1	6.0	0.4	9.0
-0.4	1.0	-0.1	4.0	0.2	7.0	0.5	10.0
-0.3	2.0	0.0	5.0	0.3	8.0		

4.7. Optional Enthalpy Sensor

The optional enthalpy sensors (A7 and A63) used with the economizer have an output of 4-20ma. The sensor is powered with 24Vac. See figure 13 (Page 29).

4.8. Optional Outdoor Air Control (OAC) Sensor

The optional outdoor air control sensor is an analog sensor with a 0-10Vdc output. Three velocity ranges are available (see table 8). The sensor is powered with 24Vac.

Table 8. OAC Sensor Velocity Ranges

Sensor Volts	M2 Readout	0-5m/sec		0-7.5 m/sec		0-10 m/sec	
		m/sec.	ft/min.	m/sec.	ft/min.	m/sec.	ft/min.
0.00	0	0.00	0	0.00	0	0.00	0
0.50	5	0.25	49	0.38	74	0.50	98
1.00	10	0.50	98	0.75	148	1.00	197
1.50	15	0.75	148	1.13	221	1.50	295
2.00	20	1.00	197	1.50	295	2.00	394
2.50	25	1.25	246	1.88	369	2.50	492
3.00	30	1.50	295	2.25	443	3.00	590
3.50	35	1.75	344	2.63	517	3.50	689
4.00	40	2.00	394	3.00	590	4.00	787
4.50	45	2.25	443	3.38	664	4.50	886
5.00	50	2.50	492	3.75	738	5.00	984
5.50	55	2.75	541	4.13	812	5.50	1082
6.00	60	3.00	590	4.50	886	6.00	1181
6.50	65	3.25	640	4.88	959	6.50	1279
7.00	70	3.50	689	5.25	1033	7.00	1378
7.50	75	3.75	738	5.63	1107	7.50	1476
8.00	80	4.00	787	6.00	1181	8.00	1574
8.50	85	4.25	836	6.38	1255	8.50	1673
9.00	90	4.50	886	6.75	1328	9.00	1771
9.50	95	4.75	935	7.13	1402	9.50	1870
10.00	100	5.00	984	7.50	1476	10.00	1968

5. Low Ambient Fan Control

5.1. High Efficiency A Box Fan Operation

The outdoor fan in a high efficiency A Box unit operates at three distinct speeds; High, Low and Extra-low. At higher outdoor temperatures, (above 65F), the fan operates at high speed for a high cooling demand and at low speed for a low cooling or de-humidification demand. At low outdoor temperatures the fan is off until the liquid pressure switch, S11 closes. Then the fan runs at extra-low speed.

5.2. Low Ambient Fan Cycling - Other Units

During low ambient conditions, various outdoor fans are cycled by liquid line pressure switches; S11, S84, S85 and S94. The M2 unit controller will also de-energize fans due to low outdoor temperature. See Figure 4, for fan layouts and tables 9 through 14 for low ambient fan operations.

BOX Size	Fan Layout	Models	Compr.	Fans
A BOX		LCH, LGH 36H,48H,60H	1 (2 step)	1 (variable)
		LCH, LGH 36S,48S,60S,72H	1	1
B BOX		LCH, LGH 090,102,120,150	2	2
C1 BOX		LCH, LGH 156	3	3 (2 outputs)
C2 BOX		LCH, LGH 180	3	4
C3 BOX		LCH, LGH 210	3	6
		LCH, LGH 240/300S	4	6
E BOX		LCH, LGH 420,480,540,600	4	6

Figure 4. Number of Compressors/Fans and Fan Layout

Table 9 .LCH, LGH 36S,48S,60S,72H Low Ambient Fan Operations

Models	Fan	Associated Compressor	Fan Control
LCH, LGH 36S,48S,60S,72H	1	1	On with S11

Table 10. LCH, LGH 090,102,120,150 Low Ambient Fan Operations

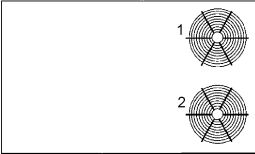
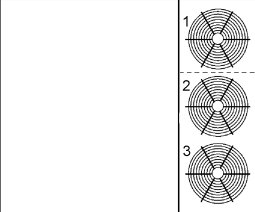
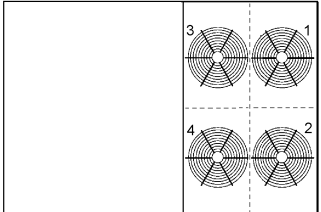
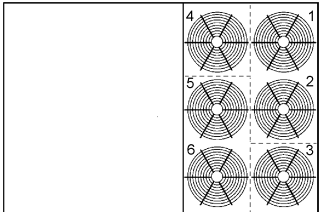
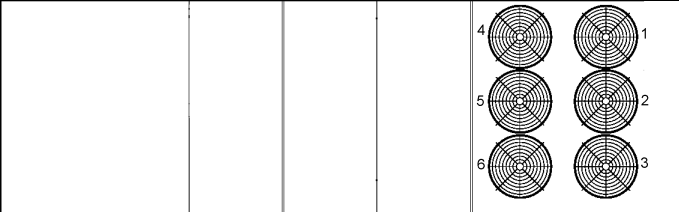
Models	Fan	Associated Compressor	Low Ambient Control OD Temp < ECTO 4.07 (55F)
LCH, LGH 090,102,120,150	1	1	OFF
	2	.2	On with S11 or S84

Table 11. LCH, LGH 156 Low Ambient Fan Operations

Models	Fan	Associated Compressor	Low Ambient Control OD Temp < ECTO 4.07 (55F)
LCH, LGH 156	1	1, 2, 3	On with S11 or S84 or S85
	2, 3	1, 2, 3	OFF

Table 12. LCH, LGH 180 Low Ambient Fan Operations

Models	Fan	Associated Compressor	Low Ambient Control OD Temp < ECTO 4.07 (55F)
LCH, LGH 180	1	1, 3	On with S11, S84 or S85
	2	1, 3	OFF
	3	2, 3	On with S84 or S85
	4	2, 3	OFF

Table 13. LCH, LGH 210 Low Ambient Fan Operations

Models	Fan	Associated Compressor	Low Ambient Control OD Temp < ECTO 4.07 (55F) and > ECTO 4.06 (40F)	Low Ambient Control OD Temp < ECTO 4.06 (40F)
LCH, LGH 210	1	1, 3	On with CP1	OFF
	2	1, 3	OFF	OFF
	3	1, 3	On with S11, S84 or S85	On with S11, S84 or S85
	4	2, 3	On with S84 or S85	On with S84 or S85
	5	2, 3	OFF	OFF
	6	2, 3	On with S84 or S85	OFF

Table 14. LCH, LGH 240/300S LCH, LGH 420,480,540,600 Low Ambient Fan Operations

Models	Fan	Associated Compressor	Low Ambient Control OD Temp < ECTO 4.07 (55F) and > ECTO 4.06 (40F)	Low Ambient Control OD Temp < ECTO 4.06 (40F)
LCH, LGH 240/300S LCH, LGH 420,480,540,600	1	1, 2	On with CP1 or CP2	OFF
	2	1, 2	OFF	OFF
	3	1, 2	On with S11 or S84	On with S11 or S84
	4	3, 4	On with S84 or S85	On with S84 or S85
	5	3, 4	OFF	OFF
	6	3, 4	On with CP3 or CP4	OFF

CP1 - compressor 1, S11 - liquid line pressure switch on circuit 1.
 CP2 - compressor 2, S84 - liquid line pressure switch on circuit 2.
 CP3 - compressor 3, S85 - liquid line pressure switch on circuit 3.
 CP4 - compressor 4, S94 - liquid line pressure switch on circuit 4.

6. Reheat Operation

6.1. Reheat Operation

Reheat is a combination of cooling to dehumidify and heating to maintain space temperature. Supermarket reheat uses gas heat and Humiditrol® units route hot gas to a reheat coil downstream of the evaporator. A gas heat unit is required for Supermarket Reheat and a Humiditrol® unit is required for Humiditrol Reheat. Economizer operation is disabled during reheat operation except for Supermarket Reheat operation ECTO 4.24 option 1.

6.2. Supermarket Reheat Operation

ECTO 4.24 Option 1 De-Humidistat Control

IMPORTANT - Supermarket Reheat is allowed on gas/electric units only; not electric/electric or heat pump units.

A de-humidistat will bring on first-stage cooling to dehumidify and a room thermostat will energize heating to maintain indoor temperature. To disable free cooling in this mode, select economizer global mode (figure 9) but do not connect the global input (P297-9).

An optional de-humidistat is required. Refer to figure 5.

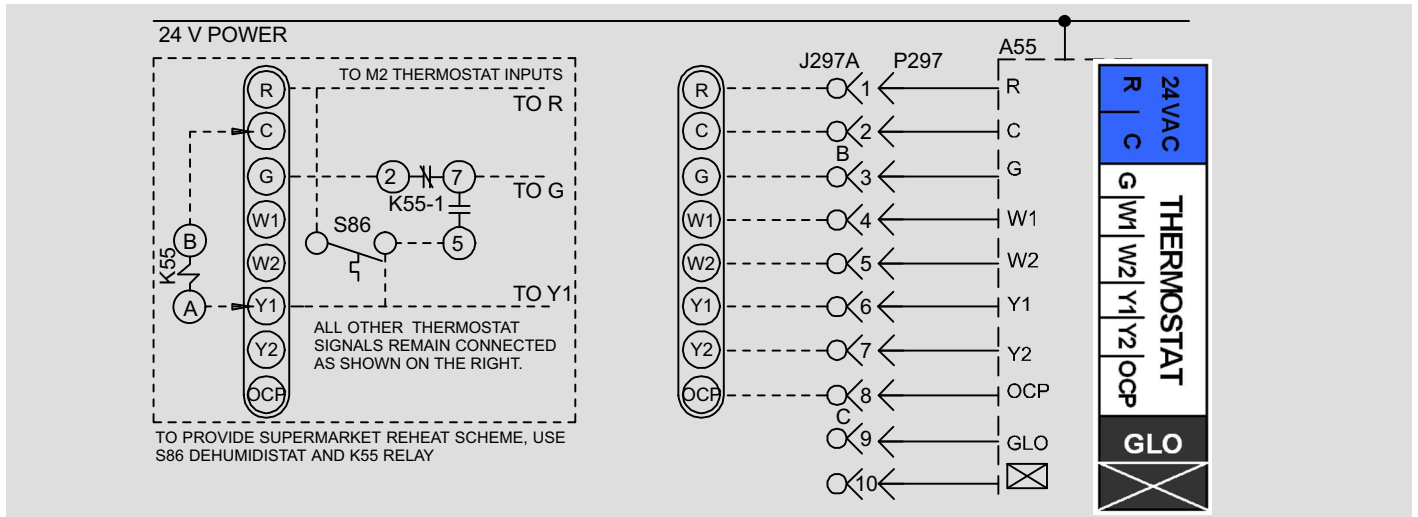

Figure 5. Supermarket Reheat Diagram (ECTO 4.24 Option 1)

ECTO 4.24 Option 2 RH Sensor Control

A relative humidity sensor will bring on first-stage cooling based on the set point set with ECTO 4.25 or from the L Connection network. First-stage cooling will de-energize when RH drops to ECTO 4.25 minus 4.26. A room thermostat or zone sensor will energize heating to maintain indoor temperature.

An optional RH sensor is required. Refer to figure 6.

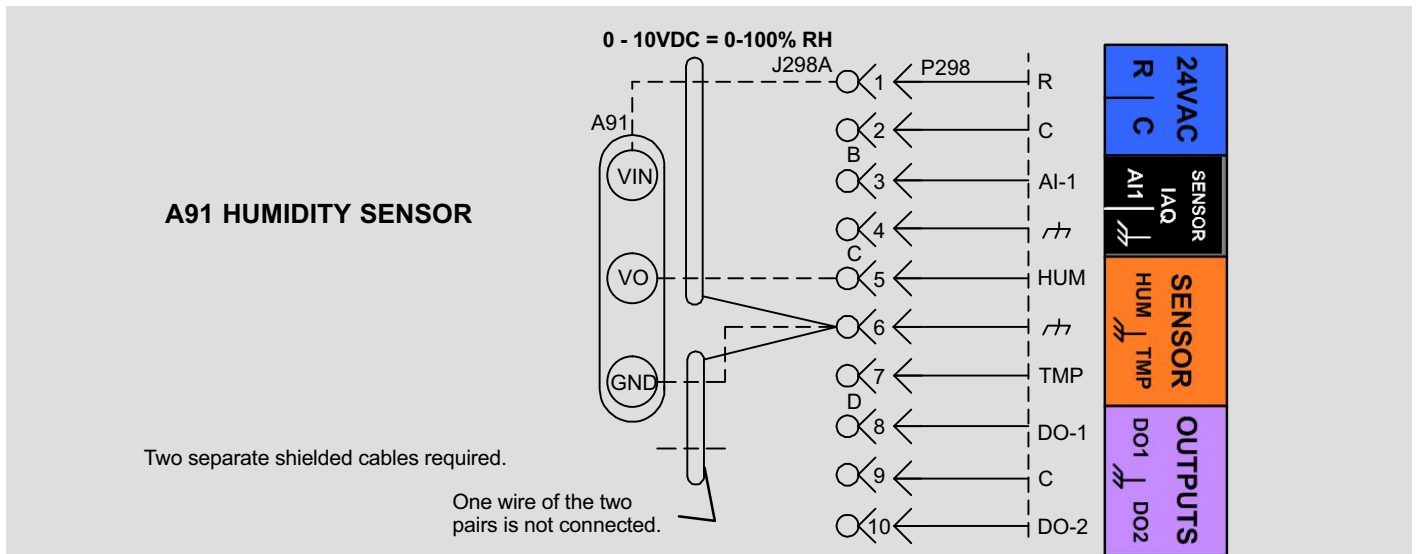

Figure 6. Reheat Sensor Diagram

6.3. Humiditrol Reheat Operation

A relative humidity sensor will energize first-stage compressor(s) and hot gas will be routed to the reheat coil based on the set point set with ECTO 4.25 or from the L Connection network. The following options show additional conditions which must be met before reheat will be energized:

ECTO 4.24 option 3

- Blower energized.
- Occupied time period.
- One previous cooling demand must have occurred.

ECTO 4.24 option 5

- One previous cooling demand must have occurred.

ECTO 4.24 option 6

- Blower energized.
- Occupied time period.

ECTO 4.24 option 7

- No additional conditions.

Humiditrol reheat will de-energize when the RH drops to ECTO 4.25 minus 4.26. An optional RH sensor is required. See figure 6. See tables 18 through 23 for reheat compressor staging. Shaded rows indicate reheat operation.

6.4. Humiditrol Reheat Operation - Digital

ECTO 4.25 Set to 100

Humiditrol reheat is controlled by the digital input A55_P269_9 (M2) only. The input signal will energize compressor(s) and reheat solenoid. Connect wiring to M2 as shown in figure 7. See tables 18 through 23 for reheat compressor staging.

6.5. RH Measurement / Display

ECTO 4.24 option 4—When an optional relative humidity sensor is installed, the % RH can be displayed on the M2 readout and over the L Connection network via the NCP and/or PC software. Option 4 is NOT used to control Humiditrol or Supermarket Reheat. Option 4 may be used for outside air dehumidification. Refer to figure 6.

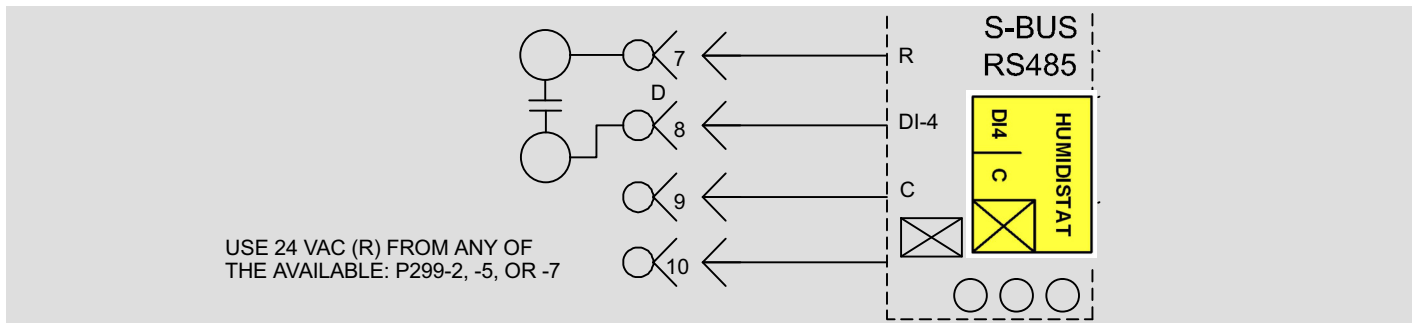

Figure 7. Humiditrol Reheat Diagram (ECTO 4.25 set to 100 for digital control)

6.6. Outside Air For Dehumidification

The M2 has an option that allows FAT heated outside air to be used to dehumidify when outside air temperature is low. When ECTO 4.24 is set to options 2-7, outside air will be used for dehumidification instead of the compressor. When the outside air temperature is less than set point, ECTO 7.04 must be set to 70°F or less to enable this option. Additional conditions for operation apply. See table 15.

The M2 will use the gas or electric heat to temper discharge air and the outside air will be used to dehumidify (when there is a dehumidification demand and outside air is cool). Adjust the following settings:

- ECTO 7.02 Outdoor Air Set point (50°F typical)
- ECTO 7.03 Damper Position (40% typical)
- ECTO 7.04 Fresh Air Heating Reheat Set point (65°F typical)

This option can be used with ECTO 4.24 options 2-7 only - not with option 1. Refer to table 17.

Table 15. Outside Air for Dehumidification Conditions

ECTO 4.24 Option	Outside Air Dehumidification Conditions
1	Not allowed.
2	Allowed. No conditions apply.
3	Allowed, blower must be energized and in occupied mode. No previous cooling demand is required.
4	Allowed. Must be occupied.
5	Allowed, blower must be energized and in occupied mode. No previous cooling demand is required.
6	Allowed. No conditions apply.
7	Allowed. No conditions apply.

Table 16. Summary Of Reheat ECTO Options

No.	Name	Min	Default	Max	Units	Description
4.24	Reheat_Control	0	0	7	Option	<p>Reheat Control Mode</p> <ul style="list-style-type: none"> 0- No reheat. 1- Supermarket reheat using De-Humidistat (Tstat mode only) 2- Supermarket reheat using RH sensor. 3- Humiditrol reheat. Conditions: Blower must be energized, Must be occupied, At least one previous cooling demand. 4- RH measurement / display. No Supermarket or Humiditrol reheat. 5- Humiditrol reheat. Conditions: At least one previous cooling demand. 6- Humiditrol reheat. Conditions: Blower must be energized, Must be occupied. 7- Humiditrol reheat. Conditions: None
4.25	Reheat_SP	0 0	60 60	100 100	Counts P:%RH	<p>Percent relative humidity where supermarket or Humiditrol reheat demand is energized. Used of Reheat option 2,3,5,6,or 7. Reheat is de-energized at set point – dead-band (ECTO 4.26).</p> <p>If value = 100, Humiditrol reheat is controlled by the digital input A55_P269_9 (M2) only. Energized input signal calls for reheat demand.</p> <p>L Connection Network RH set point will override this set point. (Such as from NCP).</p> 
4.26	Reheat_RH_DB	1 1	3 3	10 10	Counts P:%RH	<p>Reheat RH dead-band.</p> <p>Used of Reheat option 2,3,5,6,or 7. Reheat is on when RH>=ECTO 4.25 and off when RH< ECTO 4.25 – ECTO 4.26.</p>

Table 17. Outside Air for Dehumidification Parameters

No.	Name	Min	Default	Max	Units	Description
7.02	Reheat_FAH_OAT_SP	113 60	136 45	175 20	Counts Y:DegF	Outdoor air temperature set point that enables fresh air heating for reheat demand and opens damper to ECTO 7.03 when outdoor air is less than set point.
7.03	Reheat_FAH_%_Damper	5 5	40 40	100 100	Counts P:%	Fresh air damper position during Fresh Air Heating reheat operation.
7.04	Reheat_FAH_SP	139 70	138 Disabled	183 40	Counts X:De-gF	Fresh Air Heating Reheat set point. Minimum value of 138 disables FAH-Reheat.

Table 18. 1-Compressor Humiditrol Default Operation (using 2-stage Thermostat or Zone Sensor)

Demands						Unit Operation	
T'Stat or Zone Sensor	Economizer	Dehumidification	Free Cooling On	CP1 On	Reheat Valve 1 On	Summary	
						Idle.	
		X		X	X	CP1 Reheat (Reheat Stage 1)	
	X	X		X	X	CP1 Reheat (Reheat Stage 1)	
1st				X		CP1 Cool	
1st	X		X			Free Cool	
1st		X		X		CP1 Cool	
1st	X	X		X		CP1 Cool	
2nd				X		CP1 Cool	
2nd	X		X	X		Free Cool, CP1 Cool	
2nd		X		X		CP1 Cool	
2nd	X	X		X		CP1 Cool	

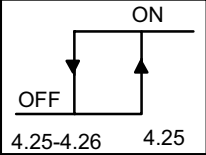
Free cooling operation is only available on units equipped with an economizer. Default dehumidification demand = RH (A91) > 60% (RH set point ECTO 4.25). Optional dehumidification demand = P299-8 energized if ECTO 4.25 is set to 100 (digital demand). Heating demand overrides reheat.

Table 19. 2-Compressor Humiditrol Default Operation (using 2-stage Thermostat or Zone Sensor)

Demands							Unit Operation	
T'Stat	Zone Sensor	Economizer	Dehumidification	Free Cooling On	CP1 On	CP2 On	Summary	
							Idle.	
			X		X	X	CP1 Reheat (Reheat Stage 1)	
		X	X		X	X	CP1 Reheat (Reheat Stage 1)	
1st	1st				X		CP1 Cool	
1st	1st	X		X	X		Free Cool	
1st	1st		X		X	X	CP1 Reheat, CP2 Cool (Reheat Stage 2)	
1st	1st	X	X		X	X	CP1 Reheat, CP2 Cool (Reheat Stage 2)	
2nd	2nd				X	X	CP1 Cool, CP2 Cool	
2nd	2nd	X		X	X		Free Cool, CP1 Cool	
2nd	2nd		X		X	X	CP1 Cool, CP2 Cool	
2nd	2nd	X	X		X	X	CP1 Cool, CP2 Cool	
N/A	3rd				X	X	CP1 Cool, CP2 Cool	
N/A	3rd	X		X	X	X	Free Cool, CP1 Cool, CP2 Cool	
N/A	3rd		X		X	X	CP1 Cool, CP2 Cool	
N/A	3rd	X	X		X	X	CP1 Cool, CP2 Cool	

Free cooling operation is only available on units equipped with an economizer. Default dehumidification demand = RH (A91) > 60% (RH set point ECTO 4.25). Optional dehumidification demand = P299-8 energized if ECTO 4.25 is set to 100 (digital demand). Heating demand overrides reheat.

Table 20. 3-Compressor Humiditrol Default Operation (using 2-stage Thermostat or Zone Sensor)

Demands			Unit Operation						Summary
T'Stat	Economizer	Dehumidification	Free Cooling On	CP1 On	CP2 On	CP3 On	Reheat Valve 1 On	Reheat Valve 2 On	
									Idle.
		X		X	X		X	X	CP1 Reheat, CP2 Reheat (Reheat Stage 1)
	X	X		X	X		X	X	CP1 Reheat, CP2 Reheat (Reheat Stage 1)
1st				X	x				CP1 Cool, CP2 Cool
1st	X		X						Free Cool
1st		X		X	X	X	X	X	CP1 Reheat, CP2 Reheat, CP3 Cool (Reheat Stage 2)
1st	X	X		X	X	X	X	X	CP1 Reheat, CP2 Reheat, CP3 Cool (Reheat Stage 2)
2nd				X	X	X			CP1 Cool, CP2 Cool, CP3 Cool
2nd	X		X	X	X				Free Cool, CP1 Cool, CP2 Cool
2nd		X		X	X	X			CP1 Cool, CP2 Cool, CP3 Cool
2nd	X	X		X	X	X			CP1 Cool, CP2 Cool, CP3 Cool

Free cooling operation is only available on units equipped with an economizer. Default dehumidification demand = RH (A91) > 60% (RH set point ECTO 4.25). Optional dehumidification demand = P299-8 energized if ECTO 4.25 is set to 100 (digital demand). Heating demand overrides reheat.

Table 21. 3-Compressor Humiditrol Default Operation (using 4-stage Thermostat DDC with Zone Sensor)

Demands			Unit Operation						Summary
T'Stat DDC, or Zone Sensor	Economizer	Dehumidification	Free Cooling On	CP1 On	CP2 On	CP3 On	Reheat Valve 1 On	Reheat Valve 2 On	
									Idle.
		X		X	X		X	X	CP1 Reheat, CP2 Reheat (Reheat Stage 1)
	X	X		X	X		X	X	CP1 Reheat, CP2 Reheat (Reheat Stage 1)
1st				X	X				CP1 Cool
1st	X		X						Free Cool
1st		X		X	X	X	X	X	CP1 Reheat, CP2 Reheat, CP3 Cool (Reheat Stage 2)
1st	X	X		X	X	X	X	X	CP1 Reheat, CP2 Reheat, CP3 Cool (Reheat Stage 2)
2nd				X	X	X			CP1 Cool, CP2 Cool
2nd	X		X	X					Free Cool, CP1 Cool
2nd		X		X	X				CP1 Cool, CP2 Cool
2nd	X	X		X	X				CP1 Cool, CP2 Cool
3rd				X	X	X			CP1 Cool, CP2 Cool, CP3 Cool
3rd	X		X	X	X				Free Cool, CP1 Cool, CP2 Cool
3rd		X		X	X	X			CP1 Cool, CP2 Cool, CP3 Cool
3rd	X	X		X	X	X			CP1 Cool, CP2 Cool, CP3 Cool
4th				X	X	X			CP1 Cool, CP2 Cool, CP3 Cool
4th	X		X	X	X	X			Free Cool, CP1 Cool, CP2 Cool, CP3 Cool
4th		X		X	X	X			CP1 Cool, CP2 Cool, CP3 Cool
4th	X	X		X	X	X			CP1 Cool, CP2 Cool, CP3 Cool

Free cooling operation is only available on units equipped with an economizer. Default dehumidification demand = RH (A91) > 60% (RH set point ECTO 4.25). Optional dehumidification demand = P299-8 energized if ECTO 4.25 is set to 100 (digital demand). Heating demand overrides reheat.

Table 22. 4-Compressor Humiditrol Default Operation (using 2-stage Thermostat)

Demands			Unit Operation							
T'Stat	Economizer	Dehumidification	Free Cooling On	CP1 On	CP2 On	CP3 On	CP4 On	Reheat Valve 1 On	Reheat Valve 2 On	Summary
										Idle.
		X		X	X			X	X	CP1 Reheat, CP2 Reheat (Reheat Stage 1)
	X	X		X	X			X	X	CP1 Reheat, CP2 Reheat (Reheat Stage 1)
1st				X	X					CP1 Cool, CP2 Cool
1st	X		X							Free Cool
1st		X		X	X	X	X	X	X	CP1 Reheat, CP2 Reheat, CP3 Cool, CP4 Cool (Reheat Stage 2)
1st	X	X		X	X	X	X	X	X	CP1 Reheat, CP2 Reheat, CP3 Cool, CP4 Cool (Reheat Stage 2)
2nd				X	X	X	X			CP1 Cool, CP2 Cool, CP3 Cool, CP4 Cool
2nd	X		X	X	X					Free Cool, CP1 Cool, CP2 Cool
2nd		X		X	X	X	X			CP1 Cool, CP2 Cool, CP3 Cool, CP4 Cool
2nd	X	X		X	X	X	X			CP1 Cool, CP2 Cool, CP3 Cool, CP4 Cool

Free cooling operation is only available on units equipped with an economizer. Default dehumidification demand = RH (A91) > 60% (RH set point EC-TO 4.25). Optional dehumidification demand = P299-8 energized if ECTO 4.25 is set to 100 (digital demand). Heating demand overrides reheat.

Table 23. 4-Compressor Humiditrol Default Operation (using 4-stage Thermostat DDC with Zone Sensor)

Demands			Unit Operation							
T'Stat, DDC, or Zone Sensor	Economizer	Dehumidification	Free Cooling On	CP1 On	CP2 On	CP3 On	CP4 On	Reheat Valve 1 On	Reheat Valve 2 On	Summary
										Idle.
		X		X	X			X	X	CP1 Reheat, CP2 Reheat (Reheat Stage 1)
	X	X		X	X			X	X	CP1 Reheat, CP2 Reheat (Reheat Stage 1)
1st				X						CP1 Cool
1st	X		X							Free Cool
1st		X		X	X	X		X	X	CP1 Reheat, CP2 Reheat, CP3 Cool (Reheat Stage 2)
1st	X	X		X	X	X		X	X	CP1 Reheat, CP2 Reheat, CP3 Cool (Reheat Stage 2)
2nd				X	X					CP1 Cool, CP2 Cool
2nd	X		X	X						Free Cool, CP1 Cool
2nd		X		X	X	X	X	X	X	CP1 Reheat, CP2 Reheat, CP3 Cool, CP4 Cool (Reheat Stage 3)
2nd	X	X		X	X	X	X	X	X	CP1 Reheat, CP2 Reheat, CP3 Cool, CP4 Cool (Reheat Stage 3)
3rd				X	X	X				CP1 Cool, CP2 Cool, CP3 Cool
3rd	X		X	X	X					Free Cool, CP1 Cool, CP2 Cool
3rd		X		X	X	X				CP1 Cool, CP2 Cool, CP3 Cool
3rd	X	X		X	X	X				CP1 Cool, CP2 Cool, CP3 Cool
4th				X	X	X	X			CP1 Cool, CP2 Cool, CP3 Cool, CP4 Cool
4th	X		X	X	X	X	X			Free Cool, CP1 Cool, CP2 Cool, CP3 Cool, CP4 Cool
4th		X		X	X	X	X			CP1 Cool, CP2 Cool, CP3 Cool, CP4 Cool
4th	X	X		X	X	X	X			CP1 Cool, CP2 Cool, CP3 Cool, CP4 Cool

Free cooling operation is only available on units equipped with an economizer. Default dehumidification demand = RH (A91) > 60% (RH set point EC-TO 4.25). Optional dehumidification demand = P299-8 energized if ECTO 4.25 is set to 100 (digital demand).

7. Economizer

7.1. General

The economizer, when configured, controls

- damper position, which determines how much outdoor air is used to meet free cooling or indoor air quality (IAQ) requirements, and
- the optional power exhaust fans.

On a cooling demand, outdoor air is used for free cooling instead of first-stage compressor(s) when outdoor air is suitable (OAS).

7.2. Outdoor Air Suitable (OAS) LED

A yellow LED which is labeled OAS provides economizer status. A steady yellow LED indicates that outdoor air is suitable for free cooling. A flashing yellow OAS light indicates the IAQ sensor requires outdoor air. (A flashing yellow LED can also mean that the economizer dampers are open to bring in fresh air while a compressor is on.) If the economizer is already operating, a flashing yellow OAS light indicates the IAQ sensor requires more outdoor air than is suitable for free cooling (see figure 8).

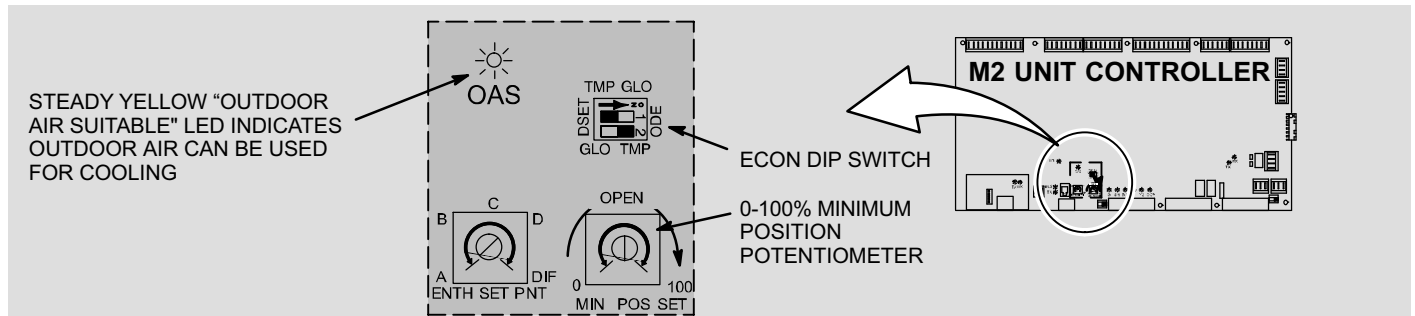

Figure 8. Economizer controls

7.3. DIP Switch Settings

The DIP switch setting determines the mode used to enable free cooling. The DIP switch also has a mode to set the damper minimum position and test damper operation. DIP switch is factory-set when the economizer is factory-configured.

7.4. Free Cooling Discharge Air Set point

When outdoor air conditions are suitable and economizer is set to provide free cooling, dampers will modulate to achieve a discharge air temperature of 55°F (13°C) default. This set point is adjustable between 45° and 65°F.

The set point can also be automatically increased when outdoor or return air temperatures drop. See Outdoor Air Reset and Return Air Reset in the Discharge Air Control section. The unit does not have to be operating in discharge air cooling mode to adjust the set point, or to use set point reset.

The operating profile of the economizer damper, during free cooling when any compressors are on, can be selected as follows:

- damper opens to its maximum position when any compressors start.
- damper continues to modulate while compressors are on, but the effect of mechanical cooling will force the damper closed to its minimum position.
- damper modulates to its maximum position where it remains for at least 3 minutes. If the damper has been continuously in this position for at least three minutes, then a second stage cooling demand will be allowed to turn on the first stage of mechanical cooling. While the mechanical cooling is on, the damper is held to its maximum position, and does not modulate until the second stage demand is satisfied.

7.5. Free Cooling Compressor Lockout Set point

When the outdoor air temperature falls below the free-cooling set point, and outdoor air is suitable, then mechanical cooling is kept off, or is turned off if it is on.

7.6. Outdoor Air Suitability

There are six options available to determine outdoor air suitability (OAS) for free cooling. See table 24. Economizer settings are shown for each mode in figure 9.

The appropriate sensors are provided when the economizer is factory-configured. When the economizer is field-configured, the ODE mode requires additional field-provided sensor(s). See table 24. The TEMP mode uses sensors provided with all units.

Table 24. Free Cooling Options

Free cooling mode	DIP SW positions	MODE Selection	CONTROL Selection	OAS set point calc if CONTROL is SENSIBLE
Temperature offset	1,2 to TMP	TEMP	OFFSET	OAT<RAT-OFFSET (0 to 40 F)
Temperature set point	1,2 to TMP	TEMP	OAT STPT	OAT<OAT STPT (41 to 70 F)
Remote	1,2 to TMP	TEMP	ANY	OAS sent by network.
Enthalpy differential (Potentiometer set to DIFF)	1,2 to ODE	ENTH	N/A	ODE<IDE
Enthalpy set point (Potentiometer set to A-D)	1,2 to ODE	ENTH	N/A	ODE<POT
Global input	1,2 to GLO	GLOBAL	N/A	GLO input

Note-All economizer modes of operation, except DSET, will modulate dampers to 55°F (13°C) discharge air.

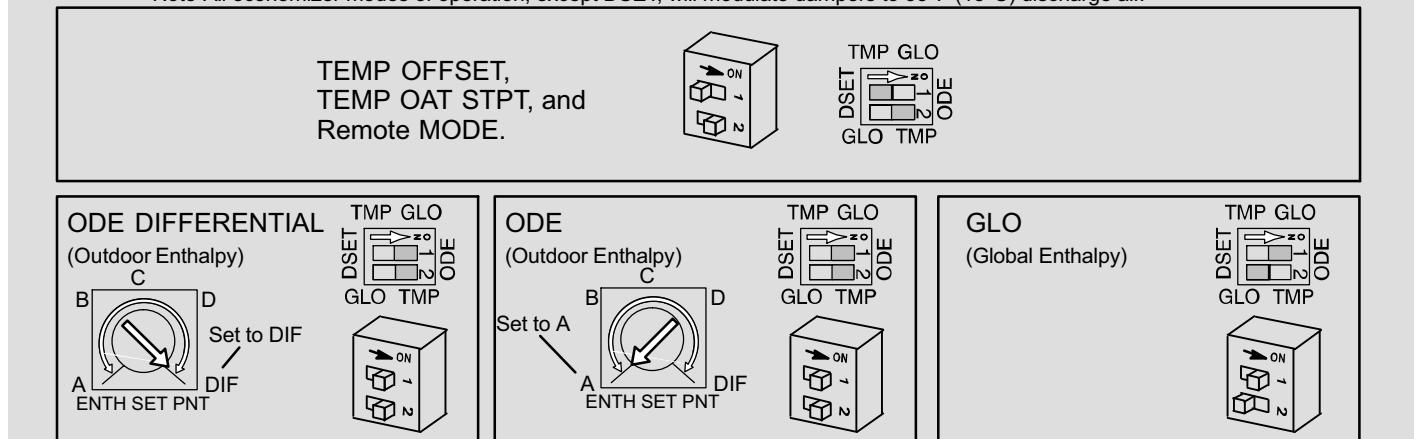

Figure 9. Economizer free cooling settings

7.7. Enthalpy Set point

This setting pertains to the ODE free cooling mode only. The M2 will enable free cooling when outdoor air enthalpy (A7) is less than the enthalpy set point. Table 25 shows the approximate enthalpy set points for each potentiometer setting at 50% relative humidity.

Table 25. Enthalpy Control Set Points

The recommended enthalpy set point is "A". If the economizer is allowing air which is too warm or too humid to enter the system, the enthalpy control may be changed to a lower setting (B, C, or D).	Control Setting	Enthalpy Control Set point At 50% Relative Humidity Approximate Degrees F (C)
	A	73 (23)
	B	70 (21)
	C	67 (19)
	D	63 (17)

Example:—At setting "A", the enthalpy control will modulate dampers open when outdoor air is at 73°F and 50% relative humidity. If space temperatures are too warm, rotate the potentiometer to "B". The enthalpy control will now modulate dampers open when outdoor air is 70°F and 50% relative humidity.

7.8. Damper Minimum Position Potentiometer

Set economizer DIP switch to "DSET" position as shown in figure 10. DSET is a manual mode that locks the economizer into minimum position. Rotate MIN POS SET potentiometer to the approximate desired damper position.

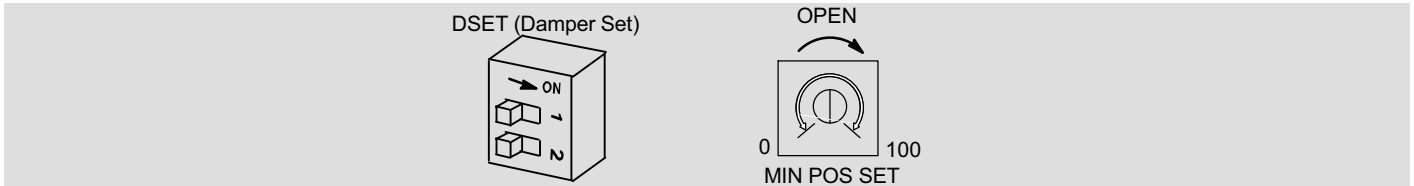

Figure 10. Manual Damper Set DIP Switch

Check indicator on damper motor to determine actual damper position. Adjust potentiometer until damper motor reads desired position. See figure 11. Damper minimum position can also be set using ECTO 5.24. This will disable the potentiometer.

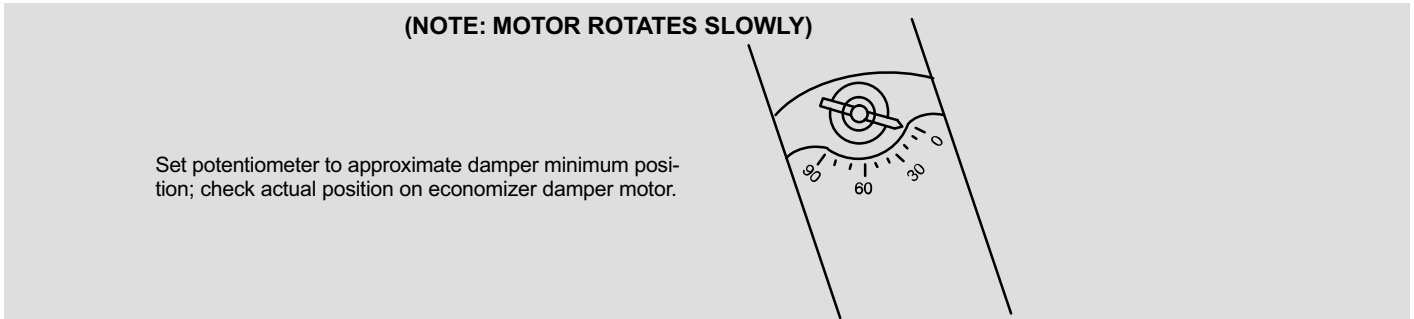

Figure 11. Economizer Damper Min. Position

7.9. Damper Maximum Position

Economizer dampers open to 100% at the default setting. Adjust ECTO parameter 5.23 to reduce the maximum damper opening for free cooling.

7.10. Motorized Outdoor Air Damper

Set damper position according to "Damper Minimum Position Potentiometer" section. For normal operation, make sure the economizer DIP switch is set to "GLO" position as shown in figure 9. The damper will open to the specified position during the occupied time period and close during the unoccupied time period.

7.11. Economizer Checkout

The following checkout procedures are completed with unit energized. Confirm proper operation of the heartbeat LED. Step 1 will determine whether the economizer is allowing full damper travel. Use step 2 when the damper does not respond to step 1.

Steps 3, 4, 5, and 6 checkout the operating modes; checkout only the mode that applies to the unit being worked on. Use "DSET" Operation checkout only when step 1 refers to it.

CAUTION - Power exhaust fans will be functional. To prevent operation of gravity exhaust fans, disconnect power to unit and then PED jack/plug P/J18.

Step 1. Economizer Output Voltage

- A** Set the DIP switch to DSET.
- B** Adjust the MIN POS SET potentiometer to the 0% position (fully counterclockwise). The motor will slowly modulate to the closed position.
- C** Adjust the MIN POS SET potentiometer to the 100% position (fully clockwise). The motor will slowly modulate to the fully opened position.
- D** If the motor does not respond, go to step 2. If the motor does respond properly, go to the appropriate mode of operation checkout.

Step 2. "DSET" OPERATION

- A** Set the DIP switch to the "DSET" position.
- B** Adjust the MIN POS SET potentiometer to the 0% position (fully counterclockwise).
- C** Measure the voltage on P262 between pin 3 (VOT damper control) and pin 2 (GND) **using pin 1 as common**. Voltage should read approximately 2 VDC.
- D** Adjust the MIN POS SET potentiometer to the 100% position (fully clockwise).

NOTE - Allow approximately 30 seconds for voltage to react.

- E Measure the voltage between P262 between pin 3 (VOT damper control) and pin 2 (GND) **using pin 1 as common**. Voltage should read approximately **10 volts DC**.

Step 3. "ODE" Mode of Operation

In the ODE mode, dampers open for free cooling when the outdoor enthalpy is less than the enthalpy set point; dampers will modulate discharge air temperature (RT6) to 55°F (13°C).

- A Set the DIP switch to ODE mode.
- B To simulate low outdoor enthalpy, set the enthalpy set point to "B." Disconnect A7 outdoor enthalpy sensor jack/plugs J/P104. Connect a 200 ohm resistor across plug J104-1 and J104-2. J104 is located in the filter access area.
- C After a few seconds delay, the yellow OAS LED (see figure 8) should turn on.
- D If the OAS LED does not turn on, check all connections and wiring between J104 and the control.

Step 4. "ODE Differential" Mode of Operation

In the DIF mode, dampers open for free cooling when the outdoor air enthalpy is lower than the return air enthalpy; dampers will modulate discharge air temperature (RT6) to 55°F (13°C).

- A Set the DIP switch to ODE.
- B Set the enthalpy set point potentiometer to DIF.
- C Use two resistors to simulate outdoor air enthalpy suitable.
 - Disconnect A62 return air enthalpy sensor jack/plug J/P105. Place a 750 ohm resistor between J105-1 and J105-3. J/P105 is located in the filter access area.
 - Disconnect A7 outdoor enthalpy sensor jack/plugs J/P104. Connect a 100 ohm resistor across J104-1 and J104-2.
- D After a few seconds delay, the yellow OAS LED will turn on.

Step 5. All "TMP" Modes of Operation

In the TMP modes, the damper opens for free cooling when the outdoor air temperature is:

- Less than return air temperature (TMP DIFFERENTIAL)
- ECTO 6.26 less than return air temperature (TMP OFFSET)
- Less than ECTO 6.26 (TMP)

In all modes, dampers will modulate discharge air temperature (RT6) to 55°F (13°C).

Refer to the "Displaying Sensor Inputs" section to read return air (RT16) and outdoor air (RT17) temperatures. If outdoor air is not cooler than return air, simulate a colder outdoor air temperature with a resistor. Select a resistor value that corresponds to a temperature (see table 26):

- Less than return air temperature (TMP DIFFERENTIAL)
- ECTO 6.26 less than return air temperature (TMP OFFSET)
- Less than ECTO 6.26 (TMP)

Table 26. TMP Mode Resistor Values

Temp. °F (°C)	Size Resistor	Temp. °F (°C)	Size Resistor	Temp. °F (°C)	Size Resistor	Temp. °F (°C)	Size Resistor
30 (-1)	34,566	50 (10)	19,904	70 (21)	11,884	90 (32)	7,332
40 (4)	26,106	60 (16)	15,313	80 (27)	9,298	100 (38)	5,826

- A RT17 is located on the right wall of the control/compressor section on non-heat pump units. RT17 is located on the right front corner mullion of heat pump units. Disconnect 1/4" quick connect terminals on wires leading from sensor.
- B Jumper RT17 wires leading back to control with the appropriate resistor.
- C After a few seconds delay, the yellow OAS LED should turn on.
- D If the OAS LED does not turn on, check all connections and wiring between RT17 and the M2 board, and between RT16 and the M2 board.

Step 6. GLO Modulating Mode of Operation

In the GLO (modulating) mode, dampers modulate open for free cooling when the global input is energized; dampers will modulate discharge air temperature (RT6) to 55°F (13°C).

NOTE - The global input turns on the blower.

- A Set the DIP switch to GLO.
- B Connect a jumper between A55_P297-1 (24vac) and A55_P297-9 (global). The blower will be energized and the damper will slowly open if discharge air temperature (RT6) is greater than 55°F (13°C).
- C Disconnect 24vac to A55_P297-9. The blower will turn off and the damper will close.
- D If the damper does not actuate check all connections and wiring between P262A and B.

Step 7. Enthalpy Sensor Operation (A7 and A62)

A Connect a DC ammeter as shown in figure 12 to measure current of A7 or A62.

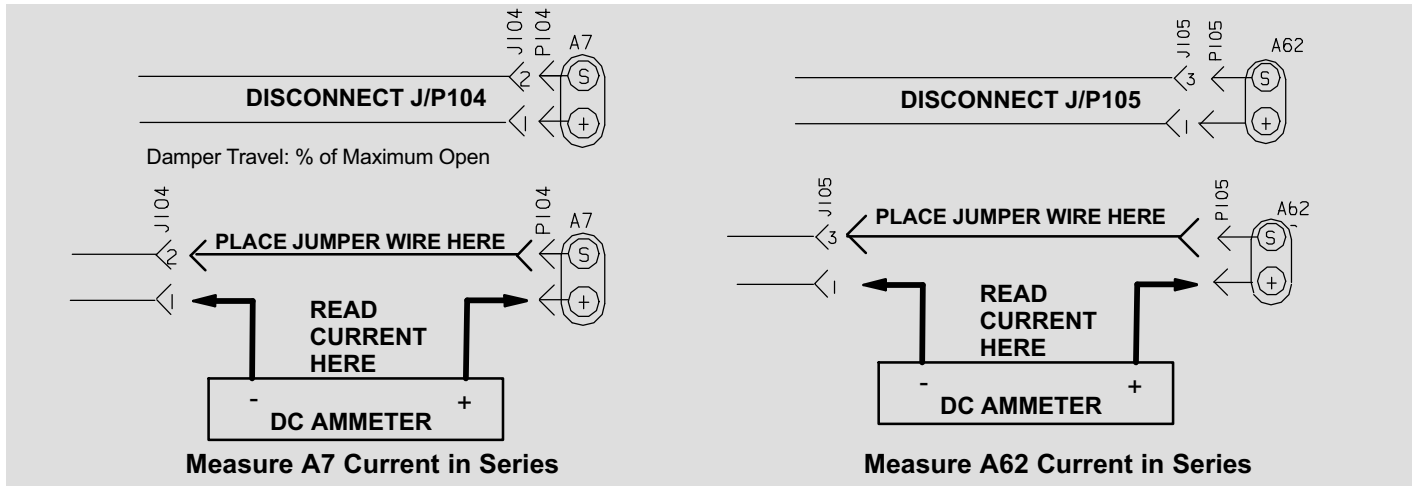

Figure 12. Measure A7 and A62 Current in Series

B The reading will be between 4 and 20 ma. depending on outdoor temperature and humidity. Refer to figure 13 to approximate reading.

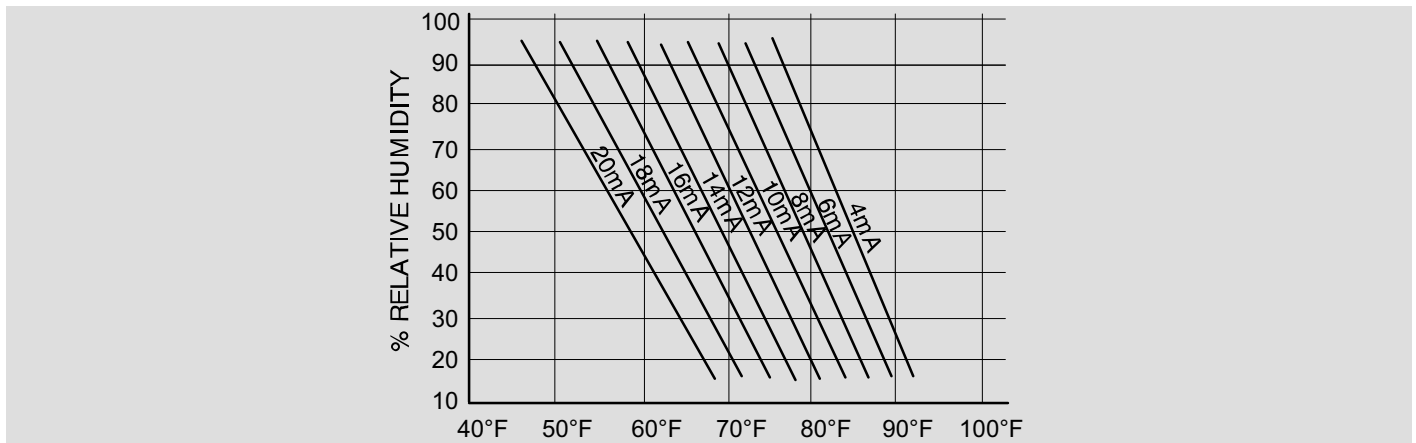

Figure 13. Enthalpy Sensor Output Current Honeywell C7400

C If the meter reads zero, check sensor wiring harness for continuity and/or check polarity of sensor wiring.

7.12. Demand Control Ventilation

7.12.1. General

A field-provided and installed indoor air quality sensor can be used with the modulating economizer to control CO₂ levels in the conditioned space. The CO₂ level in a space is an indicator of the number of people occupying a room. As the CO₂ level rises (indicating the occupancy of a room has increased), economizer dampers modulate open - regardless of outdoor air enthalpy. Likewise, as the CO₂ level falls (indicating the occupancy has decreased), economizer dampers modulate further closed.

Standard economizer installations have a minimum fresh air ventilation requirement based on maximum room occupancy. With standard economizer use, the amount of air required for maximum room occupancy is heated or cooled with each heating or cooling cycle. IAQ economizer installations use the maximum amount of required ventilation air only with maximum room occupancy; less outdoor air needs to be heated or cooled when fewer people are in the conditioned space.

If the economizer is operating in the free cooling mode and the IAQ control requires the damper to open further, the IAQ demand will override the free cooling demand. A flashing OAS LED (see figure 8) indicates an IAQ override condition.

The IAQ function is not energized during the unoccupied or night time period.

NOTE - The IAQ sensor may also be used with systems containing a motorized outdoor air damper.

7.12.2. Default Operation

The M2 has a 0-10VDC IAQ input for a standard 0-2000ppm CO₂ sensor. The economizer starts opening at a CO₂ level of 500 ppm ("start open" set point) and reaches full open at a CO₂ level of 1000ppm ("full open" set point). The damper opens to 100%. Determine damper travel position using the following formula.

$$\% \text{ Damper Travel} = \frac{\text{CO}_2\text{ppm} - \text{Start Open ppm}}{5}$$

Example: At a CO₂ level of 750ppm, the damper will be approximately 50% open:

$$\% \text{ Damper Travel} = \frac{750-500}{5} = 50\%$$

Use "Displaying Sensor Inputs" section to read CO₂ ppm. Figure 14 shows default or proportional operation.

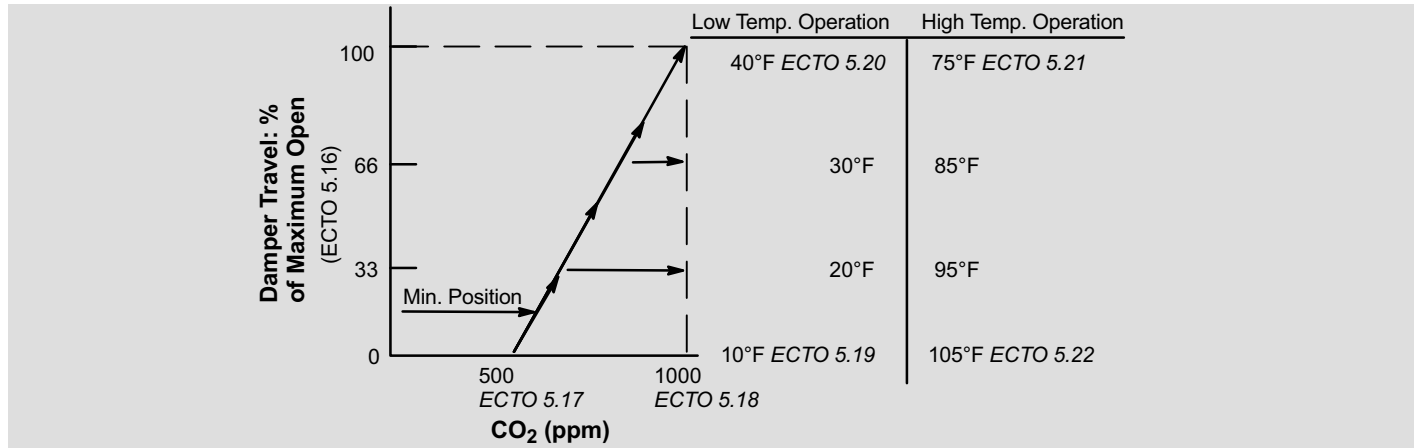

Figure 14. Default DCV Operation

7.12.3. ECTO Adjustments

Default IAQ economizer operation is based on common or average applications. Adjustments may be made to the IAQ ECTO parameters to alter operation or meet required specifications. Use the "ECTO Control Parameters" section to change ECTO parameters 5.16 through 5.22.

Select a DCV or OAC mode with ECTO 5.26. Modes 4 and 5 will bring on the unit blower when DCV calls for maximum damper open, and returns to auto-blower when DCV damper returns to 0. The other modes only operate when the unit blower is on, but will not bring it on themselves.

Some applications require a different CO₂ set point range than default settings. Damper "start open" (ECTO 5.17) and "full open" (ECTO 5.18) CO₂ set points may be adjusted from 0 to 1992ppm. Use the following formula to determine damper travel.

NOTE - When changing CO₂ set point range, "start open" set point should be less than "full-open" set point.

$$\% \text{ Damper Travel} = \frac{\text{CO}_2\text{ppm} - \text{Start Open ppm}}{\text{Full Open} - \text{Start Open}} \times \text{MaxOpen (ECTO 5.16)}$$

Example: An application requires the dampers open at 800 CO₂ ppm and reach full open at 1200. If the CO₂ level in the space reads 1000 ppm, calculate the damper percent open as follows.

$$\% \text{ Damper Travel} = \frac{1000 - 800}{1200 - 800} \text{ or } \frac{200}{400} \text{ or } .5 = 0.5 \times 100 = 50\%$$

7.12.3.1. Set Point Control Option

Set point Control mode is commonly used in areas with high occupancy and frequent change out such as classrooms or conference rooms.

In applications requiring this on/off damper response to CO₂ levels, set the "start open" (ECTO 5.17) set point higher than the "full open" (ECTO 5.18) set point. The dampers will drive to fully-open position immediately. Figure 15 shows the set point control option.

Change ECTO 5.19 and 5.20 to set the minimum outdoor temperature limits. Change ECTO 5.21 and 5.22 to set the maximum temperature value.

IMPORTANT - Mixed air temperatures less than 45°F (7°C) on units with an aluminized heat exchanger or less than 30°F (-1°C) on stainless steel heat exchangers will void the manufacturer's warranty.

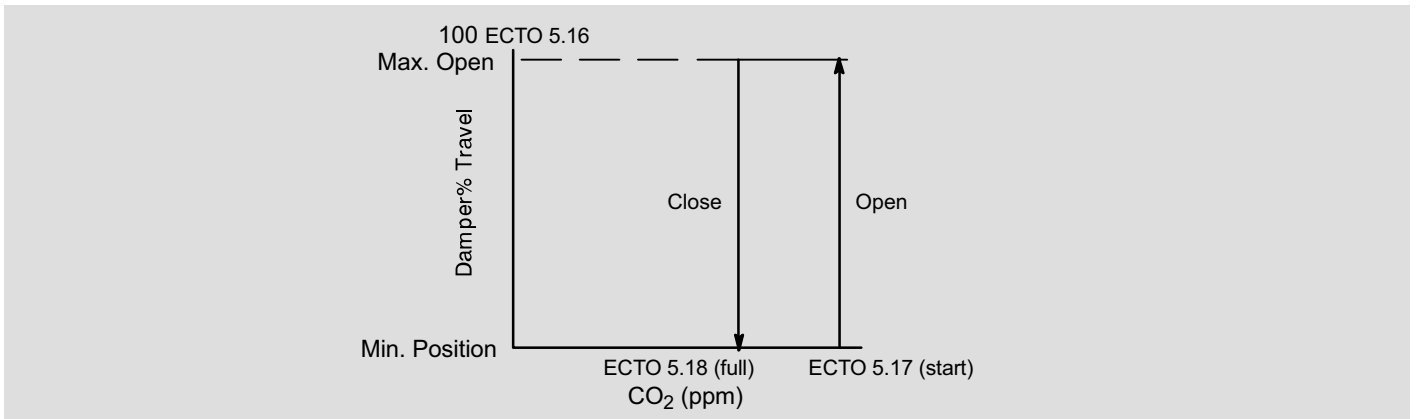

Figure 15. Set point Control IAQ Option

7.12.3.2. Determine IAQ Input

Check IAQ input (ppm) by using the "DATA/SENSORS" menu selection from the Prodigy display.

7.12.4. Outdoor Air Control Sensor (OAC)

An optional flow sensor (A24) may be used to control the amount of outdoor air brought into the space. If option 2 for ECTO 5.26 is selected, the M2 will modulate the outdoor air damper in order to hold a constant outdoor airflow. This option is very useful in VAV applications to maintain a constant outdoor airflow as the delivered air volume varies. A 0-10VDC flow meter located in the unit fresh air intake provides a signal to the general purpose board input A133_P194-6 (TB22-6). The M2 will modulate the damper based on ECTO 5.16 through 5.22 and ECTO 9.09-9.11 in order to maintain a constant air flow..

Unless the OAC kit instructs otherwise, use

- ECTO 5.17 = 0
- ECTO 5.18 = 255
- ECTO 5.26 = 2 (use 3 for no OAT limits)
- ECTO 9.01 = 5
- ECTO 9.09 = 2
- ECTO 9.10 = 30

Adjust ECTO 5.19 through 5.22 to modify Outdoor Air Flow operation based on the outdoor air temperature. Select ECTO 5.26 option 3 when this option is not desired.

In OAC mode, the M2 closes the damper as voltage increases to maintain a constant amount of fresh air. The sensor will read 10VDC at maximum flow and 0VDC at minimum flow.

7.12.4.1. Field Wiring

When outdoor air control sensor is field-installed, connect as shown in figure 16.

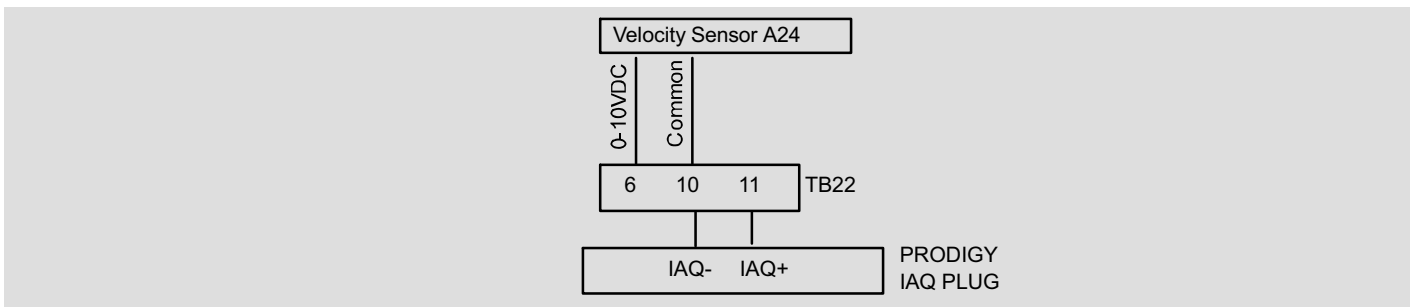

Figure 16. OAC Sensor Wiring

7.12.4.2. Set Damper Minimum Position

1. Operate unit at full supply air CFM with all zone dampers open. Refer to VFD Supply Air Blower Start-Up section in the unit installation instruction.
2. Use an air flow hood to measure the outdoor air CFM entering the unit.
3. Set economizer DIP switch to "DSET" position as shown in figure 17. DIP switch is located in the economizer section.
4. Adjust the MIN POS SET potentiometer until the air flow hood reads the design minimum outdoor air CFM (see figure 17.)

NOTE - Refer to local codes or authorities having jurisdiction when determining design minimum outdoor air requirements.

5. Return the economizer DIP switch to original position.

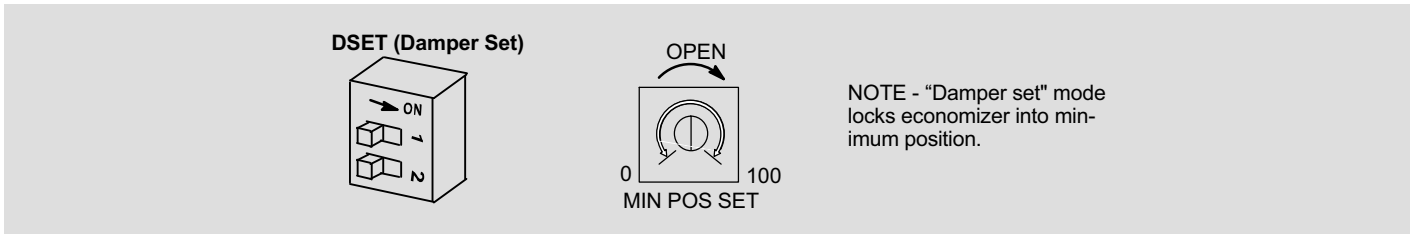

Figure 17. Economizer Manual Damper Set DIP Switch

7.12.4.3. Set Velocity Sensor Range

The velocity sensor is factory-set for 0-5m/s. (0-984ft/min.) If a higher velocity is required, move the sensor jumper as shown in figure 18.

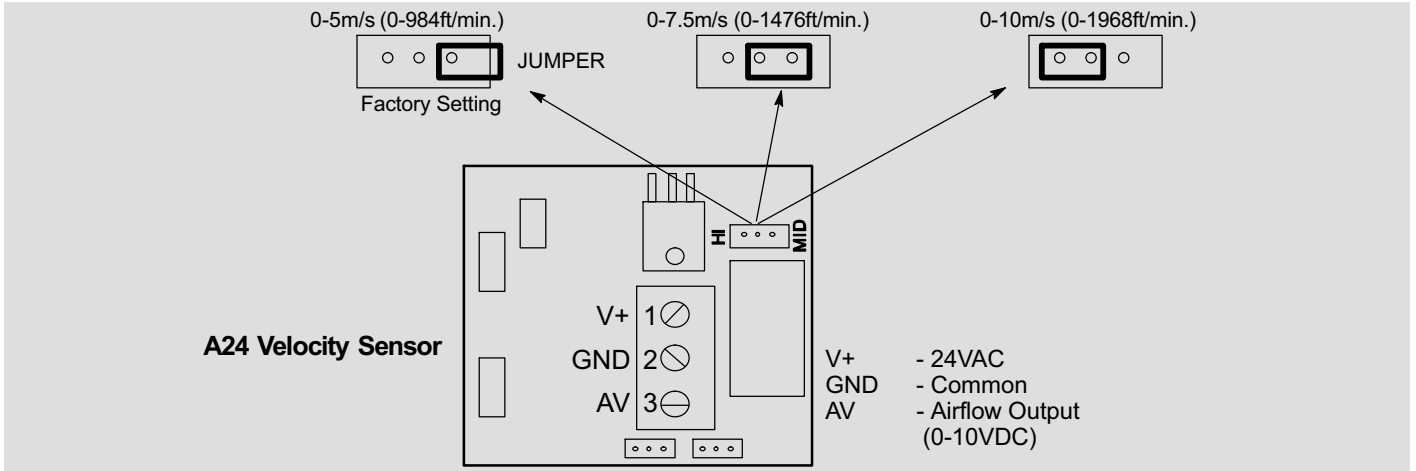

Figure 18. Velocity Sensor (A24) Range

7.12.4.4. Set Velocity Set point

1. Measure DC voltage between TB22-6 and TB22-10.
2. Multiply DC voltage by 25.4.
3. Round to the nearest whole number, and enter the result in ECTO 9.02.

Table 27. Outdoor Air Control ECTO Parameter Summary

Control Parameter		Control Value			Units	Description																																																																																				
No.	Name	Min	Default	Max.																																																																																						
5.17	OAC_Dampr_Start_Open_SP	0	2.51	10	R: Volt	Damper "start open" set point for Outdoor Air Control. Level where fresh air damper begins to open.																																																																																				
5.18	OAC_Dampr_Full_Open_SP	0	5.02	10	R: Volt	Damper "full open" set point for Outdoor Air Control. Level where fresh air damper is opened to maximum.																																																																																				
5.26	IAQ_Input_Source/Mode	0	0	5	Option	IAQ input source and mode (0-3 operate only when blower is on). 0- DCV System IAQ. Either P298-3 or network IAQ with no OAT limits. 1- DCV System IAQ. Either P298-3 or network IAQ with no OAT limits. 2- Outdoor Air Control Sensor A24 (A133_P194-6) (TB22-6). 3- Outdoor Air Control Sensor A24 (A133_P194-6) (TB22-6) with no OAT limits. 4- DCV System IAQ. Either P298-3 or network IAQ with blower on/auto operation. 5- DCV System IAQ. Either P298-3 or network IAQ with blower on/auto operation with no OAT limits.																																																																																				
9.01	A01_control_mode	0	0	11	Option	Analog output channel 1 control mode. 0 - No operation. Analog Output 1 off. <table border="0"> <tr> <td></td> <td>Enabled When</td> <td>Control</td> </tr> <tr> <td>1-</td> <td>Occupied</td> <td>PID set point A</td> </tr> <tr> <td></td> <td>Unoccupied</td> <td>PID set point B</td> </tr> <tr> <td>2-</td> <td>Occupied</td> <td>PID set point A</td> </tr> <tr> <td></td> <td>Unoccupied</td> <td>Staged output B</td> </tr> <tr> <td>3-</td> <td>Occupied</td> <td>Staged output A</td> </tr> <tr> <td></td> <td>Unoccupied</td> <td>PID set point B</td> </tr> <tr> <td>4-</td> <td>Occupied</td> <td>Staged output A</td> </tr> <tr> <td></td> <td>Unoccupied</td> <td>Staged output B</td> </tr> <tr> <td>5-</td> <td>Blower On</td> <td>PID set point A</td> </tr> <tr> <td></td> <td>Blower Off</td> <td>PID set point B</td> </tr> <tr> <td>6-</td> <td>Blower On</td> <td>PID set point A</td> </tr> <tr> <td></td> <td>Blower Off</td> <td>Staged output B</td> </tr> <tr> <td>7-</td> <td>Blower On</td> <td>Staged output A</td> </tr> <tr> <td></td> <td>Blower Off</td> <td>PID set point B</td> </tr> <tr> <td>8-</td> <td>Blower On</td> <td>Staged output A</td> </tr> <tr> <td></td> <td>Blower Off</td> <td>Staged output B</td> </tr> <tr> <td>9 -</td> <td>DI2 (A133_P194-2) on</td> <td>PID set point B (1)</td> </tr> <tr> <td></td> <td>DI1 (A133_P194-1) on</td> <td>PID set point A (2)</td> </tr> <tr> <td></td> <td>Otherwise off</td> <td></td> </tr> <tr> <td>10-</td> <td>DI2 (A133_P194-2) on</td> <td>PID set point B (1)</td> </tr> <tr> <td></td> <td>DI1 (A133_P194-1) on</td> <td>Staged output A (2)</td> </tr> <tr> <td></td> <td>Otherwise off</td> <td></td> </tr> <tr> <td>11-</td> <td>DI2 (A133_P194-2) on</td> <td>Staged output B (1)</td> </tr> <tr> <td></td> <td>DI1 (A133_P194-1) on</td> <td>Staged output A (2)</td> </tr> <tr> <td></td> <td>Otherwise off</td> <td></td> </tr> <tr> <td></td> <td>(1) -DI1 (A133_P194-2) doesn't matter</td> <td></td> </tr> <tr> <td></td> <td>(2) -DI2 (A133_P194-1) is off</td> <td></td> </tr> </table>		Enabled When	Control	1-	Occupied	PID set point A		Unoccupied	PID set point B	2-	Occupied	PID set point A		Unoccupied	Staged output B	3-	Occupied	Staged output A		Unoccupied	PID set point B	4-	Occupied	Staged output A		Unoccupied	Staged output B	5-	Blower On	PID set point A		Blower Off	PID set point B	6-	Blower On	PID set point A		Blower Off	Staged output B	7-	Blower On	Staged output A		Blower Off	PID set point B	8-	Blower On	Staged output A		Blower Off	Staged output B	9 -	DI2 (A133_P194-2) on	PID set point B (1)		DI1 (A133_P194-1) on	PID set point A (2)		Otherwise off		10-	DI2 (A133_P194-2) on	PID set point B (1)		DI1 (A133_P194-1) on	Staged output A (2)		Otherwise off		11-	DI2 (A133_P194-2) on	Staged output B (1)		DI1 (A133_P194-1) on	Staged output A (2)		Otherwise off			(1) -DI1 (A133_P194-2) doesn't matter			(2) -DI2 (A133_P194-1) is off	
	Enabled When	Control																																																																																								
1-	Occupied	PID set point A																																																																																								
	Unoccupied	PID set point B																																																																																								
2-	Occupied	PID set point A																																																																																								
	Unoccupied	Staged output B																																																																																								
3-	Occupied	Staged output A																																																																																								
	Unoccupied	PID set point B																																																																																								
4-	Occupied	Staged output A																																																																																								
	Unoccupied	Staged output B																																																																																								
5-	Blower On	PID set point A																																																																																								
	Blower Off	PID set point B																																																																																								
6-	Blower On	PID set point A																																																																																								
	Blower Off	Staged output B																																																																																								
7-	Blower On	Staged output A																																																																																								
	Blower Off	PID set point B																																																																																								
8-	Blower On	Staged output A																																																																																								
	Blower Off	Staged output B																																																																																								
9 -	DI2 (A133_P194-2) on	PID set point B (1)																																																																																								
	DI1 (A133_P194-1) on	PID set point A (2)																																																																																								
	Otherwise off																																																																																									
10-	DI2 (A133_P194-2) on	PID set point B (1)																																																																																								
	DI1 (A133_P194-1) on	Staged output A (2)																																																																																								
	Otherwise off																																																																																									
11-	DI2 (A133_P194-2) on	Staged output B (1)																																																																																								
	DI1 (A133_P194-1) on	Staged output A (2)																																																																																								
	Otherwise off																																																																																									
	(1) -DI1 (A133_P194-2) doesn't matter																																																																																									
	(2) -DI2 (A133_P194-1) is off																																																																																									
9.02	AO1_SP_A	0 0 -0.5 0	127 5.00 0 2.5	255 10.0 0.5 5.0	Counts R:Volts M:"w.c. N:"w.c.	Analog output channel 1 set point A																																																																																				
9.09	AO1_PID_P_Constant	0	0	127	Counts	Analog output channel 1 PID loop proportional constant.																																																																																				
9.10	AO1_PID_I_Constant	0	0	127	Counts	Analog output channel 1 PID loop integral constant.																																																																																				

8. Power Exhaust Operation

8.1. Single Fan or Blower

The M2 has several exhaust control options selected by ECTO 8.16. The default operation, option 0, is single-stage energized when the fresh air damper opens to 50% Travel (ECTO 8.20). The blower must be operating.

Units equipped with an A133 (GP) board with the DIP configuration switch set to VAV, may control the fan by a building pressure switch (S37 or S39) or a pressure transducer (A34).

8.2. Two Fans or Blowers

Units equipped with two-stage exhaust fan and A133 (GP) board with the DIP configuration switch set to VAV, may control the fan stage by two fresh air damper position set points, two pressure switches or from two pressure sensor set points.

8.3. Exhaust Blower VFD

Units equipped with a power exhaust VFD and A133 (GP) board with the DIP configuration switch set to VAV, may vary the speed of the blower to maintain a building pressure set point.

There are four exhaust fan enable options to choose from when the unit is equipped with a GP board:

1. On when blower is energized.
2. On always.
3. On during occupied period.
4. On if optional digital input A133_P194_1 is energized.

See table 28 for more details.

Table 28. ECTO 8.16 Exhaust Control

Option ECTO 8.16	Single-Stage Exhaust		Set points			Dead-band	
	Enabled when	Input	Default	ECTO	Default	ECTO	
0	Blower is energized.	Fresh Air Damper Position	50% Travel	8.20	10% Travel	8.21	
<p>CAV units with single stage exhaust fans use the A55_P265-11 output to energize the exhaust relay when the fresh air damper position reaches 50% Travel (ECTO 8.20) when the blower is operating. The exhaust will de-energize when the damper position decreases 10% (ECTO 8.21) less than the set point or when the blower is de-energized.</p> <p>VAV units with VFDs could use this option for single stage operation. In that case, the A55_P265-11 output is used to enable the VFD and the exhaust fan will operate at speed set with ECTO 8.17 (50% default).</p>							
1	Always	A133 Digital Input 1 (P194-1)(TB18-1) (Pressure Switch S37)	Input energized by pressure switch setting.				
2	Occupied						
3	Blower is energized.						
<p>On units equipped with an A133 board set for VAV operation, the exhaust fan will be energized when enabled and the Digital Input 1 is energized. This option typically would have a building pressure switch connected to the Digital Input.</p> <p>VAV units with VFDs could use this option for single stage operation. In that case, the A55_P265-11 output is used to enable the VFD and the exhaust fan will operate at speed set with ECTO 8.17 (50% default).</p>							
4	Always	A133 Analog Input 2 (P194-7) (TB18-7) (Pressure Sensor A34)	-0.3"w.c.(1)	8.20	0.04"w.c.(1)	8.21	
5	Occupied						
6	Blower is energized						
7	A133 Digital Input 1 (P194-1) is energized (enable switch)						
<p>(1) Settings require adjustment in most cases.</p> <p>CAV units equipped with an A133 board set for VAV operation, the power exhaust will be energized when enabled and the Analog Input voltage is at or above ECTO 8.20 setting. Exhaust air will de-energize when the voltage decreases by the dead-band set with ECTO 8.21. This option typically would have a building pressure sensor connected to the Analog Input.</p> <p>VAV units with VFDs could use this option for single stage operation. In that case, the A55_P265-11 output is used to enable the VFD and the exhaust fan will operate at speed set with ECTO 8.17 (50% default)</p>							
	Two-Stage Exhaust	Input1	Input2	Set points		#	Dead-band
8	Blower is energized	Fresh Air Damper Position	50% Travel	8.20	1	20% Travel	8.23
			10% Travel	8.21	2	64% Travel	8.24
<p>(1) Settings must be adjusted for proper operation.</p> <p>Units equipped with an A133 board set for VAV operation and two-stage exhaust fans use the A55_P265-11 output to energize the exhaust relay for stage one when the fresh air damper position reaches 50% Travel (ECTO 8.20) when the blower is operating. The A133_P194-5 output energizes exhaust fan relay (K201) for stage two when the fresh air damper position reaches (ECTO 8.23) when the blower is operating. ECTO 8.23 must be adjusted for this operation. Stage 2 will de-energize when the damper position decreases the % set with ECTO 8.24 less than the set point or when the blower is de-energized. Stage two will not energize until 0 seconds default (ECTO 8.25) after stage one. Stage 1 will not de-energize until stage two has been de-energized for 100 Seconds (ECTO8.22).</p>							

Option ECTO 8.16	2-Stage Exhaust (cont'd) Enabled when	Input1	Input2	Set points		#	Dead-band	
				Default	ECTO		Default	ECTO
9	Always	A133 Digital Input 1 (P194-1)(TB18-1) (Pressure Switch S37)	A133 Digital Input 2 (P194-2) (Pressure Switch S39)	Input energized by pressure switch setting.				
10	Occupied							
11	Blower is energized							

Units equipped with an A133 board set for VAV operation and two-stage exhaust fans use the A55_P265-11 output to energize the exhaust relay for stage one when enabled. Stage two will not energize until 0 seconds default (ECTO 8.25) after stage one. Stage 1 will not de-energize until stage two has been de-energized for 100 Seconds (ECTO 8.22).

VAV units with VFDs could use this option for two stage operation. In that case, the A55_P265-11 output is used to enable the VFD and the exhaust fan will operate at speed set with ECTO 8.17 (50% default) for stage 1 and ECTO 8.18 for stage 2.

12	Always	A133 Analog Input 2 (TB18-7)(P194-7) (Pressure Sensor A34)	-0.3"w.c.	8.20	1	0.04 VDC	8.21
			-0.42"w.c.(1)	8.23	2	0.25"w.c.(1)	8.24
13	Occupied		-0.3"w.c.	8.20	1	0.04 VDC	8.21
			-0.42"w.c.(1)	8.23	2	0.25"w.c.(1)	8.24
14	Blower is energized		-0.3"w.c.	8.20	1	0.04 VDC	8.21
			-0.42"w.c.(1)	8.23	2	0.25"w.c.(1)	8.24
15	A133 Digital Input 1 (P194-1) is energized (Enable Switch)		-0.3"w.c.	8.20	1	0.04 VDC	8.21
			-0.42"w.c.(1)	8.23	2	0.25"w.c.(1)	8.24

(1) Settings must be adjusted for proper operation.

Units equipped with an A133 board set for VAV operation and two-stage exhaust fans use the exhaust fan relay for stage one when Digital Input 1 (P194-1) is energized and enabled. The A133_P194-5 output energizes the exhaust fan relay K201 for stage two when Digital Input 2 (P194-2) is energized and enabled. Stage two will not energize until 0 seconds default (ECTO 8.25) after stage one. Stage 1 will not de-energize until stage two has been de-energized for 100 Seconds (ECTO 8.22). This option typically would have two building pressure switches connected to the two Digital Inputs.

VAV units with VFDs could use this option for two stage operation. In that case, the A55_P265-11 output is used to enable the VFD and the exhaust fan will operate at speed set with ECTO 8.17 (50% default) for stage 1 and ECTO 8.18 (100% default) for stage 2.

Option ECTO 8.16	VFD Exhaust With Low Speed Cycling		Set points		Set points During Smoke Alarm		Minimum Speed	
	Enabled when	Input	Default	ECTO	Default	ECTO	Default	ECTO
16	Always	A133 Analog Input 2 (TB18-7) (P194-7) (Pressure Sensor A34)	-0.30"w.c.	8.20	-0.30"w.c.	8.19	10% (1)	8.21
17	Occupied							
18	Blower is energized							
19	A133 Digital Input 1 (P194-1) is energized (Enable Switch)							

(1) Settings must be adjusted for proper operation.

Units with exhaust VFDs use this option for variable speed exhaust operation. The A55_P265-11 output is used to enable the VFD. The VFD will vary the exhaust motor speed to maintain the static pressure set point (ECTO 8.20). ECTO 8.20 must be adjusted for this operation. If exhaust operates at minimum speed for a time period of 30 seconds, it will de-energize for a minimum time period of 30 seconds. Exhaust will energize when feedback exceeds the set point by 10%. This option typically would have a building pressure sensor connected to the Analog Input. The PID loop proportional (P) constant may be adjusted by ECTO 8.23, integral (I) constant may be adjusted by ECTO 8.24, derivative may be adjusted by ECTO 8.25 and the reset value may be adjusted by ECTO 8.22.

	VFD Exhaust		Set points		Set points During Smoke Alarm		Minimum Speed	
20	Always	A133 Analog Input 2 (TB18-7)(P194-7)(Pres- sure Sensor A34)	-0.30"w.c.	8.20	-0.30"w.c.	8.19	10% (1)	8.21
21	Occupied							
22	Blower is energized							
23	A133 Digital Input 1 (P194-1) is energized (Enable Switch)							

(1) Settings must be adjusted for proper operation.

Units with exhaust VFDs use this option for variable speed exhaust operation. The A55_P265-11 output is used to enable the VFD. The VFD will vary the exhaust motor speed to maintain the static pressure set point (ECTO 8.20). ECTO 8.20 must be adjusted for this operation. Exhaust fan will not cycle off while enabled. This option typically would have a building pressure sensor connected to the Analog Input. The PID loop proportional (P) constant may be adjusted by ECTO 8.23, integral (I) constant may be adjusted by ECTO 8.24, derivative may be adjusted by ECTO 8.25 and the reset value may be adjusted by ECTO 8.22.

9. Supply Air Delivery

9.1. Blower Delays

The following examples describe blower function for constant air volume (CAV) applications.

9.1.1. Gas / Electric Units:

The blower is delayed 40 seconds (default ECTO 3.02) after the gas valve is energized and 120 seconds (default ECTO 3.03) after the gas valve is de-energized. The blower operates anytime a heat limit trips.

9.1.2. Electric / Electric Units:

The default on delay is set to 0 (ECTO 2.02). The blower is delayed off for 20 seconds (default ECTO2.03) after the heating demand is terminated.

9.1.3. Cooling Operation:

The default on and off delays are 0, but may be adjusted by ECTOs 4.02 or 4.03. The on-delay time period starts when the cooling demand is initiated. The off-delay time period starts when the cooling demand is terminated.

9.1.4. Heat Pump Operation:

The default on-delay is 0 (ECTO 1.02), but the off-delay default is 20 seconds (ECTO 1.03). The on-delay time period starts when the heat pump heating demand is initiated. The off-delay time period starts when the heat pump heating demand is terminated. The following chart summarizes blower delays.

Unit operation	Blower On Delay		Blower Off Delay	
	Default	ECTO	Default	ECTO
Gas Heating	40 Sec.	3.02	120 Sec.	3.03
Electric Heating	0 Sec.	2.02	20 Sec.	2.03
Cooling	0 Sec.	4.02	0 Sec.	4.03
HP Heating	0 Sec.	1.02	20 Sec.	1.03

9.2. Supply VAV Control Mode

The M2 uses the General Purpose GP1 board to control optional supply air and power exhaust blower variable frequency drives (VFD). The DIP switch on the GP1 board must be set to VAV. The GP1 controls the supply air VFD or by-pass damper in response to a duct static pressure reading. VFD powered blowers can be varied or staged.

The GP1 sensor inputs and VFD outputs are 0-10VDC. Duct static pressure sensor (A30) is 0-5"w.c.

The M2 has a maximum supply duct pressure limit (ECTO 0.21, default 2"w.c.) If this limit is exceeded the control will shut off the unit. After an off delay time of 5 minutes (ECTO 5.02), the blower will re-energize. The control will lockout on the third trip (ECTO 0.22) and an M2 reset will be required.

The following examples describe air delivery for optional supply air VFD and by-pass damper configurations. Refer to table 29 for a summary of ECTO 0.01 options.

ECTO 0.01	Mode	SMK	VT	CL	HT
0	CAV	-	-	-	-
1	CAV w/bypass damper	PID	PID	PID	PID
3	VAV w/VFD (MSAV)	STG	STG	STG	STG
7	VAV w/VFD	PID	STG	STG	STG
11	VAV w/VFD	STG	PID	STG	STG
15	VAV w/VFD	PID	PID	STG	STG
19	VAV w/VFD	STG	STG	PID	STG
23	VAV w/VFD	PID	STG	PID	STG
27	VAV w/VFD	STG	PID	PID	STG
31	VAV w/VFD	PID	PID	PID	STG
35	VAV w/VFD	STG	STG	STG	PID
39	VAV w/VFD	PID	STG	STG	PID
43	VAV w/VFD	STG	PID	STG	PID
44	VAV w/VFD	PID	PID	STG	PID
51	VAV w/VFD	STG	STG	PID	PID
55	VAV w/VFD	PID	STG	PID	PID
59	VAV w/VFD	STG	PID	PID	PID
63	VAV w/VFD	PID	PID	PID	PID

STG=Staged Control; PID=PID Loop or Modulating Control

9.2.1. Local Thermostat Mode, Single Zone CAV Units

ECTO 6.01 option 0 (Default)

This configuration is used for thermostat or DDC applications when the blower is controlled by the G thermostat demand 24VAC input.

9.2.2. Zone Sensor mode, Single Zone CAV Units

ECTO 6.01 option 1,2,3

This configuration is used with an L Connection Zone sensor for single zone constant air volume application. Blower cycles with demand unless ECTO 6.17 is set to 1. In that case the blower will operate continuously during occupied periods and cycles with demands during unoccupied periods. All delays as described in Local Tstat Mode still apply.

9.2.3. Local Thermostat Mode, CAV Bypass Zoning Units

ECTO 6.01 option 0 (default) or 12

ECTO 0.01 option 1

This configuration is used for 3rd party zoning systems that utilize a blower bypass damper for controlling duct static. There are four different set points: one for cooling, one for ventilation, one for operation during smoke alarm modes, and one for heating. Blower operates when the G demand is energized. The blower also operates anytime a heat limit trips. All delays as described in Local Tstat Mode still apply. The M2 controls duct static pressure by reading the duct pressure and varying the bypass damper position between minimum and maximum positions.

The minimum/maximum damper positions and static pressure set points are listed as follows:

Operation	Minimum Position		Maximum Position		Duct Static SP	
	Default	ECTO	Default	ECTO	Default	ECTO
Cooling	20%	0.17	100%	0.19	1.00"w.c.	0.16
Ventilation	20%	0.17	100%	0.19	1.00"w.c.	0.14
Smoke Alarm Modes	20%	0.17	100%	0.19	1.00"w.c.	0.13
Heating	20%	0.18	100%	0.19	1.00"w.c.	0.15

9.2.4. L Connection Network, CAV Bypass Zoning Units

ECTO 6.01 option 4,5,6,7;

ECTO 0.01 option 1

This configuration is used for L Connection Zoning that utilizes a blower bypass damper for controlling duct static. There are four different set points: one for cooling, one for ventilation, one for operation during smoke alarm modes, and one for heating. Network commands energize the blower. Blower will cycle with demand unless ECTO 6.17 is set to 1. In that case, the blower will operate continuously during occupied periods and will cycle during unoccupied periods. Blower also operates anytime a heat limit trips. All delays as described in Local Tstat Mode still apply.

The M2 controls duct static pressure by reading the duct pressure and varying the bypass damper position between and minimum and maximum positions. The min/max damper positions and static pressure set points are listed as follows:

Operation	Minimum Position		Maximum Position		Duct Static SP	
	Default	ECTO	Default	ECTO	Default	ECTO
Cooling	20%	0.17	100%	0.19	1.00"w.c.	0.16
Ventilation	20%	0.17	100%	0.19	1.00"w.c.	0.14
Smoke Alarm Modes	20%	0.17	100%	0.19	1.00"w.c.	0.13
Heating	20%	0.18	100%	0.19	1.00"w.c.	0.15

9.2.5. Local Thermostat Mode, VAV units

ECTO 6.01 option 0 (default) or 12;

ECTO 0.01 option 63

This configuration is used for 3rd party VAV zoning systems. Blower speed is controlled by the factory installed VFD between a minimum and maximum speed to maintain duct static pressure set points. There are four different set points: one for cooling, one for ventilation, one for operation during smoke alarm modes, and one for heating. The blower is enabled by a G demand. The M2 controls the duct static pressure by reading the duct pressure and varying the blower speed on units with VFDs.

The minimum/maximum speed and static pressure set points are listed as follows:

Operation	Minimum Speed		Maximum Speed		Duct Static SP	
	Default	ECTO	Default	ECTO	Default	ECTO
Cooling	50%	0.06	100%	0.08	1.00"w.c.	0.05
Ventilation	50%	0.06	100%	0.08	1.00"w.c.	0.03
Smoke Alarm Modes	50%	0.06	100%	0.08	1.00"w.c.	0.02
Heating	50%	0.07	100%	0.08	1.00"w.c.	0.04

9.2.6. Local Thermostat Mode, VAV staged units

ECTO 6.01 option 0 (default) or 12; ECTO 0.01 option 3 (MSAV) This configuration is a special case application where the blower speed is staged by the factory installed VFD for fixed speeds for different operation. There are seven different speed stages, one for each cooling compressor stage (4), one for ventilation, one for heating and one for operation during smoke alarm modes. The blower is enabled by a G demand. This table shows the default staged speeds.	Operation	Staged Speed	
		(1)Default	ECTO
	Cooling compressor 1	51%	0.05
	Cooling compressor 2	51%	0.14
	Cooling compressor 3	51%	0.15
	Cooling compressor 4	51%	0.16
	Ventilation or economizer free cooling	51%	0.03
	Smoke Alarm Modes	51%	0.02
	Heating	51%	0.04
(1)Staged % speed must be adjusted for each operation.			

9.2.7. L Connection Network, VAV units

**ECTO 6.01 option 4, 5, 6, or 7;
ECTO 0.01 option 63**

This configuration is used for L Connection VAV zoning systems. There are four different set points: one for cooling, one for ventilation, one for operation during smoke alarm modes, and one for heating. Network commands energize the blower. Blower will cycle with demand unless ECTO 6.17 is set to 1. In that case the blower will operate continuously during occupied periods and will cycle during unoccupied periods. Network commands controls occupied/unoccupied periods.

All delays as described in Local Tstat Mode still apply. Blower speed is controlled by the factory installed VFD between a minimum and maximum speed to maintain duct static pressure set points. There are three different set points, one for cooling, one for ventilation and one for operation during smoke alarm modes. The M2 controls the duct static pressure by reading the duct pressure and varying the blower speed on units with VFDs

The min/max. speed and static pressure set points are listed below:

Operation	Minimum Position		Maximum Position		Duct Static SP	
	Default	ECTO	Default	ECTO	Default	ECTO
Cooling	50%	0.06	100%	0.08	1.00"w.c.	0.05
Ventilation	50%	0.06	100%	0.08	1.00"w.c.	0.03
Smoke Alarm Modes	50%	0.06	100%	0.08	1.00"w.c.	0.02
Heating	50%	0.07	100%	0.08	1.00"w.c.	0.04

9.2.8. VAV Staged Units: A Box (3- to 5-ton units)

Energence A Box 3- to 5-ton units use a single, 2-step capacity, compressor. These units use a variable output blower that operates at high or low. (***The 6-ton Energence A Box has a single capacity compressor, and a single speed blower, so it is not an MSAV type of unit, and the following does not apply to it.***)

High efficiency Energence A Box units use a direct-drive ECM constant torque motor. The blower runs at a selected high or low output depending on unit operation. The actual blower speed and CFM delivered will depend on the flow restriction as well as the percent output. The blower output for each mode of operation has been factory set, but it will need to be adjusted based on the installed duct-work and the air delivery required for the application. The table shows the default blower output and the ECTO location where the output value for the each mode is stored. The default blower output selection for smoke mode operation is the same as high speed, but it can be set to a different value using ECTO 0.02.

Standard efficiency Energence A Box unit use a belt-drive 2-speed motor. The blower runs at low or high speed depending on unit operation, but the speed is not ECTO-selectable. High speed blower runs during smoke mode operation. The table also shows, for units equipped with an economizer or motorized outdoor air damper, the damper percent output when the blower is running and the space is occupied. The default value of 101 for ECTO 5.24 is used to indicate that the min position potentiometer on the M2 board is used to set the high-blower damper position. Setting ECTO 5.24 to a value in the range of 0-100 causes this value to be used for the damper minimum position during high blower operation.

High Efficiency Factory Settings (as percent output) - A Box (3- to 5-ton units)				
Operation	3- ton	4- ton	5- ton	ECTO
Cooling low, Free cooling low, Ventilation low	28	40	36	0.05
Cooling high, Free cooling high, Ventilation high, Heating	55	80	59	0.04
Smoke alarm modes	55	80	59	0.02
Minimum damper during low blower	30			0.09
Minimum damper during high blower	101			5.24

9.2.9. VAV Staged Units: B, C, D, and E Boxes

ECTO 0.01 option 3 (MSAV)	Operation	Staged Speed	
		(1)Default	ECTO
<p>This configuration is a special-case application where the blower speed is staged by the factory installed VFD for fixed speeds for different operation. There are seven different speed stages, one per cooling stage (4), one for ventilation, one for heating and one for operation during smoke alarm modes. Network commands energize the blower which will cycle with demand.</p>	Cooling compressor 1	51%	0.05
	Cooling compressor 2	51%	0.14
	Cooling compressor 3	51%	0.15
	Cooling compressor 4	51%	0.16
	Ventilation or economizer free cooling	51%	0.03
	Smoke Alarm Modes	51%	0.02
	Heating	51%	0.04
	(1) Staged % speed must be adjusted for each operation.		

9.3. VFD Control

	Speed %	Motor Frequency (Hz)	VFD Control Voltage (VDC)
<p>The M2 is only compatible with the factory installed variable frequency drives (VFD) in VAV units used to control the supply blower and exhaust fan(s). The analog control for the VFDs is 0-10VDC. This manual uses percent (%) for all blower and fan speeds. For example, 50% blower speed equals 30Hz equals 5VDC.</p>	0	0	0
	10	6	1
	20	12	2
	30	18	3
	40	24	4
	50	30	5
	60	36	6
	70	42	7
	80	48	8
	90	54	9
	100	60	10

9.4. Supply Bypass Damper Control

	Bypass Damper Position (%)	Control Voltage (VDC)
<p>The M2 is only compatible with bypass damper actuators specified in the Engineering Handbook. Specified dampers are used to control the supply air volume for constant air volume w/bypass damper (CAVB) zoning applications. The analog control for the actuator is a 2-10VDC with 10VDC being fully closed. This manual uses percent (%) for bypass damper position. For example, 70% bypass damper position equals 4.4VDC.</p>	0 (closed)	10
	10	9.2
	20	8.4
	30	7.6
	40	6.8
	50	6.0
	60	5.2
	70	4.4
	80	3.6
	90	2.8
	100	2.0

9.5. Analog Output Control

The analog outputs on the GP1 boards can be set to closed loop PID or staged control. Most applications such as variable air delivery and variable speed exhaust fans will use the closed loop PID option. The closed loop PID method used by the M2 has four constants, manual reset (ManRS), proportional (P), integral (I) and derivative (D) as shown in figure 19. The PID control constants as well as the output minimum and maximum values, may be adjusted if necessary.

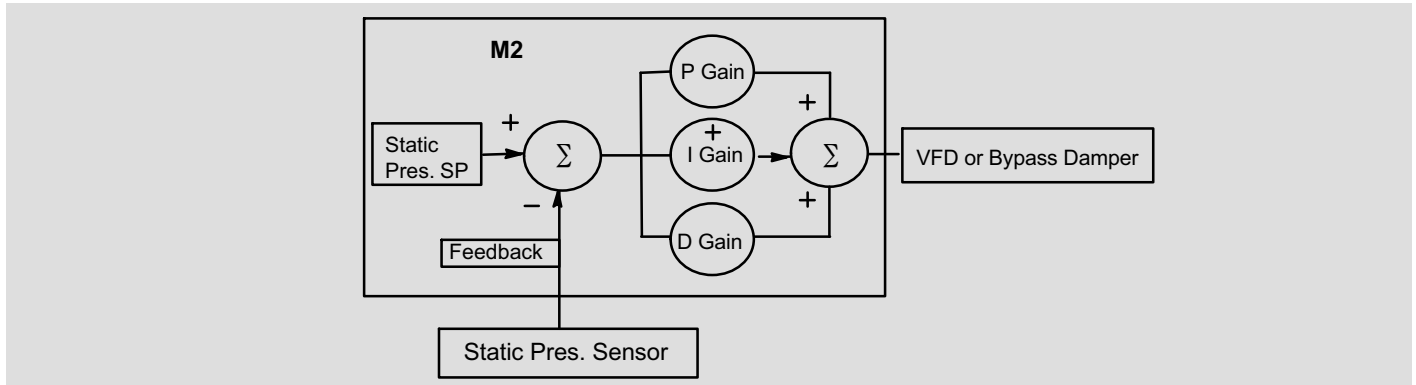

Figure 19. PID Operation Diagram for VAV/CAVB Air Delivery and Exhaust Fan Control

9.5.1. Manual Reset (ManRS)

The output value when the P, I, and D values are all 0. This is the approximate output expected which allows quicker settling at set point. On CAV units with bypass damper, this is also the damper position when blower is off. ManRS can be adjusted between a minimum value and 100%.

9.5.2. Proportional Constant (P)

To handle the present, this is the value of the “gain” that is multiplied times the error. The error is the difference between the output and the set point. A large value of “P” will cause the output to reach the set point faster, however, this faster rate can cause the output to overshoot the set point. On the other hand, a low value of “P” will reduce overshoot, but will cause the output reaction to be too slow. The “P” constant ECTO value can be adjusted between 0–127 with 0 being off and 127 being the highest value.

9.5.3. Integral Constant (I)

To handle the past, this gain is proportional to the amount of time that the error is present. This gain tries to integrate out any offset. A high value of “I” can provide fast correction but can cause overshoot and ringing. The “I” gain should be set to the lowest value possible that corrects the offset. “I” can be adjusted between 0-127 with 127 being the lowest value. The “I” constant ECTO value is inverted. A value of 0 turns the integral factor off. A value of 127 is the minimum and 1 is the maximum.

9.5.4. Derivative Constant (D)

To handle the future, this gain is proportional to the rate of change of the error and provides a damping factor. The “D” constant ECTO value can be adjusted between 0- 127 with 0 being off and 127 being the highest value. Most M2 applications do not require using any “D” gain.

9.5.5. Tuning

In the event that the PID loop requires tuning, the following two methods are recommended depending on the severity of the problem:

1. In most cases the parameters will only need a small adjustment. In that case use the following table as a basic guide.

Change Desired	ECTO “P” Parameter	ECTO “I” Parameter	ECTO “D” Parameter
Reduce Response time	Increase	Decrease	Decrease
Reduce Overshoot	Decrease	Increase	Increase
Reduce Settling Time	-	Decrease	Decrease
Reduce Offset (steady state error)	Increase	Decrease	-

2. If method 1 adjustment does not stabilize the system, you may use the following tuning method:

NOTE - To use this method the system must be allowed to operate at the manual reset value (% output) without damaging the system.

- A Set the P, I and D constants to 0 (off).

- B** Start system. Analog output value will be at the ManRS value (%).
- C** Monitor system. System should be stable. If system is not stable at this point check for other problems. Adjusting the PID parameters will not solve this problem.
- D** If system is stable, gradually increase the "P" parameter until system starts oscillating (moving above and below set point, continuously).
- E** Reduce the "P" parameter to 40-70% of the value set in step 6.
- F** Gradually start adding some "I" by setting the "I" ECTO parameter to 127 and reduce setting until the steady state error (offset) is reduced to an acceptable level.
- G** If necessary, increase the "D" parameter to reduce overshoot. Use of "D" can increase settling time and/or lead to instability.
- H** NOTE - In most cases, it's best to not use any "D" parameter.

Table 30. Summary of PID Constants ECTO Parameters

Variable Air Delivery PID Constants						
No.	Name	Min	Default	Max	Units	Description
0.09	VAV_PID_ManRS	0 0	60 60	100 100	Counts P:%	VAV supply PID manual reset value. If minimum output, ECTO 0.06 or 0.07 is greater, a computed ManRS value is used. See ECTO 0.06 and 0.07.
0.10	PID_P_Constant	0	17	127	Counts	VAV or CAVB supply PID Proportional constant.
0.11	PID_I_Constant	0	12	127	Counts	VAV or CAVB supply PID Integral constant.
0.12	PID_D_Constant	0	0	127	Counts	VAV or CAVB supply PID derivative constant.
VAV Exhaust Fan PID Control Constants						
8.22	Exh_Fan_ManRS	0 0	50 50	100 100	Counts P: %	Exhaust fan PID loop manual reset value.
	Stg_1_Off_Delay	0	100	200	A:Sec.	Stage 1 off-delay. (Only used for 2 stage operation)
8.23	Exh_Fan_PID_P_Constant	0	20	255	Counts	Exhaust fan PID loop proportional constant. The P constant must be limited to 127. Recommended setting = 17.
	Stg_2_SP	0 0 -0.5	.78 20 -.42	10.0 100 0.5	R:Volts P:% M:"w.c.	Staged 2 set point.
8.24	Exh_Fan_PID_I_Constant	0	64	255	Counts	Exhaust fan PID loop integral constant. The I constant must be limited to 127. Recommended setting = 12.
	Stg_2_DB	0 0	64 0.25	100 1.0	P:% L:"w.c.	Staged 2 dead-band.
8.25	Exh_Fan_PID_D_Constant	0	0	127	Counts	Exhaust fan PID loop derivative constant.
	Stg_2_On_Delay	0	0	254	A: Sec.	Staged 2 on-delay.
9.08	AO1_PID_ManRS	0 0	50 50	100 100	Counts P:%	Analog output channel 1 PID loop manual reset value.
9.09	AO1_PID_P_Constant	0	0	127	Counts	Analog output channel 1 PID loop proportional constant.
9.10	AO1_PID_I_Constant	0	0	127	Counts	Analog output channel 1 PID loop integral constant.
9.11	AO1_PID_D_Constant	0	0	127	Counts	Analog output channel 1 PID loop derivative constant.
General Purpose PID Control Constants for GP Analog Output 2 (TB22-12)						
9.19	AO2_PID_ManRS	0 0	50 50	100 100	Counts P:%	Analog output channel 2 PID loop manual reset value.
9.20	AO2_PID_P_Constant	0	0	127	Counts	Analog output channel 2 PID loop proportional constant.
9.21	AO2_PID_I_Constant	0	0	127	Counts	Analog output channel 2 PID loop integral constant.
9.22	AO2_PID_D_Constant	0	0	127	Counts	Analog output channel 2 PID loop derivative constant.

10. Discharge Air Control

10.1. Cooling

The discharge air control cooling (DACC) option automatically cycles up to 4 stages of cooling to maintain a discharge air control cooling set point (DACC_SP).

DACC option applies to gas/electric and electric /electric units only; DACC is not allowed with heat pumps units.

When an economizer is installed, adjust free cooling set point ECTO 6.23 approximately 2 degrees lower than DACC set point. This will allow free cooling to operate before DACC energizes compressors.

Refer to figure 20 for DACC cooling stages.

Adjust ECTO 5.04 to option 4 to enable discharge air control cooling.

IMPORTANT - Discharge air sensor RT6 must be moved to the supply air duct, preferably after a 90 degree branch of the main duct.

DACC is initiated by an input in one of three ways:

1. Y1 input from an external device—ECTO 6.01 must be set to 0, local thermostat mode.
2. Cooling demand while in zone sensor mode—ECTO 6.01 must be set to 1, 2, or 3.
3. L Connection network command—ECTO 6.01 must be set to 4, 5, 6 or 7.

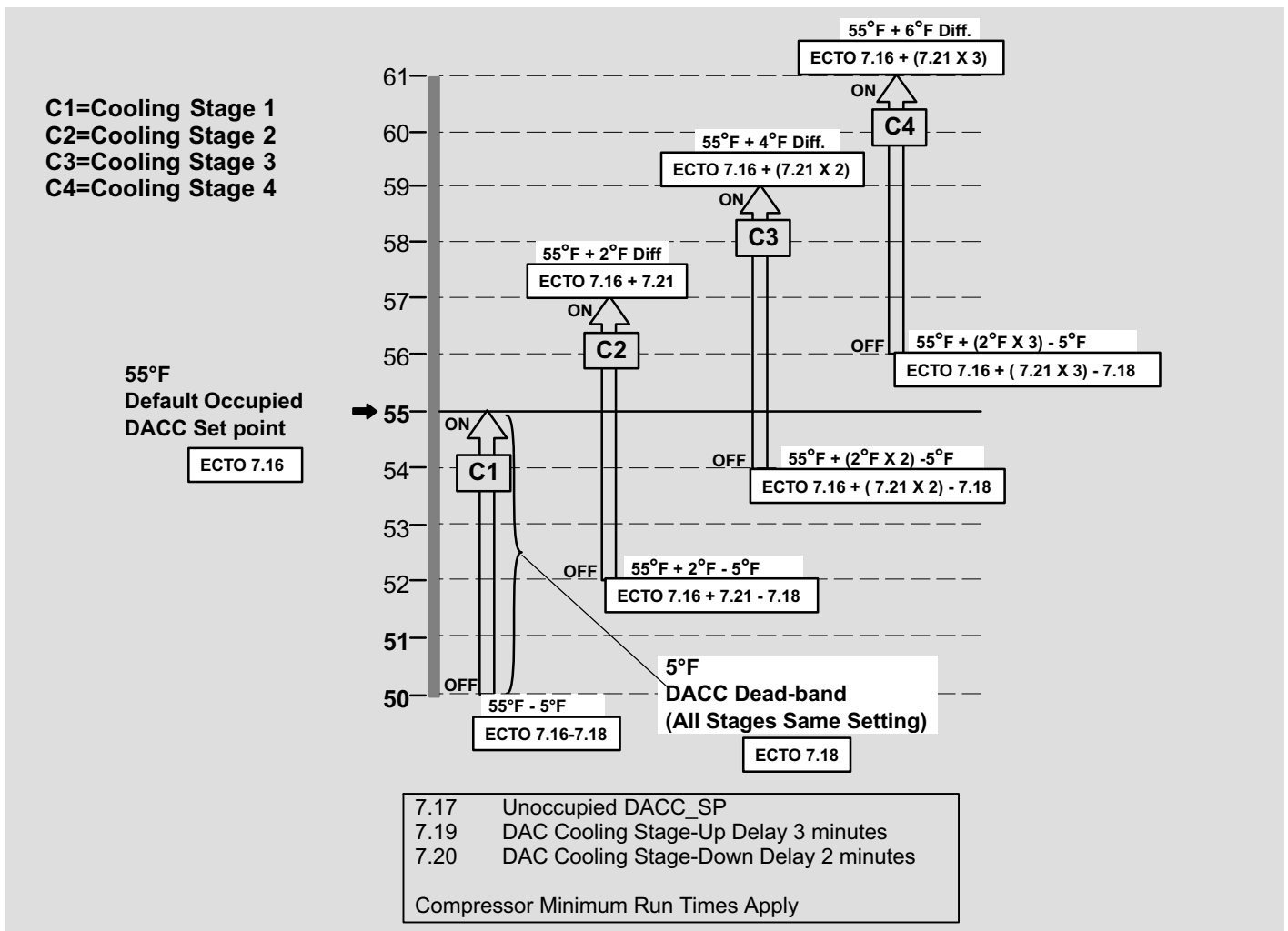

Figure 20. Discharge Air Control Cooling (DACC) Stages - Default Values Shown

10.2. Outdoor Air Reset

IMPORTANT - Outdoor air reset can be used to adjust the free cooling set point (ECTO 6.23) when DACC is not used. All references to the DACC set point apply to the free cooling set point.

The DACC and free cooling set point can be automatically reset when outdoor air temperature becomes cooler. Use ECTO 8.07 to enable Outdoor Air Reset.

For outdoor air based DACC set point reset, the discharge air cooling set point starts to increase when the outdoor air temperature (OAT) drops to the DACC_OAT_RS_SP (ECTO 8.05) (default 80°F). The reset set point will continue to increase at the rate equal to the DACC_OAT_RS_Adjustment_Band (ECTO 8.07) divided by the DACC_OAT_RS_Proportional_Band (ECTO 8.06). See the following example:

EXAMPLE: The application calls for the discharge air cooling occupied set point (DACC_OCP_SP) (ECTO 7.16) to be 55°F when OAT is 80°F or higher. When the OAT drops below 80°F, the set point needs to increase proportionately with the OAT decrease (maximum set point increase of 10°F). The 10°F OAT decrease is called the DACC_OAT_RS_Proportional_Band and the set point increase of 10°F is called the DACC_OAT_RS_Adjustment_Band. See figure 21.

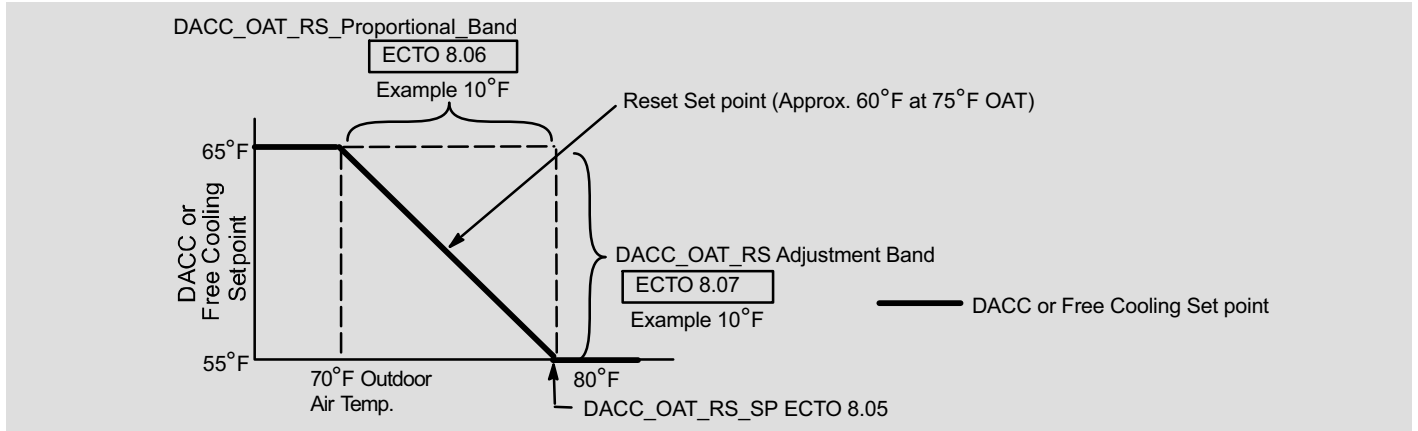

Figure 21. Outdoor Air Reset Example

To use example values, set the following parameters:

- ECTO 8.05 – DACC OAT RS SP – Set to 80°F
- ECTO 8.06 – DACC OAT RS Proportional Band – Set to 10°F
- ECTO 8.07 – DACC OAT RS Adjustment Band -- Set to 10°F (this setting enables DACC outdoor air reset).

10.3. Return Air Reset

IMPORTANT - Return air reset can be used to adjust the free cooling set point (ECTO 6.23) when DACC is not used. All references to the DACC set point apply to the free cooling set point.

The DACC and free cooling set point can be automatically reset when return air temperature becomes cooler. Use ECTO 8.04 to enable Return Air Reset.

For return air based DACC set point reset, the discharge air cooling set point starts to increase when the return air temperature (RAT) drops to the DACC_RAT_RS_SP (ECTO 8.02) (default 70°F). The reset set point will continue to increase at the rate equal to the DACC_RAT_RS_Adjustment_Band (ECTO 8.04) divided by the DACC_RAT_RS_Proportional_Band (ECTO 8.03). See the following example:

EXAMPLE: The application calls for the discharge air cooling occupied set point (DACC_OCP_SP) (ECTO 7.16) to be 55°F when RAT is 70°F or higher. When the RAT drops below 70°F, the set point needs to increase proportionately with the OAT decrease (maximum set point increase of 10°F). The 10°F RAT difference is called the DACC_RAT_RS_Proportional_Band and the set point increase of 10°F is called the DACC_RAT_RS_Adjustment_Band. See figure 22.

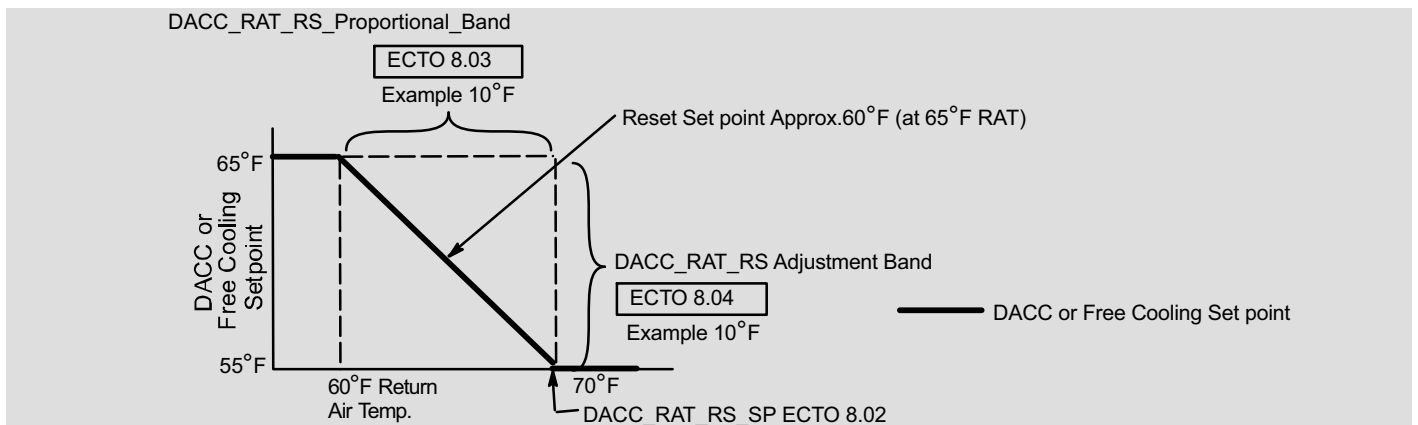

Figure 22. Return Air Reset Example

To use example values, set the following parameters:

- ECTO 8.02 – DACC_RAT_RS_SP – Set to 70°F
- ECTO 8.03 – DACC_RAT_RS_Proportional_Band – Set to 10°F
- ECTO 8.04 – DACC_RAT_RS_Adjustment_Band - Set to 10°F (this setting enables DACC return air reset).

10.4. Discharge Air Cooling Total Reset Limit

ECTO 8.01 (default=10) defines the total DACC set point reset limit. This total limit is the sum of both return and outdoor DACC resets. This parameter limits total DACC_SP adjustment band and overrides the adjustment bands for RAT and OAT (ECTO 8.07 & 8.04) if necessary.

Table 31. Discharge Air Cooling ECTO Parameters Summary

Control Parameter		Control Value			Units	Description																																										
No.	Name	Min.	Default	Max																																												
5.04	CL_Staging	0	2	4	Option	Cooling staging options: 0- No cooling operation 1- Basic Tstat operation. Two cooling stages. Units with Economizers Y1=Free Cooling, Y2=adds all mechanical stages. 2- Basic Tstat operation. Two cooling stages. Units with Economizers Y1=Free Cooling, Y2=adds first stage of mechanical. 3- Basic Tstat operation. Three cooling stages. Y1 only = first stage, Y2 only = second stage, Y1+Y2=third stage. Units with Economizers Y2 only adds first stage of mechanical, Y1+Y2 adds first and second stage of mechanical. 4- Discharge air control. Up to four stages.																																										
6.01	System_Mode	0	0	12	Option	System mode of operation. <table border="1"> <thead> <tr> <th>Control Value</th> <th>System Mode</th> <th>Backup Mode</th> </tr> </thead> <tbody> <tr><td>0</td><td>Local Thermostat</td><td>None</td></tr> <tr><td>1</td><td>Zone Sensor</td><td>None</td></tr> <tr><td>2</td><td>Zone Sensor</td><td>Local Thermostat</td></tr> <tr><td>3</td><td>Zone Sensor</td><td>Return Air Sensor</td></tr> <tr><td>4</td><td>Remote Demand</td><td>None</td></tr> <tr><td>5</td><td>Remote Demand</td><td>Local Thermostat</td></tr> <tr><td>6</td><td>Remote Demand</td><td>Return Air Sensor</td></tr> <tr><td>7</td><td>Remote Demand</td><td>Zone Sensor</td></tr> <tr><td>8</td><td>Future Use</td><td>None</td></tr> <tr><td>9</td><td>Future Use</td><td>Local Thermostat</td></tr> <tr><td>10</td><td>Future Use</td><td>Return Air Sensor</td></tr> <tr><td>11</td><td>Future Use</td><td>Zone Sensor</td></tr> <tr><td>12</td><td>A138 4-Stg. Tstat Interface</td><td>None</td></tr> </tbody> </table>	Control Value	System Mode	Backup Mode	0	Local Thermostat	None	1	Zone Sensor	None	2	Zone Sensor	Local Thermostat	3	Zone Sensor	Return Air Sensor	4	Remote Demand	None	5	Remote Demand	Local Thermostat	6	Remote Demand	Return Air Sensor	7	Remote Demand	Zone Sensor	8	Future Use	None	9	Future Use	Local Thermostat	10	Future Use	Return Air Sensor	11	Future Use	Zone Sensor	12	A138 4-Stg. Tstat Interface	None
Control Value	System Mode	Backup Mode																																														
0	Local Thermostat	None																																														
1	Zone Sensor	None																																														
2	Zone Sensor	Local Thermostat																																														
3	Zone Sensor	Return Air Sensor																																														
4	Remote Demand	None																																														
5	Remote Demand	Local Thermostat																																														
6	Remote Demand	Return Air Sensor																																														
7	Remote Demand	Zone Sensor																																														
8	Future Use	None																																														
9	Future Use	Local Thermostat																																														
10	Future Use	Return Air Sensor																																														
11	Future Use	Zone Sensor																																														
12	A138 4-Stg. Tstat Interface	None																																														
7.16	DACC_OCP_SP	124 80	161 55	183 40	Counts	Discharge Air Control Cooling set point during occupied period.																																										
7.17	DACC_UnOCP_SP	124 80	146 65	183 40	Counts X:DegF	Discharge Air Control Cooling set point during unoccupied period.																																										
7.18	DACC_Stg_DB	7 5	7 5	30 20	Counts V:DegF	Discharge Air Control Cooling stage dead-band.																																										
7.19	DACC_&_FAC_StgUp_Delay	0 0	45 180	225 900	Counts B: Sec.	Discharge Air Control Cooling and Fresh Air Cooling stage-up delay.																																										
7.20	DACC_&_FAC_StgDn_Delay	0 0	30 120	150 600	Counts B: Sec.	Discharge Air Control Cooling and Fresh Air Cooling stage-down time delay.																																										
7.21	DACC_Stg_Dif	3 2	3 2	30 20	Counts V:DegF	Discharge Air Cooling stage differential.																																										
8.01	DACC_RS_Total_LT	7 5	15 10	29 20	Counts V:DegF	Discharge Air Control Cooling total reset limit. This limits the total DACC reset allowed. Also used to reset free cooling set point (6.23).																																										
8.02	DACC_RAT_RS_SP	124 80	139 70	169 50	Counts X:DegF	Discharge Air Control Cooling return air reset set point. Also used to reset free cooling set point (6.23).																																										
8.03	DACC_RAT_RS_Proportional_Band.	1 1	15 10	44 30	Counts V:DegF	Discharge Air Control Cooling return air reset proportional band. Also used to reset free cooling set point (6.23).																																										
8.04	DACC_RAT_RS_Adjust_Band	0 0	0 0	44 30	Counts V:DegF	Discharge Air Control Cooling return air reset adjustment band. 0 disables return air cooling reset. Also used to reset free cooling set point (6.23).																																										
8.05	DACC_OAT_RS_SP	50 100	81 80	144 40	Counts Y:DegF	Discharge Air Control Cooling outdoor air temperature cooling reset set point. Also used to reset free cooling set point (6.23).																																										

Control Parameter No.	Control Parameter Name	Control Value			Units	Description
		Min.	Default	Max		
8.06	DACC_OAT_RS_Proportional_Band.	1	31	94	Counts O:DegF	Discharge Air Control Cooling outdoor ambient temperature cooling proportional band. Also used to reset free cooling set point (6.23).
8.07	DACC_OAT_RS_Adjust_Band	0	0	47	Counts O:DegF	Discharge Air Control Cooling outdoor temperature ambient cooling adjustment reset band. 0 disables outdoor air cooling reset. Also used to reset free cooling set point (6.23).

10.5. Heating

The discharge air control heating (DACH) option automatically cycles up to 4 stages of heating to maintain a discharge air control heating set point (DACH_SP).

DACH option applies to gas/electric and electric /electric units only; DACH is not allowed with heat pumps units.

Refer to figure 23 for DACH heating stages.

Adjust ECTO 5.09 to option 1 to enable discharge air control.

IMPORTANT - Discharge air sensor RT6 must be moved to the supply air duct, preferably after a 90 degree branch off of the main duct.

DACH is initiated by an input in one of three ways:

1. W1 input from an external device—ECTO 6.01 must be set to 0, local thermostat mode.
2. Heating demand while in zone sensor mode—ECTO 6.01 must be set to 1, 2, or 3.
3. L Connection network command—ECTO 6.01 must be set to 4, 5, 6 or 7.

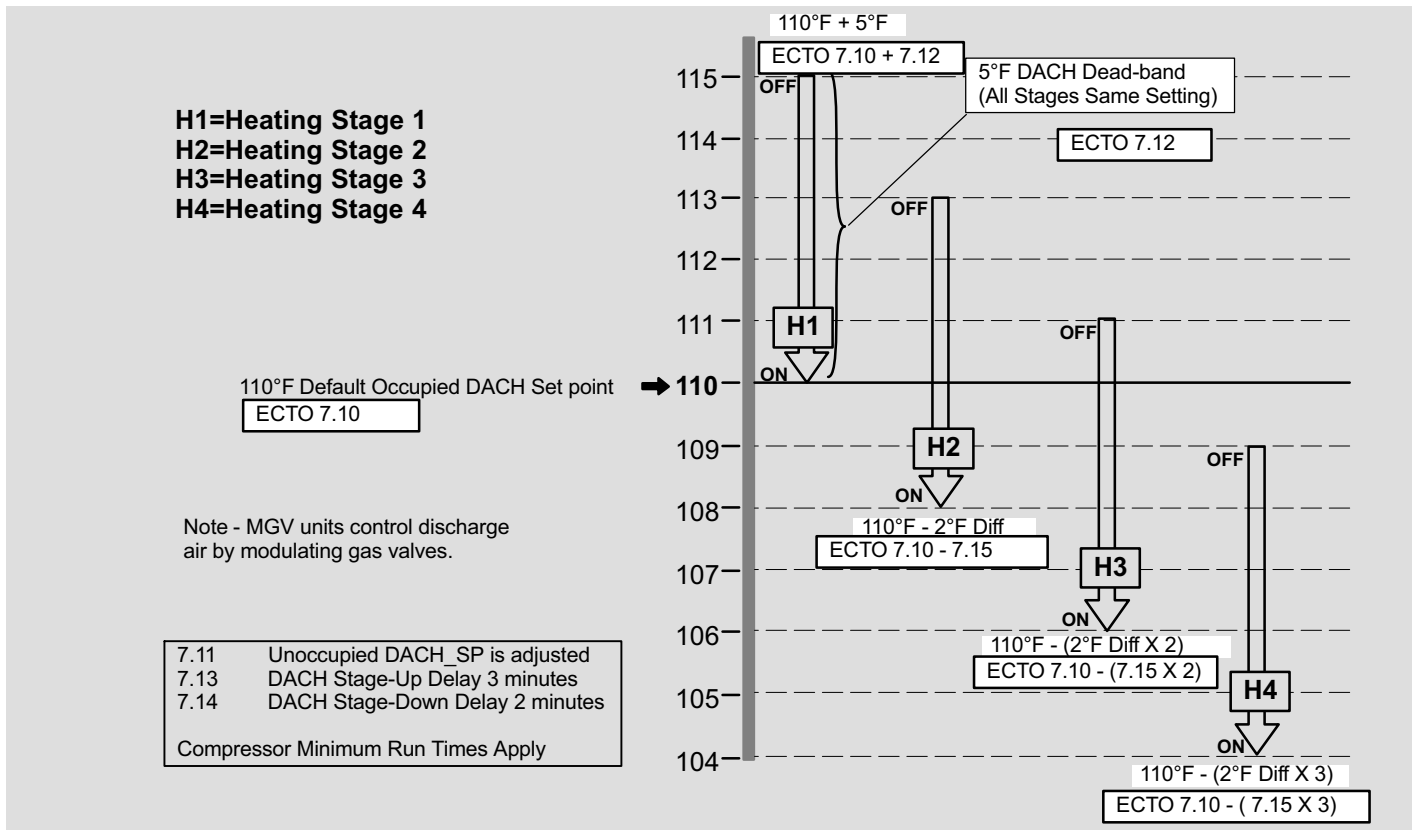

Figure 23. Discharge Air Control Heating (DACH) Stages - Default Values Shown

10.6. Outdoor Air Reset

The DACH set point can be automatically reset when outdoor air temperature becomes warmer.

For outdoor air based DACH set point reset, the discharge air control heating set point starts to decrease when the outdoor air temperature (OAT) rises to the DACH_OAT_RS_SP (ECTO 8.12) (default 40°F). The reset set point will continue to decrease at the rate equal to the DACH_OAT_RS_Adjustment_Band (ECTO 8.14) divided by the DACH_OAT_RS_Proportional_Band (ECTO 8.13). See the following example:

EXAMPLE: The application calls for the discharge air control heating occupied set point (DACC_OCP_SP) (ECTO 7.10) to be 110°F when OAT is 40°F or lower. When the OAT rises above 40°F, the set point needs to decrease proportionately with the OAT increase (maximum set point increase of 10°F). The 10°F OAT decrease is called the DACH_OAT_RS_Proportional_Band and the set point decrease of 10°F is called the DACC_OAT_RS_Adjustment_Band. See figure 24.

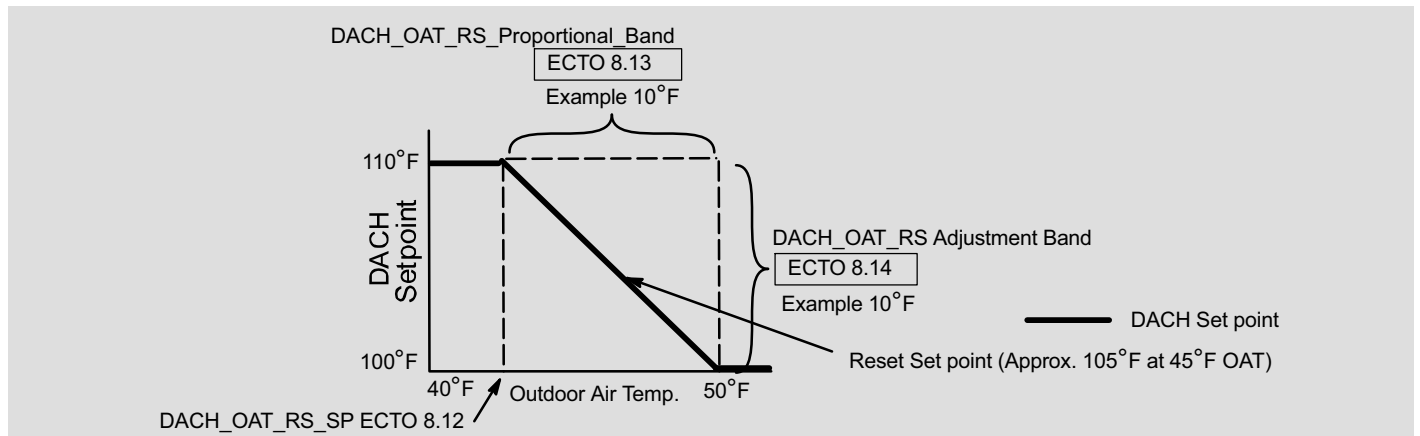

Figure 24. Outdoor Air Reset Example

To use example values, set the following parameters:

- ECTO 8.12 – DACH OAT RS SP – Set to 40°F
- ECTO 8.13 – DACH OAT RS Proportional Band – Set to 10°F
- ECTO 8.14 – DACH OAT RS Adjustment Band -- Set to 10°F (this setting enables DACH outdoor air reset).

10.7. Return Air Reset

The DACC set point can be automatically reset when return air temperature becomes warmer.

For return air based DACH set point reset, the discharge air control heating set point starts to decrease when the return air temperature (RAT) rises to the DACH_RAT_RS_SP (ECTO 8.09) (default 70°F). The reset set point will continue to decrease at the rate equal to the DACH_RAT_RS_Adjustment_Band (ECTO 8.11) divided by the DACH_RAT_RS_Proportional_Band (ECTO 8.10). See the following example:

EXAMPLE: The application calls for the discharge air control heating occupied set point (DACH_OCP_SP) (ECTO 7.10) to be 110°F when RAT is 70°F or lower. When the RAT increases above 70°F, the set point needs to decrease proportionately with the RAT increase (maximum set point increase of 10°F). The 10°F RAT difference is called the DACH_RAT_RS_Proportional_Band and the set point increase of 10°F is called the DACC_RAT_RS_Adjustment_Band. See figure 25.

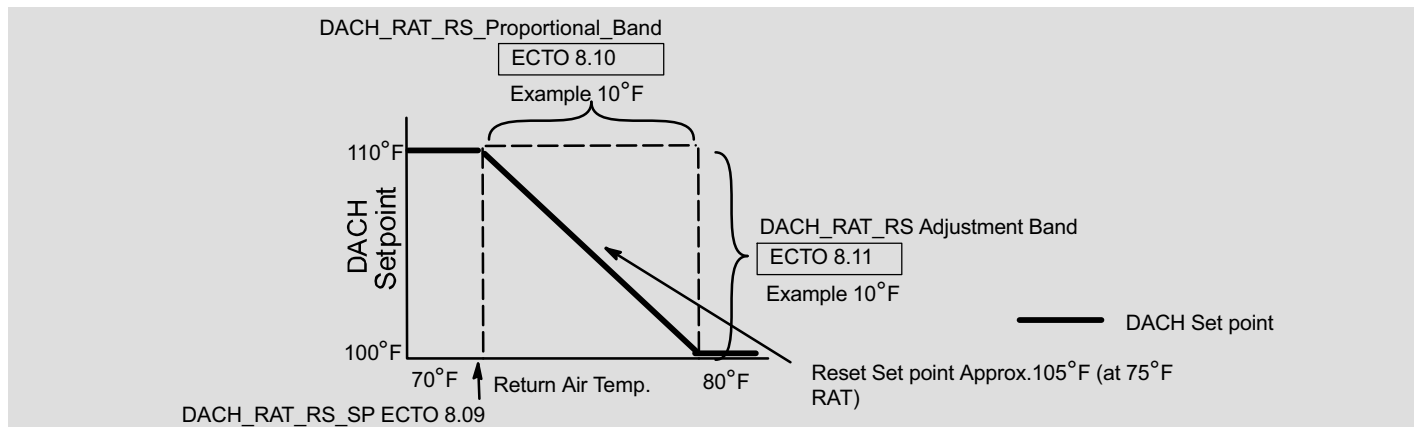

Figure 25. Return Air Reset Example

To use example values, set the following parameters:

- ECTO 8.09 – DACH_RAT_RS_SP – Set to 70°F
- ECTO 8.10 – DACH_RAT_RS_Proportional_Band – Set to 10°F
- ECTO 8.11 – DACH_RAT_RS_Adjustment_Band - Set to 10°F (this setting enables DACH return air reset).

10.8. Discharge Air Control Heating Total Reset Limit

ECTO 8.08 (default=10) defines the total DACH set point reset limit. This total limit is the sum of both return and outdoor DACH resets. This parameter limits total DACH_SP adjustment band and overrides the adjustment bands for RAT and OAT (ECTO 8.11 & 8.14) if necessary.

Table 32. Discharge Air Heating ECTO Parameters Summary

Control Parameter		Control Value			Units	Description																																										
No.	Name	Min.	Default	Max																																												
5.09	HT_Staging	0	2	2	Option	Heating staging options: 0- No heating operation. 1- Discharge air control with up to 4 stages. 2- Thermostat operation.																																										
6.01	System_Mode	0	0	12	Option	System mode of operation. <table border="1"> <thead> <tr> <th>Control Value</th> <th>System Mode</th> <th>Backup Mode</th> </tr> </thead> <tbody> <tr><td>0</td><td>Local Thermostat</td><td>None</td></tr> <tr><td>1</td><td>Zone Sensor</td><td>None</td></tr> <tr><td>2</td><td>Zone Sensor</td><td>Local Thermostat</td></tr> <tr><td>3</td><td>Zone Sensor</td><td>Return Air Sensor</td></tr> <tr><td>4</td><td>Remote Demand</td><td>None</td></tr> <tr><td>5</td><td>Remote Demand</td><td>Local Thermostat</td></tr> <tr><td>6</td><td>Remote Demand</td><td>Return Air Sensor</td></tr> <tr><td>7</td><td>Remote Demand</td><td>Zone Sensor</td></tr> <tr><td>8</td><td>Future Use</td><td>None</td></tr> <tr><td>9</td><td>Future Use</td><td>Local Thermostat</td></tr> <tr><td>10</td><td>Future Use</td><td>Return Air Sensor</td></tr> <tr><td>11</td><td>Future Use</td><td>Zone Sensor</td></tr> <tr><td>12</td><td>A138 4-Stg. Tstat Interface</td><td>None</td></tr> </tbody> </table>	Control Value	System Mode	Backup Mode	0	Local Thermostat	None	1	Zone Sensor	None	2	Zone Sensor	Local Thermostat	3	Zone Sensor	Return Air Sensor	4	Remote Demand	None	5	Remote Demand	Local Thermostat	6	Remote Demand	Return Air Sensor	7	Remote Demand	Zone Sensor	8	Future Use	None	9	Future Use	Local Thermostat	10	Future Use	Return Air Sensor	11	Future Use	Zone Sensor	12	A138 4-Stg. Tstat Interface	None
Control Value	System Mode	Backup Mode																																														
0	Local Thermostat	None																																														
1	Zone Sensor	None																																														
2	Zone Sensor	Local Thermostat																																														
3	Zone Sensor	Return Air Sensor																																														
4	Remote Demand	None																																														
5	Remote Demand	Local Thermostat																																														
6	Remote Demand	Return Air Sensor																																														
7	Remote Demand	Zone Sensor																																														
8	Future Use	None																																														
9	Future Use	Local Thermostat																																														
10	Future Use	Return Air Sensor																																														
11	Future Use	Zone Sensor																																														
12	A138 4-Stg. Tstat Interface	None																																														
7.10	DACH_OCP_SP	36 140	80 110	124 80	Counts X:DegF	Discharge Air Control Heating set point during occupied period.																																										
7.11	DACH_UnOCP_SP	36 140	95 100	124 80	Counts X:DegF	Discharge Air Control Heating set point during unoccupied period.																																										
7.12	DACH_Stg_DB	7 5	7 5	30 20	Counts V:DegF	Discharge Air Control Heating dead-band.																																										
7.13	DACH_&_FAH_StgUp_Delay	0 0	45 180	225 900	Counts B: Sec.	Discharge Air Control Heating and Fresh Air Heating stage-up time delay.																																										
7.14	DACH_&_FAH_StgDn_Delay	0 0	30 120	150 600	Counts B: Sec.	Discharge Air Control Heating and Fresh Air Heating stage-down time delay.																																										
7.15	DACH_Stg_Diff	3 2	3 2	30 20	Counts V:DegF	Discharge Air Control Heating stage differential																																										
8.08	DACH_RS_Limit	7 5	15 10	29 20	Counts V:DegF	Discharge Air Control Heating reset limit. This limits the total DACH reset allowed.																																										
8.09	DACH_RAT_RS_SP	124 80	139 70	169 50	Counts X:DegF	Discharge Air Control Heating return air heating reset set point.																																										
8.10	DACH_RAT_RS_Proportional_Band	1 1	15 10	44 30	Counts V:DegF	Discharge Air Control Heating return air heating reset proportional band.																																										
8.11	DACH_RAT_RS_Adjust_Band	0 0	0 0	44 30	Counts V:DegF	Discharge Air Control Heating return reset adjustment band. 0 value disables return air heating reset.																																										
8.12	DACH_OAT_RS_SP	113 60	144 40	255 -31	Counts Y:DegF	Discharge Air Control Heating outdoor temperature reset set point.																																										
8.13	DACH_OAT_RS_Proportional_Band	1 1	31 20	94 60	Counts O:DegF	Discharge Air Control Heating temperature reset proportional band.																																										
8.14	DACH_OAT_RS_Adjust_Band	0 0	0 0	47 30	Counts O:DegF	Discharge Air Control Heating outdoor temperature reset adjustment band. 0 disables outdoor temperature heating reset																																										

11. Third-Party Zoning

The M2 has many features which allow easy interface with third-party VAV or bypass damper changeover zoning systems. See Figure 26 for a VAV unit wiring summary and figure 27 for a CAV unit w/CAVB wiring summary.

In addition to providing VFD control (VAV units) and bypass damper control (CAV units), the M2 provides discharge air control for cooling and/or heating. More options are available which control single-stage, two-stage, or modulating power exhaust fans.

Only 4 digital inputs are required to control the rooftop unit for third-party zoning applications: G (blower enable), OCP (occupied), Y1 (enables discharge cooling) and W1 (enables discharge heating).

11.1. Air Delivery Operation

When a G signal is energized, the M2 will control a VFD or bypass damper to hold a constant supply duct static pressure. The M2 uses a pressure sensor input and a PID control loop to maintain duct static pressure. For increased flexibility, the M2 has separate adjustable static pressure set points for ventilation, cooling, heating and smoke alarms.

11.2. Occupied /Unoccupied Operation

When the OCP signal is energized, the M2 will adjust the fresh air damper to a fixed minimum position or a modulating position (based on a CO₂ or outdoor air control sensor). Also during morning warm-up/cool-down the M2 will keep the damper closed based on the settings selected.

11.3. Cooling Operation

When a Y1 signal is energized the M2 will control up to 4 stages of cooling (depending RTU size) to automatically maintain a constant discharge air cooling temperature. The M2 also has advanced discharge air cooling reset options based on return air temperature and/or outside air temperature.

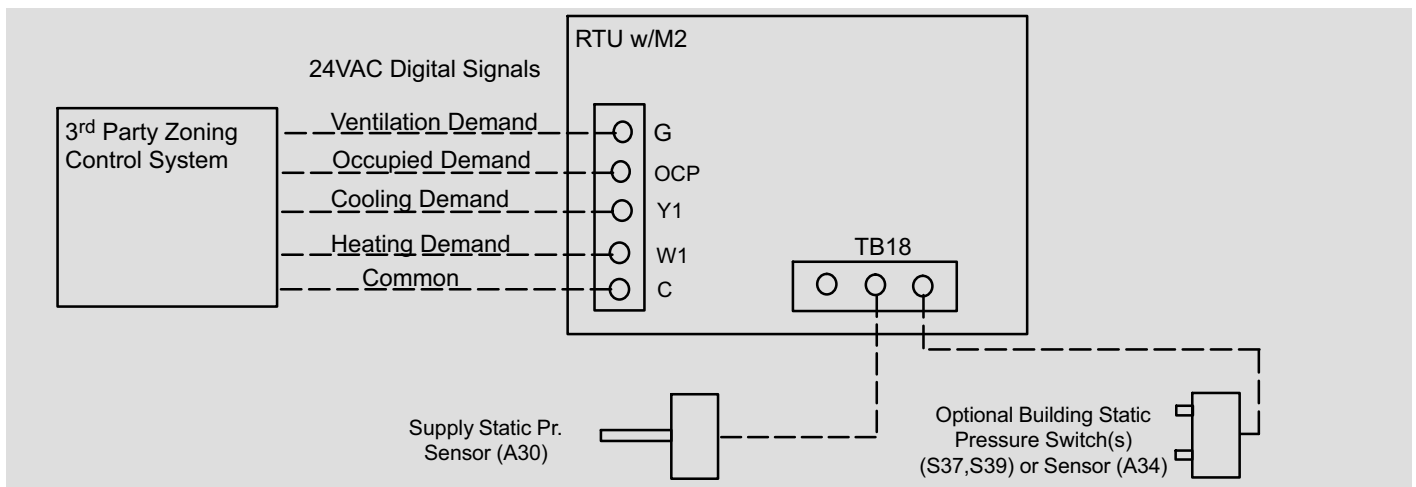

Figure 26. Field Wiring Summary for VAV Unit with Supply Air VFD

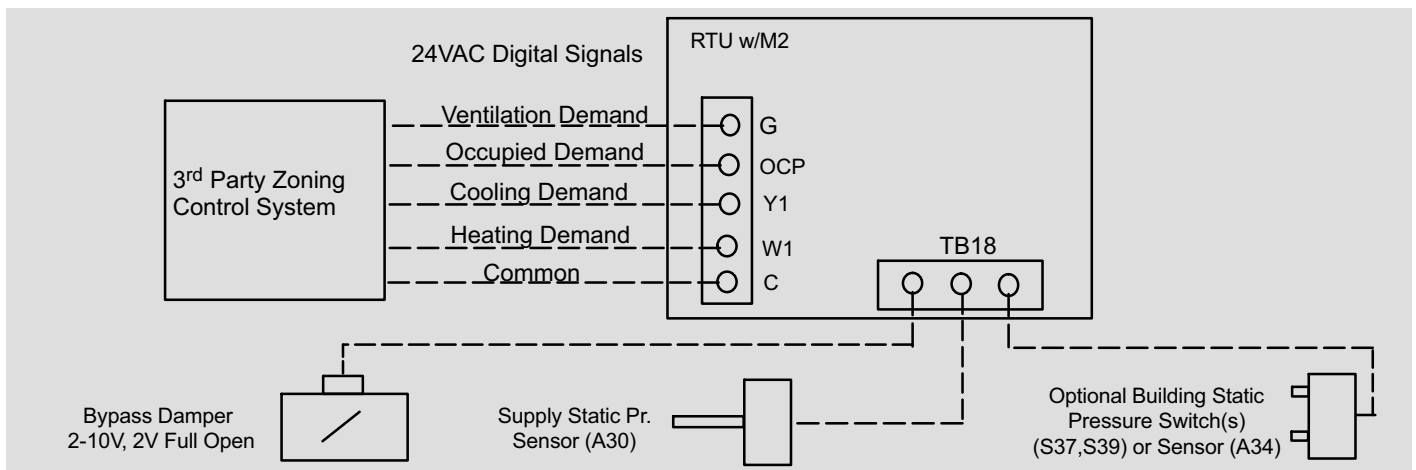

Figure 27. Field Wiring Summary for CAV Unit with Bypass Damper

11.4. DACC Outdoor Air Reset

The outside air reset saves energy by gradually increasing the discharge air set point as the outside air temperature decreases.

11.5. DACC Return Air Reset

The return air reset reduces the possibility of over-cooling by gradually increasing the discharge air set point as the return air temperature decreases. Over-cooling may occur if the zoning system is misapplied, has an abnormal condition, or a dominant zone.

11.6. Heating Operation

When a W1 signal is energized, the M2 will control up to 4 stages of heating (depending on RTU size) to automatically maintain a constant discharge air heating temperature. The M2 also has advanced discharge air heating reset options based on return air temperature and/or outside air temperature.

11.7. DACH Outdoor Air Reset

The outside air reset saves energy by gradually decreasing the discharge air set point as the outside air temperature increases.

11.8. DACH Return Air Reset

The return air reset reduces the possibility of overheating by gradually decreasing the discharge air set point as the return air temperature increases. Overheating may occur if the zoning system is miss-applied, has an abnormal condition, or dominant zone.

11.9. Power Exhaust Operation

The M2 has many power exhaust fan control options that include single-stage, two-stage and modulating control depending on how the unit is equipped. The stage control options can be triggered based on fresh air damper position, pressure switches or pressure analog sensor. The modulating control for units with VFD powered exhaust fans are typically modulated to maintain building static pressure, but can also be staged. See Power Exhaust Section.

11.10. VAV and CAVB Analog Outputs

Refer to the Supply Air Delivery section and the optional Power Exhaust Fan section.

11.10.1. VFD Control

The M2 is only compatible with the factory-installed variable frequency drives (VFD) provided in VAV units. The VFD is used to control the supply blower and exhaust fan(s). The analog control for the VFDs is 0-10Vdc. This manual uses percent (%) to indicate blower and fan speeds. For example, 50% blower speed is equal to 30Hz and 5Vdc.

Speed %	Motor Frequency (Hz)	VFD Control Voltage (VDC)	Speed %	Motor Frequency (Hz)	VFD Control Voltage (VDC)
0	0	0	60	36	6
10	6	1	70	42	7
20	12	2	80	48	8
30	18	3	90	54	9
40	24	4	100	60	10
50	30	5			

11.10.2. Supply Bypass Damper Control

The M2 is only compatible with bypass damper actuators specified in the Engineering Handbook. The actuators control the supply air volume for constant air volume units equipped with a bypass damper (CAVB) in zoning applications. The analog control for the actuator is 2-10Vdc. Dampers are closed at 10Vdc and fully open at 2Vdc. This manual uses percent (%) to indicate bypass damper position. For example, 70% bypass damper position is equal to 4.4Vdc.

Bypass Damper Position (%)	Control Voltage (VDC)	Bypass Damper Position (%)	Control Voltage (VDC)	Bypass Damper Position (%)	Control Voltage (VDC)	Bypass Damper Position (%)	Control Voltage (VDC)
0 (closed)	10	30	7.6	60	5.2	90	2.8
10	9.2	40	6.8	70	4.4	100	2.0
20	8.4	50	6.0	80	3.6		

Table 33. Air Delivery Setup for CAV w/Bypass for Changeover Zoning Applications

ECTO No.	Name	Default Setting	Setting Required	Description
0.01	Supply_VAV_Control_Mode	0	1	Sets PID control of bypass damper for all modes, ventilation, cooling, heating and smoke alarms.
0.10	PID_P_Constant	17	Select (Recommend default)	PID Proportional constant
0.11	PID_I_Constant	12	Select (Recommend default)	PID Integral constant
0.12	PID_D_Constant	0	Select (Recommend default)	PID derivative constant
0.13	CAVB_SMK_SP	1.00"w.c.	Select 0-5"w.c.	Supply static pressure set point during smoke alarm. Typically 1 to 1.5"w.c.
0.14	CAVB_Vent_SP	1.00"w.c.	Select 0-5"w.c.	Supply static pressure set point during ventilation only. Typically 1 to 1.5"w.c.
0.15	CAVB_HT_SP	1.00"w.c.	Select 0-5"w.c.	Supply static pressure set point during heating. Typically 1 to 1.5"w.c.
0.16	CAVB_CL_SP	1.00"w.c.	Select 0-5"w.c.	Supply static pressure set point during cooling. Typically 1 to 1.5"w.c.
0.17	CAVB_Min_Output_for SMK_Vent_CL	20%	Select 20-100% (Recommend default)	Minimum output to bypass damper during smoke alarm, ventilation only and cooling. Sets minimum air delivered. Bypass damper motor is set to 10 to 2 volts with 10 v being closed.
0.18	CAVB_Min_Output_for HT	20%	Select 20-100% (Recommend default)	Minimum output to bypass damper during heating. Sets minimum delivered.
0.19	CAVB_Max_Output	100%	Select 20-100% (Recommend default)	Maximum output to bypass damper for all modes. Sets the maximum air delivered.
0.20	CAVB_ManRS	52%	Select 20-100% (Recommend default)	Bypass damper manual reset value output. Output when blower is off.
0.21	Supply_Static_Shutdown_SP	2.0"w.c.	Select 0-5.0"w.c.	Supply static shutdown set point. Unit will shutdown for ECTO 5.02 minutes if duct pressure exceeds this value for 20 seconds
0.22	Supply_Static_Lockout_Counts	3	Select 0-5 counts (Recommend default)	The number of occurrences before permanent lockout. Counter resets when M2 resets. A value of 0 will disable lockout.
Air Delivery Setup For VAV Zoning Applications				
0.01	Supply_VAV_Control_Mode	0	63	Sets PID control of VFD all modes, ventilation, cooling, heating and smoke alarms.
0.02	VAV_Press_SMK_SP	1.00"w.c.	Select 0-5 "w.c.	VAV supply static pressure set point during smoke detection.
0.03	VAV_Press_Vent_SP	1.00"w.c.	Select 0-5 "w.c.	VAV supply static pressure set point during ventilation.
0.04	VAV_Press_HT_SP	1.00"w.c.	Select 0-5 "w.c.	VAV supply static pressure set point during heating.
0.05	VAV_Press_CL_SP	1.00"w.c.	Select 0-5 "w.c.	VAV supply static pressure set point during cooling.
0.06	VAV_Min_Output_for CL_VT_SMK.	50%	Select 30-100%	Supply minimum speed for cooling, ventilation or smoke. If minimum is >= manual reset (ECTO 0.09), then manual reset used is shifted to (ECTO 0.07 + ECTO 0.08) / 2
0.07	VAV_Min_Output_for HT	50%	Select 30-100%	Supply minimum speed for heating. If minimum is >= manual reset (ECTO 0.09), then manual reset used is shifted to (ECTO 0.06 + ECTO 0.08) / 2
0.08	VAV_Max_Output	100%	Select 0-100% 0-100%	Supply maximum output.
0.09	VAV_PID_ManRS	60%	Select 0-100% (Recommend default)	Supply PID manual reset value.

table continued on next page

ECTO No.	Name	Default Setting	Setting Required	Description
Air Delivery Setup For VAV Zoning Applications - continued				
ECTO No.	Name	Default Setting	Setting Required	Description
0.10	PID_P_Constant	17	Select (Recommend default)	PID Proportional constant
0.11	PID_I_Constant	12	Select (Recommend default)	PID Integral constant
0.12	PID_D_Constant	0	Select (Recommend default)	PID derivative constant
0.21	Static_Shutdown_SP	2.0"w.c.	Select 0-5"w.c.	Supply static shutdown set point. Unit will shutdown for ECTO 5.02 minutes if duct pressure exceeds this value for 20 seconds.
0.22	Static_Lock-out_Counts	3	Select 0-3 (Recommend default)	The number of occurrences before permanent lockout. Counter resets when M2 resets. A value of 0 will disable lockout.
Discharge Air Control Setup for Cooling				
5.04	CL_Stg_Option	2	4	Option 4 sets control to operate discharge air control cooling when Y1 is energized.
7.16	DACC_OCP_SP	55F	Select 40-80F	Discharge Air Control Cooling set point during occupied period.
7.17	DACC_UnOCP_SP	65F	Select 40-80F	Discharge Air Control Cooling set point during unoccupied period.
7.18	DACC_Stg_DB	5F	Select 5-20F	Discharge Air Control Cooling stage dead-band.
7.19	DACC_&_FAC_StgUp_Delay	180Sec.	Select 0-900 Sec (Recommend default)	Discharge Air Control Cooling and Fresh Air Cooling stage-up delay.
7.20	DACC_&_FAC_StgDn_Delay	120Sec.	Select 0-600Sec. (Recommend default)	Discharge Air Control Cooling and Fresh Air Cooling stage-down time delay.
7.21	DACC_Stg_Dif	2F	Select 2-20F (Recommend default)	Discharge Air Cooling stage differential.
8.01	DACC_RS_Limit	10F	Select 5-20F (Recommend default)	Discharge Air Control Cooling total reset limit. This limits the total DACC reset allowed.
8.02	DACC_RAT_RS_SP	70F	Select 50-80F	Discharge Air Control Cooling return air reset set point
8.03	DACC_RAT_RS_Proportional_Band	10F	Select 1-30F	Discharge Air Control Cooling return air reset proportional band.
8.04	DACC_RAT_RS_Adjust_Band	0F (disabled)	Select 0-30F	Discharge Air Control Cooling return air reset adjustment band. 0 disables return air cooling reset.
8.05	DACC_OAT_RS_SP	80F	Select 40-100F	Discharge Air Control Cooling outdoor air temperature cooling reset set point.
8.06	DACC_OAT_RS_Proportional_Band	20F	Select 1-60F	Discharge Air Control Cooling outdoor ambient temperature cooling proportional band.
8.07	DACC_OAT_RS_Adjust_Band	0F (disabled)	Select 0-30F	Discharge Air Control Cooling outdoor temperature ambient cooling adjustment reset band. 0 disables outdoor air cooling reset

table continued on next page

ECTO No.	Name	Default Setting	Setting Required	Description
Discharge Air Control Setup for Heating				
5.09	HT_Staging	2	1	Option 1 sets control to operate discharge air control heating when W1 is energized.
7.10	DACH_OCP_SP	110	Select 80-140F	Discharge Air Control Heating set point during occupied period.
7.11	DACH_UnOCP_SP	100	Select 80-140F	Discharge Air Control Heating set point during unoccupied period.
7.12	DACH_Stg_DB	5F	Select 5-20F (Recommend default)	Discharge Air Control Heating dead-band.
7.13	DACH_&_FAC_StgUp_Delay	180 Sec.	Select 0-900Sec. (Recommend default)	Discharge Air Control Heating and Fresh Air Heating stage-up time delay.
Discharge Air Control Setup for Heating				
ECTO No.	Name	Default Setting	Setting Required	Description
7.14	DACH_&_FAC_SgDn_Delay	120 Sec.	Select 0-600Sec. (Recommend default)	Discharge Air Control Heating and Fresh Air Heating stage-down time delay.
7.15	DACH_Stg_Dif	2F	Select 2-20F (Recommend default)	Discharge Air Control Heating stage differential
8.08	DACH_RS_Limit	10F	Select 5-20F. (Recommend default)	Discharge Air Control Heating reset limit. This limits the total DACH reset allowed.
8.09	DACH_RAT_RS_SP	70F	Select 50-80F.	Discharge Air Control Heating return air heating reset set point.
8.10	DACH_RAT_RS_Proportional_Band.	10F	Select 1-30F.	Discharge Air Control Heating return air heating reset proportional band.
8.11	DACH_RAT_RS_Adjust_Band	0F (disabled)	Select 0-30F.	Discharge Air Control Heating return reset adjustment band. 0 value disables return air heating reset.
8.12	DACH_OAT_RS_SP	40F	Select -31-60F.	Discharge Air Control Heating outdoor temperature reset set point.
8.13	DACH_OAT_RS_Proportional_Band.	20F	Select 1-60F.	Discharge Air Control Heating temperature reset proportional band.
8.14	DACH_OAT_RS_Adjust_Band	0F (disabled)	Select 0-30F.	Discharge Air Control Heating outdoor temperature reset adjustment band. 0 disables outdoor temperature heating reset

table continued on next page

ECTO No.	Name	Default Setting	Setting Required	Description																																																																																														
Power Exhaust Setup																																																																																																		
8.16	Exh_Fan_Control	0	Select depending on type of exhaust fan.	<p>Single stage (controlled by A55_P265-2 output)</p> <table border="1"> <thead> <tr> <th>Mode</th> <th>Enable</th> <th>Input</th> </tr> </thead> <tbody> <tr><td>0-</td><td>Blower</td><td>D_POS</td></tr> <tr><td>1-</td><td>Always</td><td>A133_P149-1</td></tr> <tr><td>2-</td><td>OCP</td><td>A133_P194-1</td></tr> <tr><td>3-</td><td>Blower</td><td>A133_P194-1</td></tr> <tr><td>4-</td><td>Always</td><td>A133_P194-7</td></tr> <tr><td>5-</td><td>Occupied</td><td>A133_P194-7</td></tr> <tr><td>6-</td><td>Blower</td><td>A133_P194-7</td></tr> <tr><td>7-</td><td>A133_P194-1</td><td>A133_P194-7</td></tr> </tbody> </table> <p>Two stage exhaust fan (controlled by A55_P265-2 and A133_P194-5 outputs)</p> <table border="1"> <thead> <tr> <th>Mode</th> <th>Enable</th> <th>Input 1</th> <th>Input 2</th> </tr> </thead> <tbody> <tr><td>8-</td><td>Blower</td><td>D_POS</td><td>D_POS</td></tr> <tr><td>9-</td><td>Always</td><td>A133_P194-1</td><td>A133_P194-2</td></tr> <tr><td>10-</td><td>Occupied</td><td>A133_P194-1</td><td>A133_P194-2</td></tr> <tr><td>11-</td><td>Blower</td><td>A133_P194-1</td><td>A133_P194-2</td></tr> <tr><td>12-</td><td>Always</td><td>A133_P194-7</td><td>A133_P194-7</td></tr> <tr><td>13-</td><td>Occupied</td><td>A133_P194-7</td><td>A133_P194-7</td></tr> <tr><td>14-</td><td>Blower</td><td>A133_P194-7</td><td>A133_P194-7</td></tr> <tr><td>15-</td><td>A133_P194-1</td><td>A133_P194-7</td><td>A133_P194-7</td></tr> </tbody> </table> <p>For option 9-15, Stage 2 will not turn on until ECTO 8.25 seconds after stage 1. Stage 1 won't turn off until ECTO 8.22 seconds after stage turns off.</p> <p>VFD (PID) controlled exhaust fan with on/off cycling at minimum speed (cycled by A55_P265-2 and speed controlled by VFD)</p> <table border="1"> <thead> <tr> <th>Mode</th> <th>Enable</th> <th>Analog Input</th> </tr> </thead> <tbody> <tr><td>16</td><td>Always</td><td>A133_P194-7</td></tr> <tr><td>17-</td><td>Occupied</td><td>A133_P194-7</td></tr> <tr><td>18-</td><td>Blower</td><td>A133_P194-7</td></tr> <tr><td>19-</td><td>A133_P194-1</td><td>A133_P194-7</td></tr> </tbody> </table> <p>Min. speed cycling: On at 10% over set point. Off after 30 seconds at minimum speed. Minimum 30 seconds off.</p> <p>VFD (PID) controlled exhaust fan (always on when enabled) (cycled by A55_P265-2 and speed controlled by VFD)</p> <table border="1"> <thead> <tr> <th>Mode</th> <th>Enable</th> <th>Analog Input</th> </tr> </thead> <tbody> <tr><td>20</td><td>Always</td><td>A133_P194-7</td></tr> <tr><td>21</td><td>Occupied</td><td>A133_P194-7</td></tr> <tr><td>22</td><td>Blower</td><td>A133_P194-7</td></tr> <tr><td>23</td><td>A133_P194-1</td><td>A133_P194-7</td></tr> </tbody> </table> <p>Always on at least minimum speed when enabled.</p>	Mode	Enable	Input	0-	Blower	D_POS	1-	Always	A133_P149-1	2-	OCP	A133_P194-1	3-	Blower	A133_P194-1	4-	Always	A133_P194-7	5-	Occupied	A133_P194-7	6-	Blower	A133_P194-7	7-	A133_P194-1	A133_P194-7	Mode	Enable	Input 1	Input 2	8-	Blower	D_POS	D_POS	9-	Always	A133_P194-1	A133_P194-2	10-	Occupied	A133_P194-1	A133_P194-2	11-	Blower	A133_P194-1	A133_P194-2	12-	Always	A133_P194-7	A133_P194-7	13-	Occupied	A133_P194-7	A133_P194-7	14-	Blower	A133_P194-7	A133_P194-7	15-	A133_P194-1	A133_P194-7	A133_P194-7	Mode	Enable	Analog Input	16	Always	A133_P194-7	17-	Occupied	A133_P194-7	18-	Blower	A133_P194-7	19-	A133_P194-1	A133_P194-7	Mode	Enable	Analog Input	20	Always	A133_P194-7	21	Occupied	A133_P194-7	22	Blower	A133_P194-7	23	A133_P194-1	A133_P194-7	<div style="border: 1px solid black; padding: 5px; margin-bottom: 10px;">Use ECTO 8.20 and 8.21 for set point and dead-band. Use ECTO 8.17 for 0-10VDC stage 1 output if A133 (VAV) present.</div> <div style="border: 1px solid black; padding: 5px; margin-bottom: 10px;">Use ECTO 8.20-8.25 for stage set points, dead-bands and stage delays. Use ECTO 8.17 for 0-10VDC stage 1 output. Use ECTO 8.18 for 0-10VDC stage 2 output.</div> <div style="border: 1px solid black; padding: 5px; margin-bottom: 10px;">Use ECTO 8.19-8.25 for set point and PID constants.</div> <div style="border: 1px solid black; padding: 5px;">Use ECTO 8.20-8.25 for set point and PID constants.</div>
				Mode	Enable	Input																																																																																												
				0-	Blower	D_POS																																																																																												
				1-	Always	A133_P149-1																																																																																												
				2-	OCP	A133_P194-1																																																																																												
				3-	Blower	A133_P194-1																																																																																												
				4-	Always	A133_P194-7																																																																																												
				5-	Occupied	A133_P194-7																																																																																												
				6-	Blower	A133_P194-7																																																																																												
				7-	A133_P194-1	A133_P194-7																																																																																												
Mode	Enable	Input 1	Input 2																																																																																															
8-	Blower	D_POS	D_POS																																																																																															
9-	Always	A133_P194-1	A133_P194-2																																																																																															
10-	Occupied	A133_P194-1	A133_P194-2																																																																																															
11-	Blower	A133_P194-1	A133_P194-2																																																																																															
12-	Always	A133_P194-7	A133_P194-7																																																																																															
13-	Occupied	A133_P194-7	A133_P194-7																																																																																															
14-	Blower	A133_P194-7	A133_P194-7																																																																																															
15-	A133_P194-1	A133_P194-7	A133_P194-7																																																																																															
Mode	Enable	Analog Input																																																																																																
16	Always	A133_P194-7																																																																																																
17-	Occupied	A133_P194-7																																																																																																
18-	Blower	A133_P194-7																																																																																																
19-	A133_P194-1	A133_P194-7																																																																																																
Mode	Enable	Analog Input																																																																																																
20	Always	A133_P194-7																																																																																																
21	Occupied	A133_P194-7																																																																																																
22	Blower	A133_P194-7																																																																																																
23	A133_P194-1	A133_P194-7																																																																																																
8.17	Exh_Fan_Stg_1_SP	50%	Select 0-100%	Speed set point for stage 1 exhaust fan when using a VFD for controlling exhaust fan in staged mode.																																																																																														
8.18	Exh_Fan_Stg_2_SP	100%	Select 0-100%	Speed set point for stage 2 exhaust fan when using a VFD for controlling exhaust fan in staged mode.																																																																																														
8.19	Exh_Fan_SP_for_SMK	-0.3"w.c.	Select -0.5 – 0.5"w.c.	Exhaust fan smoke mode set point for PID option control																																																																																														
	Staged_SMK	50%	0-100%	Staged set point for during smoke alarm. Value used depends on smoke mode (ECTO 5.01)																																																																																														
8.20	Exh_Fan_SP	-0.3"w.c.	Select -0.5 – 0.5"w.c.	Exhaust fan set point for PID option control																																																																																														
	Stage_1_SP	50%	0-100%	Stage 1 set point																																																																																														
8.21	Exh_Fan_Min.	10%	Select 0-100%	Exhaust fan minimum speed																																																																																														
	Staged_1_DB	0.04	0-1.0"w.c.	Staged 1 dead-band.																																																																																														
8.22	Exh_Fan_ManRS	10%	Select 0-100%	Exhaust fan PID loop manual reset value																																																																																														
	Stg_1_Off_Delay	100 Sec.	0-200 Sec.	Stage 1 off-delay.																																																																																														
8.23	Exh_Fan_PID_P_Constant	20 Counts	Select 0-255Counts	Exhaust fan PID loop proportional constant																																																																																														
	Stg_2_SP	"w.c.	-0.5 – 0.5"w.c.	Staged 2 set point.																																																																																														
8.24	Exh_Fan_PID_I_Constant	64 Counts	Select 0-255 Counts	Exhaust fan PID loop integral constant																																																																																														
	Stg_2_DB	.25"w.c.	0-1.0"w.c.	Staged 2 dead-band.																																																																																														
8.25	Exh_Fan_PID_D_Constant	0 Counts	Select 0-127 Counts	Exhaust fan PID loop derivative constant																																																																																														
	Stg_2_On_Delay	0 Sec.	0-254Sec.	Staged 2 on-delay.																																																																																														

11.11. M2 LonTalk® Module

The optional M2 LonTalk® module allows communication between the Lennox M2 and a LonWorks® network. The module translates input and output variables between the Lennox protocol and the LonTalk protocol. The M2 LonTalk module has been developed to communicate with building automation systems that support the LonMark® Space Comfort Control (SCC) or Discharge Air Control (DAC) functional profiles. A Lennox non-communicating zone sensor or a LonTalk network zone sensor may be used to send the zone temperature to the M2. Use of a LonTalk thermostat to send direct heating and cooling demands is not supported at this time.

NOTE - A qualified systems integrator with adequate training and experience is required to integrate and commission the M2 LonTalk module into a third-party LonTalk building automation system. A LonWorks network configuration software tool such as LonMaker® (or equivalent) is required to commission the LonWorks network. An external interface file (XIF) will be made available upon request.

Refer to the Installation Instructions for the M2 LonTalk module for installation. Refer to the Service Literature for the M2 LonTalk module for data point and programming information.

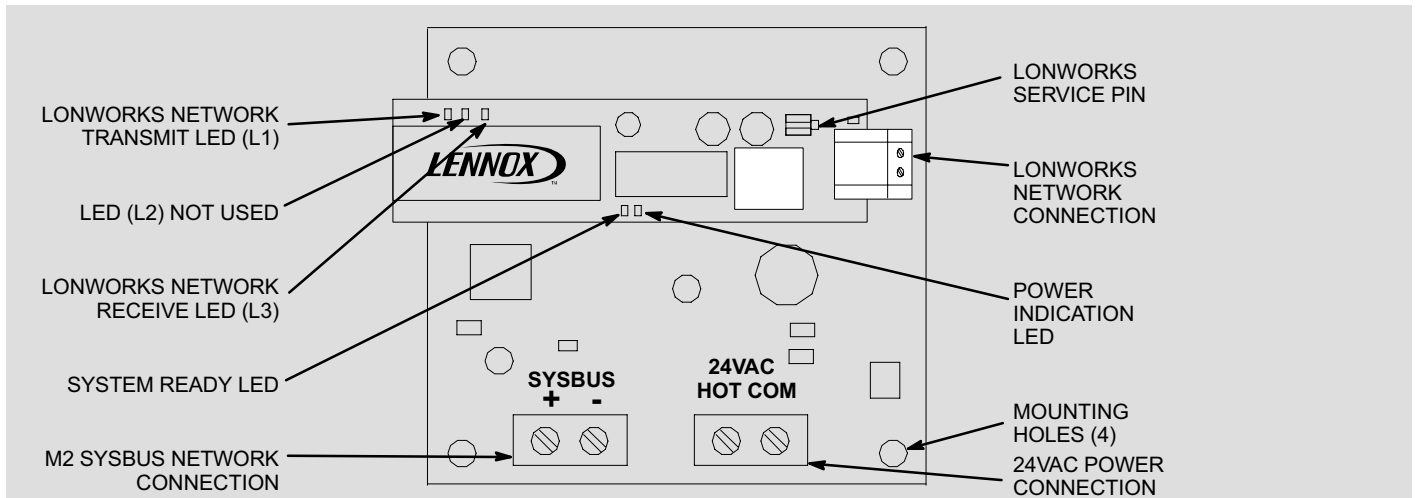

Figure 28. M2 LonTalk Module

12. BACnet®

12.1. M2 BACnet™ Module

The optional M2 BACnet Module allows communication between the Lennox M2 (M2, version 6.00 and higher) and a BACnet MSTP network. The BACnet module conforms to the BACnet application specific controller (B-ASC) device profile. A Lennox non-communicating zone sensor, a BACnet network zone sensor, or a BACnet thermostat may be used to send the zone temperature or thermostat demands to the M2.

NOTE - A qualified systems integrator with adequate training and experience is required to integrate and commission the M2 BACnet into a third-party BACnet Building Automation System. A BACnet network configuration software tool is required to commission the BACnet network.

Refer to the Installation Instructions for the M2 BACnet Module for installation. Refer to the Service Literature for the M2 BACnet Module for data point and programming information.

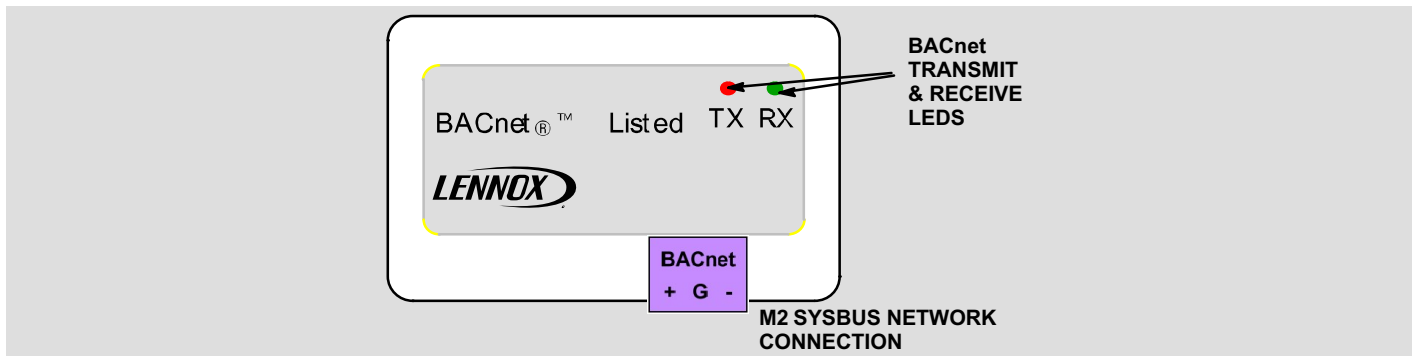

Figure 29. M2 BACnet Module

12.2. Recommendations

1. Set all BACnet devices on an MS/TP network to consecutive MAC addresses, starting at 1, so that there are no gaps between MAC address values.
2. Set Max_Master device property on all devices to match the largest MAC address on the network. Note, this could be larger than existing network to allow for adding devices to the network with out the need to adjust the Max_Master property.
3. Use ReadPropertyMultiple service instead of ReadProperty service when reading multiple analog inputs or values

12.3. Default Settings

device Max_Master = 127
 device Max_Info_Frames = 1
 device Object_Identifier = MAC address
 device Object_Name = "Lennox_M2" + MAC address
 device Location = "US"
 device Description = "Lennox HVAC Controller"
 baud rate = 38.4k

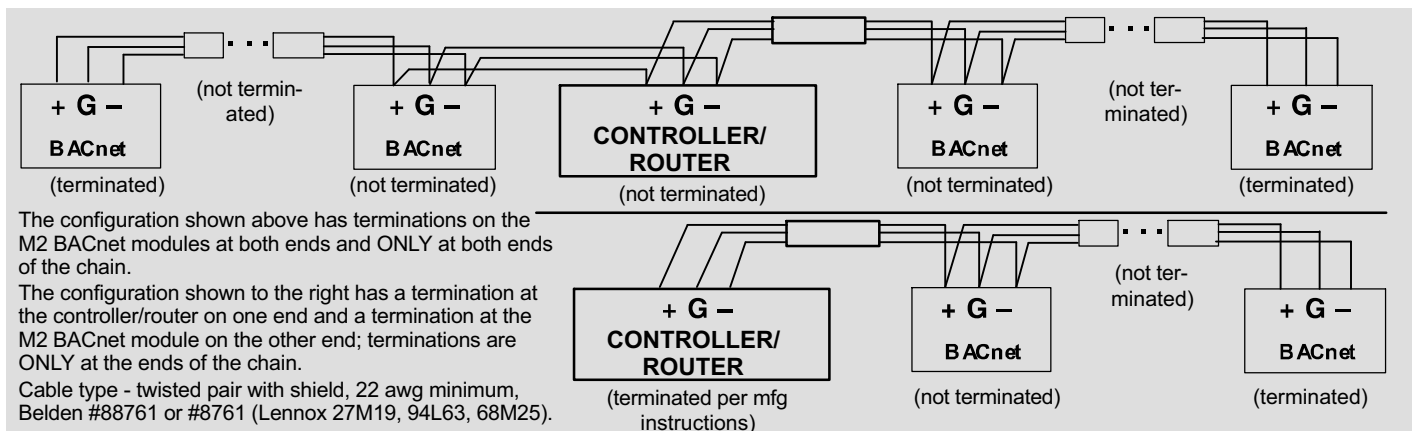

Figure 30. Terminating ends of daisy-chained networks

12.4. Analog Output Objects

Optional Properties Supported: Min_Pres_Value, Max_Pres_Value

Optional Writable Properties: Out_Of_Service

Analog output object's Overridden status flag set if the equivalent set point in the M2 is written to by an Sbus device.

Table 34. Analog Output Objects List

Object ID	Object Name	Units	Min. Value	Max. Value	Valid Values within Range
101	Application Mode Control	None	0	255	0,1,3,6,9,208,209,216,217,218,224-254,255*
102	Outdoor Air Min Pos Control	Percent	0	255	all
103	Occupancy Override Control	None	0	255	all
104	Occupancy Scheduler Control	None	0	255	all
107	Occupancy Sensor Input	None	0	255	all
108	Space Dehumidification Set point	Percent	0	100	all
109	Temperature Set point (abs)	Deg. F	36.25	100	all
110	Temperature Set point Offset	Deg. F	-32	31.75	all
113	Space Temperature Input	Deg. F	36.25	100	all
114	Emergency Override Control	None	0	255	all
115	Compressor Enable Control	None	0	255	all
117	Primary Heat Enable Control	None	0	255	all
119	Auxiliary Heat Enable Control	None	0	255	all
123	Duct Static Set point	In. of water	0	5	all
124	Building Static Set point	In. of water	-0.5	0.5	all
125	Discharge Air Cooling Set point	Deg. F	40	80	-9,40-80*
126	Discharge Air Heating Set point	Deg. F	80	140	-9,80-140*
127	Supply Fan Capacity Input	Percent	33	255	all*
128	Exhaust Fan Capacity Input	Percent	33	255	all
129	Set Economizer Outdoor Air Suitable	None	0	255	all

* see Application Details section for limitations on data ranges.

12.5. Analog Value Objects

Optional Properties Supported: None

Optional Writable Properties: Present_Value

Table 35. Analog Value Objects List

Object ID	Object Name	Units	Min. Value	Max. Value	Valid Values within Range	Note
1	Baud Rate Setting	None	9600	76800	9600, 19200, 38400, 76800	38400 default
130	Heating Occupied Set point	Deg. F	40	95	all	For occupied and unoccupied set points considered separately, the heating set point must be lower than the cooling set point by at least the auto-changeover dead-band value set in M2 ECTO 6.15 (default 3 degF).
131	Cooling Occupied Set point	Deg. F	40	95	all	
132	Heating Unoccupied Set point	Deg. F	40	95	all	
133	Cooling Unoccupied Set point	Deg. F	40	95	all	

12.6. Analog Input Objects

Optional Properties Supported: None

Optional Writable Properties: Out_Of_Service (AI239 - AI252, AI274 - AI285 only)

Table 36. Analog Input Objects List

Object ID	Object Name	Units	Data Range
198	Mac Address	None	0 – 127
199	M2 Address	None	1–31
200*	M2 Version[4]	None	0 – 127
201*	M2 Version[5]	None	0 – 127
202*	M2 Version[6]	None	0 – 127
203*	M2 Version[7]	None	0 – 127
204*	M2 Version[8]	None	0 – 127
205*	M2 Version[9]	None	0 – 127
206*	M2 Version[10]	None	0 – 127
207*	M2 Version[11]	None	0 – 127
231	Unit ID	None	0 – 127
232	Unit Status	None	0 – 255
239	Space Temperature	Deg. F	63.75 – 100.00
240	Discharge Air Temperature	Deg. F	–8.7 – 164.4
241	Effective Occupancy	None	0 – 2
242	Local Outside Air Temperature	Deg. F	–30.6 – 131.6
243	Local Space Temperature	Deg. F	63.75 – 100.00
244	Outside Air Damper	Percent	0 – 100, 255
245	Heat Primary	Percent	0 – 100
246	Heat Secondary	Percent	0 – 100
247	Cool Primary	Percent	0 – 100
248	Economizer Enabled	Percent	0, 1, 255
250	Supply Fan Status	Percent	0 – 100
252	Space Temperature Set Point (Eff)	Deg. F	40.0 – 95.0
253	Current Error	None	0 – 255
254	Error Pointer	None	0 – 83
255	Most recent Error 1	None	1 – 255
256	Most recent Error 2	None	1 – 255
257	Most recent Error 3	None	1 – 255
258	Most recent Error 4	None	1 – 255
259	Most recent Error 5	None	1 – 255
260	Most recent Error 6	None	1 – 255
261	Most recent Error 7	None	1 – 255
262	Most recent Error 8	None	1 – 255
263	Most recent Error 9	None	1 – 255
264	Most recent Error 10	None	1 – 255
274	Space CO2 Sensor (Eff)	Parts-per-million	0 – 2000
275	Space CO2 Sensor (Local)	Parts-per-million	0 – 2000
276	Space Humidity (Eff)	Percent	0 – 100
277	Space Humidity (Local)	Percent	0 – 100
278	Dehumidification Set Point (Eff)	Percent	0 – 100
279	Dehumidification Status	None	0 – 2
281	Return Air Temperature	Deg. F	–8.7 – 164.4
282	Building Static Pressure	Inches of water	–0.5 – 0.5
283	Duct Static Pressure	Inches of water	0 – 5.00
285	Exhaust Fan Status	Percent	0 – 100

* Not recommended for new installations; legacy support only

13. Modulating Gas Valve (MGV)

Units equipped with optional modulating gas valves (MGV) contain two modulating gas valves in addition to two standard gas valves.

13.1. Operation

The M2 will control modulating gas valves to maintain 110°F (default) discharge air during the heating cycle. The left heat section will operate when 25-50% of nameplate heat is needed. Both heat sections will operate when 50-100% of the nameplate heat is needed.

The normally open MGV will allow full heating capacity should the MGV fail.

13.2. Testing

Use the options given under the Prodigy "SERVICE/TEST" menu to run high or low capacity output.

13.3. M2 Output

The M2 0-10VDC output to the MGVs increases to modulate valves further closed during a reduced heating demand. The M2 0-10VDC output to the MGVs decreases to modulate valves further open during a higher heating demand.



14. Load Shedding Options

The M2 may be setup to de-energize half of the mechanical cooling provided by a rooftop unit. A digital input to either the economizer (A55_P297-9) or the (A133) GP1 board is required. This option is set by adjusting ECTO 7.25. See table 37.

Table 37. Adjusting Load Shedding Options

Options	Digital Input (energized for load shedding)
2 or 3	A55_P297-9
4 or 5	A133_P194-1 (TB22-1) (A133 DIP set to GP)
6 or 7	A133_P194-2 (TB22-2) (A133 DIP set to GP)
8 or 9	A133_P194-1 (TB19-1) (A133 DIP set to MGV)
10 or 11	A133_P194-2 (TB19-2) (A133 DIP set to MGV)
12 or 13	A133_P194-1 (TB18-1) (A133 DIP set to VAV)
14 or 15	A133_P194-2 (TB18-2) (A133 DIP set to VAV)

This option also selects the digital input used and determines which compressors are shed on units equipped with 1 or 3 (odd) compressors. See table 38.

Table 38. Compressors Disabled by Load Shedding Options

Unit Size	Compressors Disabled By Option 2, 4, 6, 8, 10, 12, 14	Compressors Disabled By Option 3, 5, 7, 9, 11, 13, 15
1 Compressor	None	CP1
2 Compressors	CP2	CP2
3 Compressors	CP3	CP2 & CP3
4 Compressors	CP3 & CP4	CP3 & CP4

To shut down the whole unit, Digital Input DI 3 on the A55_P299_6 (A42) can be de-energized. This feature must be enabled through Prodigy unit configuration.

The M2 readout will display "LS" when the unit is in load shedding mode.

The special option 1 will shed all compressors when the DI-3 input opens (de-energizes). This option is available on M2 v7.07 and later.

15. Service Relay

15.1. Service Relay Operation

The M2 Service Relay output (A55_P298-8) default operation indicates that service is required. Table 40 indicates these critical alarms with an asterisk.

If the default operation is not required, the Service Relay output may be used as a control output. Use ECTO 7.22 to choose the input which will trigger the Service Relay output. The formula $X + (32 \times Y) + (16 \times Z)$ is used to select the option. See table 39.

If ECTO 7.22 input sources 7-9 are used, the set point and dead-band must be set with ECTO 7.23 and 7.24.

Table 39. Service Relay Options

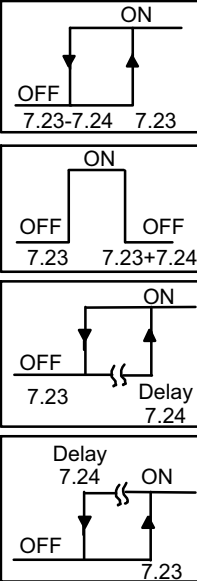
Control Parameter		Control Value			Units	Description
No.	Name	Min	Default	Max.		
7.22	Service_ Output_ Control_Mode	0	0	127	Option	<p>A55 Service Output Control Mode = $X + 32 \times Y + 16 \times Z$ Input source = X: 0- None. Standard Service Output based on alarms. 1- Compressor 1 duty cycle. (Compressor crankcase heater function.) On when OAT \leq ECTO 7.23 and \geq ECTO 7.24 seconds have passed with compressor 1 off. Off when OAT $>$ ECTO 7.23 + 3 deg F (fixed dead-band) or $<$ ECTO 7.24 seconds have passed with compressor 1 off 2- On when occupied. 3- On when blower on, 4- On when heating demand. 5- On when cooling demand. 6- On when heating or cooling demand. 7- System RH (A55_P298_5 RH) 8- System IAQ. (A55_P298_3 IAQ) 9- System OAT (A55_P267_1/2 OAT)</p> <p>Algorithm Y for input sources 7-9: 0- Hysteresis loop On when input \geq ECTO 7.23 Off when input $<$ ECTO 7.23-ECTO 7.24</p> <p>1- Window On when input is in range; \geq ECTO 7.23 and \leq ECTO 7.23 + ECTO 7.24 (Fixed 3-count hysteresis loop on rising and falling edges of window.)</p> <p>2- Delayed-on. On when input is \geq ECTO 7.23 for \geq ECTO 7.24 seconds. Off when input is $<$ ECTO 7.23-3. (Fixed 3-count hysteresis loop on edge.)</p> <p>3- Delayed-off. On when input is \geq ECTO 7.23. Off when input is $<$ ECTO 7.23 - 3 for \geq ECTO 7.24 seconds. (Fixed 3-count hysteresis loop on edge.)</p> <p>Inversion Z: 0- Output not inverted. 1- Output inverted.</p>
						 <p>Graphs indicate output not inverted. See figure 33.</p>
7.23	Service_ Output_SP	0 0 0 132	127 996 100 51	255 2000 100 -31	Counts I:ppm P: % Y:DegF	A55 service relay output set point.
7.24	Service_ Output_DB	2 16 2 1 64	13 102 13 8 416	255 2000 100 162 8160	Counts I:ppm P: % O:DegF D:Sec.	A55 service relay output dead-band or delay.

Example 1: Use the Service output to energize a dehumidifier at 60% RH and turn off at 55% RH. (Refer to figure 31.)

<ol style="list-style-type: none"> 1. Determine: ECTO 7.22- Input Source X to option "7" (RH) Algorithm Y to option "0" (hysteresis loop) Inversion Z option "0" (output not inverted) 2. Apply step 1 to ECTO 7.22 formula: $\begin{aligned} \text{ECTO 7.22} &= X + (32 \times Y) + (16 \times Z) \\ &= 7 + (32 \times 0) + (16 \times 0) \\ &= 7 \end{aligned}$ 3. Set ECTO 7.22 to "7". 4. Set ECTO 7.23 to 60% (60 counts) for 60% RH 5. Set ECTO 7.24 to 5% (5 counts) for 5% dead-band. 	
--	--

Figure 31. Example 1. Service output energizes dehumidifier at 60% RH / turns off at 55% RH

Example 2: Use the service output to energize a humidifier at 30% RH and turn off at 35% RH. (Refer to figure 32.)

<ol style="list-style-type: none"> 1. Determine: ECTO 7.22- Input Source X to option "7" (RH) Algorithm Y to option "0" (hysteresis loop) Inversion Z option "1" (output inverted) 2. Apply step 1 to ECTO 7.22 formula: $\begin{aligned} \text{ECTO 7.22} &= X + (32 \times Y) + (16 \times Z) \\ &= 7 + (32 \times 0) + (16 \times 1) \\ &= 7 + 0 + 16 \\ &= 23 \end{aligned}$ 3. Set ECTO 7.22 to "23". 4. Set ECTO 7.23 to 35% (35 counts) for 35% RH 5. Set ECTO 7.24 to 5% (5 counts) for 5% dead-band. 	
---	--

Figure 32. Example 2. Service output energizes dehumidifier at 30% RH / turns off at 35% RH

15.2. OAT Operation

Figure 33 shows the service output being energized at 80°F and off at 70°F (inverted) and the service output operation being energized at 70°F and off at 80°F (not inverted).

IMPORTANT - This applies to input source option 9 (OAT) on ECTO 0.23, 3.21, 7.22, and 9.23.

<p>7.23-7.24 81 COUNTS 80°F</p> <p>7.23 97 COUNTS 70°F</p> <p>Output Inverted - Input source 9 only</p>	<p>7.23-7.24 81 COUNTS 80°F</p> <p>7.23 97 COUNTS 70°F</p> <p>Output NOT Inverted - Input source 9 only</p>
--	--

Figure 33. OAT Operation - Service output energized

16. Diagnostics

16.1. M2 Event Codes

When an event occurs, the M2 Unit Controller will display a code which corresponds to control function. See table 40. Error codes are stored and can be recalled later. See the *Installation & Setup Guide For The Prodigy M2 Unit Controller* for information about viewing and silencing the alarms via the user interface.

Table 40. M2 Event Codes

Code	Display Message	Action
0		
1	ALARM(1) ERRATIC POWER	CHECK POWER CONNECTIONS
2	ALARM(2) CHECK SETTINGS	RESET CONTROLLER. CHECK UNIT SETTINGS. CONTACT LENNOX IF PROBLEM PERSISTS.
3	Reserved	
4	ALARM(4) SMOKE A173	SMOKE MODE. CHECK FOR SOURCE OF SMOKE.
5	ALARM(5) BLOWER S52	UNIT OFF. AIR FLOW SWITCH OPEN 16 SEC AFTER DEMAND. CHECK BLOWER PARTS
6	ALARM(6) FILTER S27	REPLACE FILTER OR CHECK FILTER SWITCH S27
7	ALARM(7) CONTROLLER PROBLEM	RESET CONTROLLER. CHECK UNIT SETTINGS. CONTACT LENNOX IF PROBLEM PERSISTS.
8	ALARM(8) STRIKE 3 ON BLOWER S52	LOCKOUT. MULTIPLE CODE 5. CHECK BLOWER PARTS
9 – 11	Reserved	
12	ALARM(12) COMP 1 HIGH PRESS S4	COMP OFF. CHECK CHARGE, FANS, COIL.
13	ALARM(13) STRIKE 3 ON COMP 1 HIGH PRESS S4	COMP LOCKOUT. CHECK CHECK CHARGE, FANS, COIL. USE SERVICE MENU TO CLEAR LOCKOUTS.
14	ALARM(14) COMP 2 HIGH PRESS S7	COMP OFF. CHECK CHARGE, FANS, COIL.
15	ALARM(15) STRIKE 3 ON COMP 2 HIGH PRESS S7	COMP LOCKOUT. CHECK CHECK CHARGE, FANS, COIL. USE SERVICE MENU TO CLEAR LOCKOUTS.
16	ALARM(16) COMP 3 HIGH PRESS S28	COMP OFF. CHECK CHARGE, FANS, COIL.
17	ALARM(17) STRIKE 3 ON COMP 3 HIGH PRESS S28	COMP LOCKOUT. CHECK CHARGE, FANS, COIL. USE SERVICE MENU TO CLEAR LOCKOUTS.
18	ALARM(18) COMP 4 HIGH PRESS S96	COMP OFF. CHECK CHARGE, FANS, COIL.
19	ALARM(19) STRIKE 3 ON COMP 4 HIGH PRESS S96	COMP LOCKOUT. CHECK CHECK CHARGE, FANS, COIL. USE SERVICE MENU TO CLEAR LOCKOUTS.
NOTE - Alarms 12-19 could also be caused by a high temperature condition on some compressors equipped with a high temperature shutdown.		
20	ALARM(20) UNIT SHUTDOWN A42	CHECK PHASE MONITOR
21	ALARM(21) STRIKE 3 UNIT SHUTDOWN A42	CHECK PHASE MONITOR
22	ALARM(22) COMP 1 LOW PRESS S87	COMP OFF. CHECK CHARGE, FILTERS, AIR FLOW. COIL
23	ALARM(23) STRIKE 3 ON COMP 1 S87	COMP LOCKOUT. CHECK CHECK CHARGE, FILTER, AIR FLOW, COIL. USE SERVICE MENU TO CLEAR LOCKOUTS.
24	ALARM(24) COMP 2 LOW PRESS S88	COMP OFF. CHECK CHARGE, FILTERS, AIR FLOW. COIL
25	ALARM(25) STRIKE 3 ON COMP 2 S88	COMP LOCKOUT. CHECK CHECK CHARGE, FILTER, AIR FLOW, COIL. USE SERVICE MENU TO CLEAR LOCKOUTS.
26	ALARM(26) COMP 3 LOW PRESS S98	COMP OFF. CHECK CHARGE, FILTERS, AIR FLOW. COIL
27	ALARM(27) STRIKE 3 ON COMP 3 S98	COMP LOCKOUT. CHECK CHECK CHARGE, FILTER, AIR FLOW, COIL. USE SERVICE MENU TO CLEAR LOCKOUTS.
28	ALARM(28) COMP 4 LOW PRESS S97	COMP OFF. CHECK CHARGE, FILTERS, AIR FLOW. COIL
29	ALARM(29) STRIKE 3 ON COMP 4 S97	COMP LOCKOUT. CHECK CHECK CHARGE, FILTER, AIR FLOW, COIL. USE SERVICE MENU TO CLEAR LOCKOUTS.
30	ALARM(30) UNIT SHUTDOWN S149	CHECK OVERFLOW SW

table continued on next page

Code	Display Message	Action
31	ALARM(31) STRIKE 3 UNIT SHUT-DOWN S149	CHECK OVERFLOW SW
32	ALARM(32) COMP 1 FRZSTAT OPEN S49	COMP OFF. CHECK FRZSTAT, AIR FLOW, CHARGE, COIL, FILTER, OUTSIDE TEMP
33	ALARM(33) STRIKE 3 COMP 1 FRZ-STAT OPEN S49	COMP LOCKOUT. CHECK FRZSTAT, AIR FLOW, CHARGE, COIL, FILTER, OUTSIDE TEMP
34	ALARM(34) COMP 2 FRZSTAT OPEN S50	COMP OFF. CHECK FRZSTAT, AIR FLOW, CHARGE, COIL, FILTER, OUTSIDE TEMP
35	ALARM(35) STRIKE 3 COMP 2 FRZ-STAT OPEN S50	COMP LOCKOUT. CHECK FRZSTAT, AIR FLOW, CHARGE, COIL, FILTER, OUTSIDE TEMP
36	ALARM(36) COMP 3 FRZSTAT OPEN S53	COMP OFF. CHECK FRZSTAT, AIR FLOW, CHARGE, COIL, FILTER, OUTSIDE TEMP
37	ALARM(37) STRIKE 3 COMP 3 FRZ-STAT OPEN S53	COMP LOCKOUT. CHECK FRZSTAT, AIR FLOW, CHARGE, COIL, FILTER, OUTSIDE TEMP
38	ALARM(38) COMP 4 FRZSTAT OPEN S95	COMP OFF. CHECK FRZSTAT, AIR FLOW, CHARGE, COIL, FILTER, OUTSIDE TEMP
39	ALARM(39) STRIKE 3 COMP 4 FRZ-STAT OPEN S95	COMP LOCKOUT. CHECK FRZSTAT, AIR FLOW, CHARGE, COIL, FILTER, OUTSIDE TEMP
40	ALARM(40) RETURN AIR OVER HEAT LIMIT RT16	HEAT ABOVE SETPOINT. CHECK SPACE CONDITIONS OR SENSOR
41	ALARM(41) RETURN AIR UNDER COOL LIMIT RT16	COOL BELOW SETPOINT. CHECK SPACE CONDITIONS OR SENSOR
42	ALARM(42) UNIT SHUTDOWN S42 OR S135	CHECK EXT MTR OVERLOADS
43	ALARM(43) STRIKE 3 UNIT SHUT-DOWN S42 OR S135	CHECK EXT MTR OVERLOADS
44	ALARM(44) GAS VALVE ON NO DEMAND GV1	UNIT OFF. GV1 POWER BUT NO DEMAND. CHECK GAS PRESS, GAS VALVE
45	ALARM(45) GAS VALVE ON NO DEMAND GV3	UNIT OFF. GV3 POWER BUT NO DEMAND. CHECK GAS PRESS, GAS VALVE
46 – 49	Reserved	
50	ALARM(50) PRIMARY HEAT 1 LIMIT OPEN S10	HEAT SECT 1 PRIMARY HEAT LIMIT OPEN. CHECK AIR FLOW, LIMIT, AND WIRING.
51	ALARM(51) STRIKE 3 PRIMARY HEAT 1 LIMIT OPEN S10	HEAT SECT 1 PRIMARY HEAT LIMIT OPEN. CHECK AIR FLOW, LIMIT, AND WIRING.
52	ALARM(52) SECONDARY HEAT 1 LIMIT OPEN S21	HEAT SECT 1 SECONDARY HEAT LIMIT OPEN. CHECK AIR FLOW, LIMIT, AND WIRING.
53	ALARM(53) STRIKE 3 SECONDARY HEAT 1 LIMIT OPEN S21	HEAT SECT 1 SECONDARY HEAT LIMIT OPEN. CHECK AIR FLOW, FILTER, LIMIT, AND WIRING.
54	ALARM(54) HEAT 1 ROLL OUT OPEN	HEAT SECT 1 CHECK GAS ROLL OUT S47
	ALARM(54) HEAT 1 S15 LIMIT OPEN	HEAT SECT 1 LIMIT OPEN. CHECK AIR FLOW, LIMIT, AND WIRING.
55	ALARM(55) STRIKE 3 HEAT 1 ROLL OUT OPEN	HEAT SECT 1 CHECK GAS ROLL OUT S47
	ALARM(55) STRIKE 3 HEAT 1 S15 LIMIT OPEN	HEAT SECT 1 LIMIT OPEN. CHECK AIR FLOW, LIMIT, AND WIRING.
56	ALARM(56) HEAT 1 CAI SWITCH S18	HEAT SECT 1 CHECK COMBUSTION AIR MOTOR & PROOF SWITCH
57	ALARM(57) STRIKE 3 HEAT 1 CAI SWITCH S18	HEAT SECT 1 OFF CHECK COMBUSTION AIR MOTOR & PROOF SWITCH
58	ALARM(58) HEAT 1 NO PROOF GAS VALVE GV1	HEAT SECT 1 CHECK IGNITION CONTROL, FLAME PROOF, GV1, GAS SUPPLY
59	ALARM(59) STRIKE 3 NO PROOF GAS VALVE GV1	HEAT SECT 1 CHECK IGNITION CONTROL, FLAME PROOF, GV1, GAS SUPPLY
60	ALARM(60) PRIMARY HEAT 2 LIMIT OPEN S99	HEAT SECT 2 PRIMARY HEAT LIMIT OPEN. CHECK AIR FLOW, LIMIT, AND WIRING.
61	ALARM(61) STRIKE 3 PRIMARY HEAT 2 LIMIT OPEN S99	HEAT SECT 2 PRIMARY HEAT LIMIT OPEN. CHECK AIR FLOW, LIMIT, AND WIRING.

table continued on next page

Code	Display Message	Action
62	ALARM(62) HEAT 2 LIMIT OPEN S100	HEAT SECT 2 SECONDARY HEAT LIMIT OPEN. CHECK AIR FLOW, LIMIT, AND WIRING.
63	ALARM(63) STRIKE 3 HEAT 2 LIMIT OPEN S100	HEAT SECT 2 SECONDARY HEAT LIMIT OPEN. CHECK AIR FLOW, FILTER, LIMIT, AND WIRING.
64	ALARM(64) HEAT 2 ROLLOUT OPEN S69	CHECK ROLLOUT SENSOR AND GAS
65	ALARM(65) STRIKE 3 ROLLOUT OPEN S69	CHECK ROLLOUT SENSOR AND GAS
66	ALARM(66) HEAT 2 CAI SWITCH S45	HEAT SECT 2 CHECK COMBUSTION AIR MOTOR & PROOF SWITCH
67	ALARM(67) STRIKE 3 HEAT 2 CAI SWITCH S45	HEAT SECT 2 OFF CHECK COMBUSTION AIR MOTOR & PROOF SWITCH
68	ALARM(68) HEAT 2 NO PROOF GAS VALVE GV3	HEAT SECT 2 CHECK IGNITION CONTROL, FLAME PROOF, GV3, GAS SUPPLY
69	ALARM(69) STRIKE 3 NO PROOF GAS VALVE GV3	HEAT SECT 2 CHECK IGNITION CONTROL, FLAME PROOF, GV3, GAS SUPPLY
70 – 72	Reserved	
73	ALARM(73) NETWORK SENSOR ERROR	CHECK WITH INTEGRATOR FOR REFRESH RATE, NETWORK STATUS LIGHTS AND WIRING
74	ALARM(74) ZONE SENSOR A2	CHECK ZONE SENSOR AND WIRING
75	ALARM(75) OUTDOOR TEMP SENSOR RT17	CHECK SENSOR AND WIRING
76	ALARM(76) HUMIDITY SENSOR A91	CHECK SENSOR AND WIRING
77	ALARM(77) DISCHARGE AIR TEMP SENSOR RT6	CHECK SENSOR AND WIRING
78	ALARM(78) RETURN AIR TEMP SENSOR RT16	CHECK SENSOR AND WIRING
79	ALARM(79) ADD-ON BOARD PROBLEM	ADD-ON BRD PROBLEM, RESET TO CLEAR
80	ALARM(80) ADD-ON BOARD PROBLEM	ADD-ON BRD PROBLEM
81	ALARM(81) REHEAT SETUP ERROR	CHECK REHEAT SETTINGS
82	ALARM(82) CONTROLLER RESET	NO ACTION NEEDED
83	ALARM(83) INCORRECT SETTINGS	CHECK CONFIGURATION
84	Reserved	
85	ALARM(85) INCORRECT HUMIDITROL SETTINGS	CHECK HUMIDITROL SETTINGS
86	ALARM(86) CONFLICTING TSTAT INPUT	CHECK TSTAT INPUTS FOR SIMULTANEOUS HEAT AND COOL AND WIRING
87	Reserved	
88	ALARM(88) CONTROLLER PROBLEM	INTERNAL CONTROLLER PROBLEM. RESET TO CLEAR.
89	Reserved	
90	ALARM(90) CONTROLLER PROBLEM	INTERNAL CONTROLLER PROBLEM. RESET TO CLEAR.
91	ALARM(91) OUTDOOR ENTH SENSOR A7	CHECK ECON DIP SWITCH AND ENTH DIAL SETTINGS, SENSOR AND WIRING
92	ALARM(92) INDOOR ENTH SENSOR A62	CHECK ECON DIP SWITCH AND ENTH DIAL SETTINGS, SENSOR AND WIRING
93	ALARM(93) BACKUP MODE	CHECK COMM LOSS WITH NETWORK SENSOR
94	ALARM(94) BAD ZONE SENSOR SETPOINT	CHECK SETPOINT AND EMS PROGRAMMING
95	ALARM(95) SETTINGS HAVE CHANGES	SETTINGS HAVE CHANGED AT THE UNIT
96	Reserved	
97	Reserved	

table continued on next page

Code	Display Message	Action
98	ALARM(98) CONTROLLER PROBLEM	INTERNAL CONTROLLER PROBLEM. RESET TO CLEAR.
99	ALARM(99) OUTDOOR ECON SENSOR A24	CHECK SENSOR AND WIRING
100	ALARM(100) AIR VOL CONTROL SETUP ERROR	CHECK FOR PROPER INSTALLATION OF GP BOARD AND SETTINGS
101	ALARM(101) MGV CONTROL SETUP ERROR	CHECK FOR PROPER INSTALLATION OF GP BOARD AND SETTINGS
102	ALARM(102) GP CONTROL SETUP ERROR	CHECK FOR PROPER INSTALLATION OF GP BOARD AND SETTINGS
103	ALARM(103) ADVANCED CONTROL SETUP ERROR	CHECK PRODIGY SETTINGS
104	Reserved	
105	ALARM(105) ADVANCED ECON CONTROL SETUP ERROR	CHECK ECON SWITCHES, DIALS, AND PRODIGY SETTINGS
106	ALARM(106) BUILDING PRESS SENSOR A34	CHECK SENSOR AND WIRING
107	ALARM(107) DUCT SUPPLY PRESS SENSOR A30	CHECK SENSOR AND WIRING
108	ALARM(108) DUCT SUPPLY HIGH PRESS SENSOR A30	CHECK SENSOR AND WIRING
109	ALARM(109) STRIKE 3 DUCT SUPPLY PRESS SENSOR A30	CHECK SENSOR AND WIRING
110	ALARM(110) WAITING ON NETWORK DATA	CHECK NETWORK OR COMFORT SENSOR AND WIRING
111	ALARM(111) CONTROLLER PROBLEM	INTERNAL CONTROLLER PROBLEM. RESET TO CLEAR.
112	ALARM(112) CONTROLLER PROBLEM	INTERNAL CONTROLLER PROBLEM. RESET TO CLEAR.
113	Reserved	
114	ALARM(114) CONTROLLER PROBLEM	POWER NOISE PROBLEM. RESET TO CLEAR.
115	ALARM(115) UNIT OFFLINE FOR TEST	CHECK PRODIGY SERVICE TEST MODE
116	Reserved	
117	Reserved	
118	ALARM(118) NO DISPLAY	DISPLAY NOT DETECTED
119	STATUS(119) RESET CAUSED BY WATCHDOG TIMEOUT	CONTACT LENNOX
120	ALARM(120) ADD-ON BOARD MCB PROBLEM	MCB CONFIGURATION SETUP PROBLEM. RESET TO CLEAR OR ADVANCED SETUP.
121	ALARM(121) LINE FREQ DOES NOT MATCH UNIT CONFIG	
122	ALARM(122) 24VAC PRIMARY VOLTAGE LOW	
123	ALARM(123) 24VAC PRIMARY VOLTAGE HIGH	
124	ALARM(124) 24VAC SECONDARY VOLTAGE LOW	
125	ALARM(125) 24VAC SECONDARY VOLTAGE HIGH	
126	ALARM(126) LINE PHASING DOES NOT MATCH UNIT CONFIG	
127	Reserved	
128	ALARM(128) 24VAC POWER LOSS	
129	Reserved	

17. Electronic Configure To Order (ECTO) Control Parameters

Many M2 main control operations may be varied within a set range. Default settings are based on common or average applications; change ECTO settings only when custom applications, preferences or local building codes exist. Default, minimum, and maximum range settings are found in table 41.

NOTICE: Units with Novar 2051 module!

Failure to perform the following steps may result in unsatisfactory unit operation.

1. Prior to changing ECTO's, unplug the Novar phone cable to M2 sysbus.
2. When ECTO changes are complete, return DB1 to DISPLAY mode and reconnect the Novar phone cable.

ECTO parameters may be changed two different ways:

- using the Prodigy Display
- using an optional PC Unit Controller (UC) software

17.1. Using the Prodigy Display

Set ECTOs using Prodigy menu, SETTINGS > CONTROL > ECTO. Refer to the Prodigy Installation and Setup Guide.

The parameters are set up in ten different blocks or groups. The first digit of each parameter indicates the block as follows:

- 0- VAV/CAVB
- 1- heat pump heating
- 2- electric heating
- 3- gas heating
- 4- cooling
- 5- miscellaneous
- 6- system 1
- 7- system 2
- 8- system 3
- 9- GP board

An M2 board configured for a gas heating unit will skip heat pump block 1 and electric heating block 2 readouts. An M2 board configured for an electric heating unit will skip heat pump block 1 and gas heating block 3 readouts. An M2 board configured for a heat pump unit will skip electric heating block 2 and gas heating block 3 readouts.

17.2. Reset To Factory ECTO Parameters

To restore the factory ECTO parameters, refer to the Prodigy Installation and Setup Guide.

17.3. Unit Controller PC Software

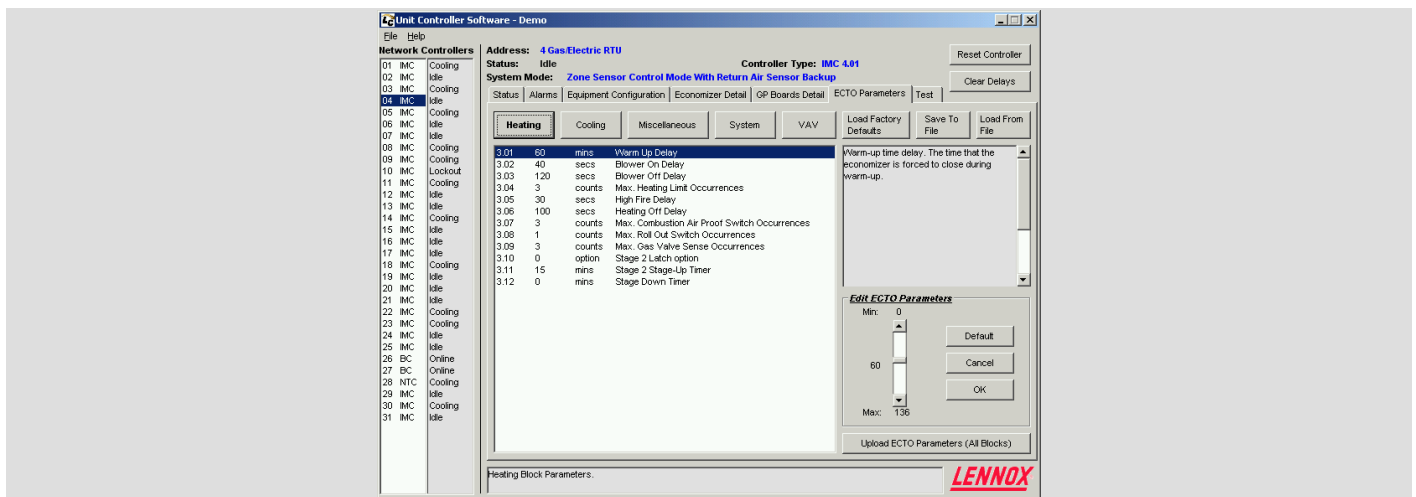

The L connection unit controller PC software is recommended when adjusting multiple ECTO parameters. Unit controller PC software allows the user to adjust parameters using real units (no conversion from display readout). PC software is faster than using the push-button/display interface on the M2 board.

In addition, the PC software allows the user to save unit configuration files. The saved file can be used to apply the same settings to other units.

The unit controller software can directly access a unit by plugging into the M2 board phone jack and connecting to a serial port using a PC converter. Any unit on the same daisy-chained network can be adjusted from any unit M2 board or the NCP. A LAN Ethernet converter and phone modem are also available for remote connections.

Table 41. M2 ECTO Control Parameters

Control Parameter		Control Value			Units	Description
No.	Name	Min.	Default	Max.		
A BOX 3-5 ton		Block 0 MSAV Parameters				
0.01	Supply_VAV_Control_Mode	0	0 (6 ton) 64 (3,4,5 ton Std Eff) 68 (3 ton High Eff) 72 (4 ton High Eff) 76 (5 ton High Eff)	255	Option	Supply VAV control mode selection by weight: 4 - MCB 3 ton direct drive 8 - MCB 4 ton direct drive 12 - MCB 5 ton direct drive 16 - MCB indoor blower high speed when running on OCP 32 - MCB indoor blower high speed when running on G 64 - MCB exists
0.02	VAV_SMK_Stg_Output	0 0	55 (3,4,5 ton Std Eff) 55 (3 ton High Eff) 80 (4 ton High Eff) 59 (5 ton High Eff)	100 100	Counts P: %	Blower staged % output during smoke detection.
0.04	VAV_HT_Stg_Output	0 0	55 (3,4,5 ton Std Eff) 55 (3 ton High Eff) 80 (4 ton High Eff) 59 (5 ton High Eff)	100 100	P: %	Blower staged % output high speed; used for heating and high cooling or ventilation.
0.05	VAV_CL_Stg_1_Output	0 0	28 (3,4,5 ton Std Eff) 28 (3 ton High Eff) 40 (4 ton High Eff) 36 (5 ton High Eff)	100 100	P: %	Blower staged % output low speed; used for low cooling or ventilation.
0.09	Min_Damper_Position_Low_BLR	0 0	30 30	100 100	P: %	Minimum damper position during low speed blower operation. Use ECTO 5.24 during high speed blower operation
0.27	Free_CL_Stg_Up_Delay	0 0	38 304	255 2040	Counts C: Sec	Free cooling blower stage-up delay. Blower runs low speed during delay, and then shifts to high speed. Set to 0 for immediate high speed, or XXX to stay in low speed.
A (6 ton), B, C, D, & E BOXES Block 0 VAV, CAVB, & MSAV Parameters						
0.01	Supply_VAV_Control_Mode	0	0	63	Option	Add the weights for each control description to determine option. Weight- Description 1- GP1 board present, DIP set to VAV mode for VAV or CAVB control action. 2- VAV control action. 0 for CAVB control action. See table 29. The following weights are used for VAV: 4- PID control when smoke detected. 0 for staged 8- PID control when running ventilation. 0 for staged. 16- PID control when running cooling. 0 for staged. 32- PID control when running heating. 0 for staged For VAV control action, either PID or staged control can be selected. For CAVB control action, PID is automatically used. (Staged is not available for CAVB). Configuration alarm will occur if GP board (W/DIP set to VAV) is installed and at least one of the following ECTO parameters value are not set to non-zero: ECTO 0.01, 0.23 or 8.16
0.02	VAV_Press_SMK_SP	0 0	51 1.00	255 5.0	Counts N:"w.c.	VAV supply static pressure set point during smoke detection.
	VAV_SMK_Stg_Output	0	51	100	P: %	VAV staged % output during smoke detection.
0.03	VAV_Press_Vent_SP	0 0	51 1.00	255 5.0	Counts N:"w.c.	VAV supply static pressure set point during ventilation.
	VAV_VT_Stg_Output	0	51	100	P:%	VAV staged % output during ventilation and economizer free cooling.
0.04	VAV_Press_HT_SP	0 0	51 1.00	255 5.0	Counts N:"w.c.	VAV supply static pressure set point during heating.
	VAV_HT_Stg_Output	0	51	100	P:%	VAV staged % output during heating.
0.05	VAV_Press_CL_SP	0 0	51 1.00	255 5.0	Counts N:"w.c.	VAV supply static pressure set point during cooling.
	VAV_CL_Stg_1_Output	0	51	100	P:%	VAV staged % output while cooling compressor 1 is on.

table continued on next page

Control Parameter No.	Name	Control Value			Units	Description
		Min.	Default	Max.		
B, C, D, & E BOXES Block 0 VAV, CAVB, & MSAV Parameters (continued)						
0.06	VAV_Min_Output_for_CL_VT_SMK	30 30	50 50	100 100	Counts P: %	VAV supply minimum output for cooling, ventilation or smoke. If minimum is >= manual reset (ECTO 0.09), then manual reset used is shifted to (ECTO 0.06 + ECTO 0.08) / 2
0.07	VAV_Min_Output_for_HT	30 30	50 50	100 100	Counts P: %	VAV supply minimum output for heating. If minimum is >= manual reset (ECTO 0.09), then manual reset used is shifted to (ECTO 0.07 + ECTO 0.08) / 2
0.08	VAV_Max_Output	40 40	100 100	100 100	Counts P: %	VAV supply maximum output.
0.09	VAV_PID_ManRS	0 0	60 60	100 100	Counts P: %	VAV supply PID manual reset value. If minimum output, ECTO 0.06 or 0.07 is greater, a computed ManRS value is used. See ECTO 0.06 and 0.07.
0.10	PID_P_Constant	0	17	127	Counts	VAV or CAVB supply PID Proportional constant.
0.11	PID_I_Constant	0	12	127	Counts	VAV or CAVB supply PID Integral constant.
0.12	PID_D_Constant	0	0	127	Counts	VAV or CAVB supply PID derivative constant.
0.13	CAVB_SMK_SP	0 0	51 1.00	255 5.0	Counts N:"w.c.	Constant air volume with bypass damper static pressure set point during smoke alarm.
0.14	CAVB_VT_SP	0 0	51 1.00	255 5.0	Counts N:"w.c.	Constant air volume with bypass damper static pressure set point for ventilation.
	VAV_CL_Stg_2_Output	0	51	100	P: %	VAV staged % output while cooling compressors 1 and 2 are on.
0.15	CAVB_HT_SP	0 0	51 1.00	255 5.0	Counts N:"w.c.	Constant air volume with bypass damper static pressure set point for heating
	VAV_CL_Stg_3_Output	0	51	100	P: %	VAV staged % output while cooling compressors 1, 2, and 3 are on.
0.16	CAVB_CL_SP	0 0	51 1.00	255 5.0	Counts N:"w.c.	Constant air volume with bypass damper static pressure set point for cooling
	VAV_CL_Stg_4_Output	0	51	100	P: %	VAV staged % output while cooling compressors 1, 2, 3, and 4 are on.
0.17	CAVB_Min_Output_for_CL_VT_SMK	20 20	20 20	100 100	Counts P: %	Constant air volume with bypass damper minimum output for cooling, ventilation and during smoke alarms. This sets the minimum air delivered. Bypass damper motor is set to 10 to 2 volts with 10 v being closed. 20% setting = 2 volts or damper completely opened.
0.18	CAVB_Min_Output_for_HT	20 20	20 20	100 100	Counts P: %	Constant air volume with bypass damper minimum output for heating. This sets the minimum air delivered. Bypass damper motor is set to 10 to 2 volts with 10 v being closed. 20% setting = 2 volts or damper completely opened.
0.19	CAVB_Max_output	40 40	100 100	100 100	Counts P: %	Constant air volume with bypass damper maximum output. This sets the maximum air delivered. Bypass damper motor is set to 10 to 2 volts with 10 v being closed. 100% setting = 10 volts or damper completely closed.
0.20	CAVB_ManRS	20 20	52 52	100 100	Counts P: %	Constant air volume with bypass damper manual reset value output. This is the output when unit is off.
0.21	Static_Shutdown_SP	0 0	102 2.0	255 5.0	Counts N:"w.c.	Supply static shutdown set point. Unit will shutdown for ECTO 5.02 minutes if duct pressure exceeds this value for 20 seconds.
0.22	Static_Lockout_Counts	0	3	8	Counts	The number of occurrences before permanent lockout. Counter resets when M2 resets. A value of 0 will disable lockout.

table continued on next page

Control Parameter		Control Value			Units	Description
No.	Name	Min.	Default	Max.		
B, C, D, & E BOXES Block 0 VAV, CAVB, & MSAV Parameters (continued)						
0.23	DO_Mode_A133_(VAV mode)	0	0	127	Option	<p>A133 (w/DIP set to VAV) Digital Out Mode = X + 32*Y + 16*Z Input source= X:</p> <ul style="list-style-type: none"> 0- None. Output enables exhaust fan stage 2. 1- Compressor 1 duty cycle. (Compressor crankcase heater function.) On when OAT <= ECTO 0.24 and >= ECTO 0.25 seconds have passed with compressor 1 off. Off when OAT > ECTO 0.24 + 3 deg F (fixed dead-band) or < ECTO 0.25 sec have passed with compressor 1 off. 2- On when occupied. 3- On when blower on. 4- On when heating demand. 5- On when cooling demand. 6- On when heating or cooling demand. 7- System RH (A55_P298_5 RH) 8- System IAQ. (A55_P298_3 IAQ) 9- System OAT (A55_P267_1/2 OAT) 10- AI1. (A133_P194-6). 11- AI2. (A133_P194-7). 12- AI3. (A133_P194-8). 13- AI4. (A133_P194-9). 14- AO1. (A133_P194-11). 15- AO2. (A133_P194-12). <p>Algorithm Y for input sources 7-15:</p> <ul style="list-style-type: none"> 0- Hysteresis loop On when input >= ECTO 0.24 Off when input < ECTO 0.24-ECTO 0.25 1- Window On when input is in range; >= ECTO 0.24 and <= ECTO 0.24 + ECTO 0.25 (Fixed 3-count hysteresis loop on rising and falling edges of window.) 2- Delayed-on. On when input is >= ECTO 0.24 for >= ECTO 0.25 seconds. Off when input is < ECTO 0.24 - 3. (Fixed 3-count hysteresis loop on edge.) 3- Delayed-off. On when input is >= ECTO 0.24. Off when input is < ECTO 0.24 - 3 for >= ECTO 0.25 seconds. (Fixed 3-count hysteresis loop on edge.) <p>Inversion Z: 0 - Output not inverted. 1 - Output inverted.</p> <p style="text-align: right;">Graphs indicate output not inverted. See figure 33.</p>
0.24	DO_SP_A133_(VAV mode)	0 0 0 132 -0.5 0	127 5.0 996 100 51 0 2.5	255 10.0 2000 100 -31 0.5 5.0	Counts R:Volts I:ppm P:% Y:DegF M:"w.c. N:"w.c.	A133 (w/DIP set to VAV) digital output mode set point
0.25	DO_DB_A133_(VAV mode)	2 0 16 2 1 64 0.01 0	13 .50 102 13 8 416 0.05 .25	255 10.0 2000 100 162 8160 1.0 5.0	Counts R:Volts I:ppm P:% O:DegF D:Sec. L:"w.c. N:"w.c.	A133 (w/DIP set to VAV) digital output mode dead-band or delay.
0.26	Supply_Static_Sensor_Low_Alarm_Check	30 30	40 40	101 101	Count P:%	Supply Static Pressure Sensor (A30) connected at (A133_P195_6) (TB18_6) alarm threshold. Blower percent speed before checking sensor after a 20 second delay. A value of 101 disables the low threshold or "open" alarm trap.

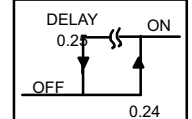
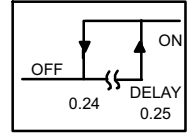
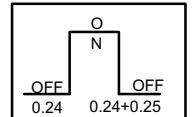
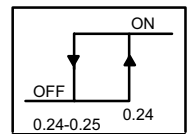

table continued on next page

Control Parameter		Control Value			Units	Description
No.	Name	Min.	Default	Max.		
Block 1 Heat Pump Heating Parameters						
1.01	WmUp_Delay	28 896	56 1792	255 8160	Counts D:Sec.	Warm-up time delay. The time that the supplemental heat is held off during the first demand of warm-up. This parameter is only used if the parameter 1.17 is set to option 1.
1.02	BL_On_Delay	0 0	0 0	15 60	Counts B:Secs	Blower on delay. The time before the blower turns on after a heating demand.
1.03	BL_Off_Delay	0 0	5 20	75 300	Counts B:Secs	Blower off delay. The time the blower stays on after the heating demand is lost
1.04	Max_HT_LT_Occurrences	1	5	15	Counts	Service output activation. Maximum Primary and Secondary Limit occurrences stored before service relay is energized. If max value is set, service output is disabled. Note: Heating stage is not locked out.
1.05	Sup_HT_Stg_Delay	3 12	3 12	15 60	Counts B:Secs	Time delay between 1 & 2 stage of supplemental heat.
1.06	Sup_HT_2_Lockout_Temp.	113 60	160 30	175 20	Counts Y:DegF	Temperature set point for lockout for the second bank of supplemental heat. Note: Temperature must be < or = to ECTO 1.07.
1.07	Sup_HT_1_Lockout_Temp.	113 60	144 40	175 20	Counts Y: Deg.	Temperature set point for lockout of first bank of supplemental heat. Note: Temperature must be = to or > ECTO1.06.
1.08	Compr_1_Low_Temp_Lockout	81 80	255 -31	254 -30	Counts Y: Deg.	Low ambient lockout for compressor 1. 254 value equals -30 °F (-34°C). A value of 255 (-31°F) will disable low ambient lockout function. Note: This lockout is for heating only. Temperature must be < or = 1.09.
1.09	Compr_2_Low_Temp_Lockout	81 80	255 -31	254 -30	Counts Y: Deg.	Low ambient lockout for compressor 2. 254 value equals -30 °F (-34°C). A value of 255 (-31°F) will disable low ambient lockout function. Note: This lockout is for heating only. Temperature must be > or = 1.08.
1.10	Compr_Min_Off_Delay	30 60	150 300	255 510	Counts A:Sec	Compressor minimum off delay. Used on 1 PH units. Also used on all units after an alarm occurs.
1.11	Compr_Min_Run_Time	30 60	120 240	255 510	Counts A:Sec	Compressor minimum run time. Used on 3 PH units.
1.12	Max_HP_Occurrences	1	3	8	Counts	Maximum High Pressure occurrences stored before control locks off compressor stage and energizes the service output. If max value is set, lock-out and service output features are disabled.
1.13	Max_LP_Occurrences	1	3	8	Counts	Maximum Low Pressure occurrences stored before control locks off compressor stage and energizes the service output. If max value is set, lock-out and service output features are disabled.
1.14	Defrost_Sup_HT_Option	0	1	1	Option	Defrost options: 0: No supplemental heating during defrost. 1: Supplemental heating on during defrost.
1.15	Min_Time_Between_De-frost	1	2	3	Option	Minimum time allowed between defrost cycles. 1= 32 minutes 2= 64 minutes 3=96 minutes
1.16	Max_Defrost_Time	2 10	3 15	5 25	Counts Min	Maximum defrost time allowed.
1.17	WmUp_Option	0	0	2	Option	Warm-up mode option. 0- Supplemental heat may be used during warm-up. Use depends on outdoor temperature. See ECTO 1.06 and 1.07. 1- For the first demand cycle, lockout supplemental heat for the first 30 minutes (default). Time is adjustable by changing the parameter WARM-UP DLY # 1.01. 2- For future use.
1.18	Sup_HT_1_Diff	0 0	8 2	15 3.75	Counts W:DegF	Supplemental heat stage 1 differential. Used in zone sensor applications. Note: Differential temperature must be = to or < ECTO 1.19.
1.19	Sup_HT_2_Diff	0 0	12 3	15 3.75	Counts W:DegF	Supplemental heat stage 2 differential. Used in zone sensor applications. Note: Differential temperature must be = to or > ECTO 1.18
1.20	Sup_HT_1_Latch_Option	0	0	1	Option	Supplemental heat stage 1 latch option. Used in zone sensor applications. 0: Latch Disabled 1: Latch Enabled
1.21	Sup_HT_2_Latch_Option	0	0	1	Option	Supplemental heat stage 2 latch option. Used in zone sensor applications. 0: Latch Disabled 1: Latch Enabled

table continued on next page

Control Parameter		Control Value			Units	Description
No.	Name	Min.	Default	Max.		
Block 1 Heat Pump Heating Parameters (continued)						
1.22	Sup_HT_1_StgUp_Timer	0 0	0 0	225 3600	Counts F:Sec	Supplemental heat stage 1 stage-up timer. The maximum time that stage 1 runs before calling supplemental heat stage 1. Used in zone sensor applications. Disabled if set to 0.
1.23	Sup_HT_2_StgUp_Timer	0 0	0 0	225 3600	Counts F:Sec.	Supplemental heat stage 2 stage-up timer. The maximum time that supplemental heat 1 runs before calling supplemental heat stage 2. Used in zone sensor applications. Disabled if set to 0.
1.24	StgDn_Timer	0 0	19 304	225 3600	Counts F:Sec	Time delay before a lower stage turns off following a higher stage termination. Used in zone sensor applications.
1.25	Heat Pump Type	0	0	1	Option	0: Air Source Heat Pump 1: Reserved
Block 2 Electric Heating Parameters						
2.01	WmUp_Delay	0 0	112 3584	255 8160	Counts D:Sec	Warm-up time delay. The time that the economizer is forced closed during warm-up (first occupied + heat demand)
2.02	BL_On_Delay	0 0	0 0	0 0	Counts B:Secs	Blower on delay. The time before the blower turns on after a heating demand. Reserved for future use
2.03	BL_Off_Delay	0 0	5 20	75 300	Counts B:Secs	Blower off delay. The time the blower stays on after the heating demand is lost.
2.04	Max_HT_LT_Occurrences	1	3	15	Counts	Service output activation. Maximum Primary and Secondary Limit occurrences stored before service relay is energized. If max value is set, service output is disabled. Note: Heating stage is not locked out
2.05	HT_Stg_Delay	3 12	3 12	15 60	Counts B:Secs	Time delay between heat stages.
2.06	Stg_Latch_Option	0	0	1	Option	Stage latch option. Used in zone sensor applications. 0: Latch Disabled 1: Latch Enabled
2.07	StgUp_Timer	0 0	57 912	225 3600	Counts F:Sec	Stage up timer. The maximum time that lower stage runs before calling next heat stage. Used in zone sensor applications. Disabled if set to 0.
2.08	StgDn_Timer	0 0	0 0	225 3600	Counts F: Sec	Time delay before a lower stage turns off following a higher stage termination. Used in zone sensor applications.
Block 3 Gas Heating Parameters						
3.01	WmUp_Delay	0 0	112 3584	255 8160	Counts D: Sec.	Warm-up time delay. The time that the economizer is forced closed during warm-up (first occupied + heat demand) .
3.02	BL_On_Delay	2 8	10 40	15 60	Counts B: Sec.	Blower on delay. The time before the blower turns on after a heating demand.
3.03	BL_Off_Delay	20 80	30 120	75 300	Counts B:Sec.	Blower off delay. The time the blower stays on after the heating demand is lost.
3.04	Max_Ht_LT_Occurrences	1	3	15	Counts	Service relay activation. Maximum Primary and Secondary Limit occurrences stored before service relay is energized. If max value is set, service output is disabled. Note: Heating stage is not locked out.
3.05	High_Fire_Delay	15 30	15 30	150 300	Counts A:Sec.	The minimum low fire time before high fire is allowed.
3.06	HT_Off_Delay	15 30	50 100	150 300	Counts A:Sec.	Heating off delay.
3.07	Max_CAI_Proof_Switch_Occurrences	1	3	6	Counts	Service relay activation. Maximum Combustion Air Inducer proof switch occurrences stored before service output is energized. If max value is set, service output is disabled. Note: Heating stage is not locked out.
3.08	Max_Roll_Out_Switch_Occurrences	1	1	4	Counts	Service output activation. Maximum Roll Out Switch occurrences stored before service relay is energized. If max value is set, service output disabled. Note: Heating stage is not locked out.
3.09	Max_GV_Sense_Occurrences	1	3	6	Counts	Service output activation. Maximum Gas Valve Sense occurrences stored before service output is energized. If max value is set, service output is disabled. Note: Heating stage is not locked out.
3.10	Stg_Latch_Option	0	0	1	Option	Stage latch option. Used in zone sensor applications. 0: Latch Disabled 1: Latch Enabled
3.11	StgUp_Timer	0 0	57 912	225 3600	Counts F: Sec	Stage-up timer. The maximum time that lower stage runs before calling next heat stage. Used in zone sensor applications. Disabled if set to 0.

table continued on next page

Control Parameter		Control Value			Units	Description
No.	Name	Min.	Default	Max.		
Block 3 Gas Heating Parameters (continued)						
3.12	StgDn_Timer	0 0	0 0	225 3600	Counts F: Sec	Time delay before a lower stage turns off following a higher stage termination. Used in zone sensor applications.
3.13	MGV_Control_Mode	0	0	6	Option	<p>Modulating Gas Valve Mode</p> <p>0- A133 (GP1) not installed.</p> <p>1- A133 (GP1 w/DIP set to MGVS) installed, but no MGVS. Data logging only.</p> <p>2- Two-stage fire; min. or 100% (with or without low-fire FAH)</p> <p>3- 2 + modulating FAH</p> <p>4- Direct mode.</p> <p>AI1 (A133_P194-11) scaled to 0-100% and output on AO1.</p> <p>AI2 (A133_P194_12) scaled to 0-100% and output on AO2.</p> <p>5- DACH control; min. to maximum (with or without lo-fire FAH)</p> <p>6- 5 + modulating FAH</p> <p>Lighting sequence is followed for all modes; 2-6. See ECTO 3.14 and 3.15.</p>
3.14	MGV_startup_Phase2_delay	2 4	8 16	150 300	Counts A: Sec.	Modulating gas startup delay. At startup, run burners on low stage main gas valve(s) with MGVS(s) at 100% for ECTO 3.05 seconds. Increase burners to high stage of main gas valve(s) with MGVS(s) opened to ECTO 3.15 for ECTO 3.14 seconds. Begin PID or staged control of MGVS(s).
3.15	MGV_Max	60 60	80 80	100 100	Counts P:%	Modulating gas valve maximum.
3.16	MGV_Min	0 0	20 20	100 100	Counts P:%	Modulating gas valve minimum.
3.17	MGV_PID_ManRS	0 0	50 50	100 100	Counts P:%	Modulating gas valve PID manual reset value.
3.18	MGV_PID_P_Constant	0	40	127	Counts	Modulating gas valve PID proportional constant.
3.19	MGV_PID_I_Constant	0	0	127	Counts	Modulating gas valve PID integral constant.
3.20	MGV_PID_D_Constant	0	0	127	Counts	Modulating gas valve PID derivative constant.

table continued on next page

Control Parameter		Control Value			Units	Description
No.	Name	Min.	Default	Max.		
Block 3 Gas Heating Parameters (continued)						
3.21	DO_Mode_A133 (MGV mode)	0	0	127	Option	<p>GP1 Digital Out Mode = X + 32*Y + 16*Z Input source= X: 0- None. 1- Compressor 1 duty cycle. (Compressor crankcase heater function.) On when OAT <= ECTO 3.22 and >= ECTO 3.23 seconds have passed with compressor 1 off. Off when OAT > ECTO3.22 + 3°F (fixed dead-band) or < ECTO 3.23 sec have passed with compressor 1 off 2- On when occupied. 3- On when blower on, 4- On when heating demand. 5- On when cooling demand. 6- On when heating or cooling demand. 7- System RH (A55_P298_5 RH) 8- System IAQ. (A55_P298_3 IAQ) 9- System OAT (A55_P267_1/2 OAT) 7- System RH (Either A55_P114-10 or network RH) 11- AI2 (A133_P194-7) (SP and DB set with ECTO3.22 & 3.23) 12- AI3 (A133_P194-8) (SP and DB set with ECTO3.22 & 3.23) 13- AI4 (A133_P194-9) (SP and DB set with ECTO3.22 & 3.23) 14- AO1 (A133_P194-11) 15- AO2 (A133_P194-12)</p> <p>Algorithm Y for input sources 7-15: 0- Hysteresis loop On when input >= ECTO 3.22 Off when input < ECTO 3.22-ECTO 3.23</p>  <p>1—Window On when input is in range; >= ECTO 3.22 and <= ECTO 3.22 + ECTO 3.23 (Fixed 3-count hysteresis loop on rising and falling edges of window.)</p>  <p>2- Delayed-on. On when input is >= ECTO 3.22 for >= ECTO 3.23 seconds. Off when input is < ECTO 3.22 - 3. (Fixed 3-count hysteresis loop on edge.)</p>  <p>3- Delayed-off. On when input is >= ECTO 3.22. Off when input is < ECTO 3.22 -3 for >= ECTO 3.23 seconds. (Fixed 3-count hysteresis loop on edge.)</p>  <p>Inversion Z: 0 - Output not inverted. 1 - Output inverted.</p> <p>Graphs indicate output not inverted. See figure 33.</p>
3.22	DO_SP_A133 (MGV mode)	0 0 0 132 -0.5 0	127 5.0 996 100 51 0 2.5	255 10.0 2000 100 -31 0.5 5.0	Counts R:Volts I:ppm P:% Y:DegF M:"w.c. N:"w.c.	A133 (w/DIP set to MGV) digital output mode set point
3.23	DO_DB_A133_(MGV mode)	2 0 16 2 1 64 0.01 0	13 .50 102 13 8 416 0.05 .25	255 10.0 2000 100 162 8160 1.0 5.0	Counts R:Volts I:ppm P:% O:DegF D:Sec. L:"w.c. N:"w.c.	A133 (w/DIP set to MGV) digital output mode dead-band or delay.

table continued on next page

Control Parameter		Control Value			Units	Description
No.	Name	Min.	Default	Max.		
Block 4 Cooling Parameters						
4.01	CoolDn_Delay	0 0	56 1792	255 8160	Counts D:Sec.	Cool down time delay. Time that Y2 is ignored during cool down period (when first occupied + cool demand) This delay is only used if an economizer is used and the outdoor air is suitable.
4.02	BL_On_Delay	0 0	0 0	15 60	Counts B:Sec.	Blower on delay. The time before the blower turns on after a cooling demand.
4.03	BL_Off_Delay	0 0	0 0	60 240	Counts B:Sec.	Blower off delay. The time the blower stays on after the cooling demand is lost.
4.04	Max_Frz_Stat_Occurrences	1	3	5	Counts	Service output activation and compressor lockout. Maximum Freeze Stat occurrences stored before service relay is energized and compressor is locked-out. If value (4 or 5) is set, service output is disabled and compressor is not locked-out. If value 5 is set, alarms are not stored, but only displayed as they occur.
4.05	Cond_Fan_ReStart_Delay	0 0	3 6	8 16	Counts A:Sec.	Low ambient anti-windmilling condenser fan delay. The time period that the last operating fan is turned off before starting the next fan.
4.06	LAC_SP_Temp_1	113 60	144 40	191 10	Counts Y:DegF	Low ambient outdoor air limit temp. 1. Parameters 4.06 and 4.07 are used to shed fans. See Operation section. Temperature setting must be < or = 4.07.
4.07	LAC_SP_Temp_2	113 60	120 55	191 10	Counts Y:DegF	Low ambient outdoor air limit temp. 2. Parameters 4.06 and 4.07 are used to shed fans. See Operation section. Temperature setting must be > or = 4.06.
4.08	Compr_1_Low_Temp_Lockout	81 80	207 0	255 -31	Counts Y:DegF	Low ambient lockout for compressor 1. A value of 255 (-31°F) will disable low ambient lockout function. Temperature setting must be < or = 4.09.
4.09	Compr_2_Low_Temp_Lockout	81 80	207 0	255 -31	Counts Y:DegF	Low ambient lockout for compressor 2. A value of 255 (-31F) will disable low ambient lockout function. Temperature setting must be > or = 4.08 AND < or = 4.10.
4.10	Compr_3_Low_Temp_Lockout	81 80	207 0	255 -31	Counts Y:DegF	Low ambient lockout for compressor 3. A value of 255(-31F) will disable low ambient lockout function. Temperature setting must be > or = 4.09 AND < or = 4.11.
4.11	Compr_4_Low_Temp_Lockout	81 80	207 0	255 -31	Counts Y:DegF	Low ambient lockout for compressor 4. A value of 255 (-31F) will disable low ambient lockout function. Temperature setting must be > or = 4.10.
4.12	Compr_Min_Off_Delay	30 60	150 300	255 510	Counts A:Sec.	Compressor minimum off delay. Used on 1 PH units.
4.13	Compr_Min_Run_Time	30 60	120 240	255 510	Counts A:Sec.	Compressor minimum run time. Used on 3 PH units.
4.14	Max_HP_Occurrences	1	3	8	Counts	Maximum High Pressure occurrences that are stored before control locks off compressor stage and energizes the service output. If max value is set, lockout and service output features are disabled.
4.15	Max_LP_Occurrences	1	3	8	Counts	Maximum Low Pressure occurrences that are stored before control locks off compressor stage and energizes the service relay. If max value is set, lockout and service output features are disabled.
4.16	Cond_Fan_Delay	0 0	1 2	120 240	Counts A:Sec.	Condenser fan delay. Used only on 6 fan units.
4.17	Stg_2_Latch	0	0	1	Option	Stage 2 latch option. Used in zone sensor applications. 0: Latch Disabled 1: Latch Enabled
4.18	Stg_3_Latch	0	0	1	Option	Stage 3 latch option. Used in zone sensor applications. 0: Latch Disabled 1: Latch Enabled
4.19	Stg_4_Latch	0	0	1	Option	Stage 4 latch option. Used in zone sensor applications. 0: Latch Disabled 1: Latch Enabled
4.20	Stg_2_StgUp_Timer	0 0	57 912	225 3600	Counts F:Sec	Stage 2 stage up timer. The maximum time that cooling stage 1 runs before calling cooling stage 2. Used in zone sensor applications. Disabled if set to 0.
4.21	Stg_3_StgUp_Timer	0 0	57 912	225 3600	Counts F:Sec	Stage 3 stage up timer. The maximum time that cooling stage 2 runs before calling cooling stage 3. Used in zone sensor applications. Disabled if set to 0.

table continued on next page

Control Parameter		Control Value			Units	Description
No.	Name	Min.	Default	Max.		
4.22	Stg_4_StgUp_Timer	0 0	57 912	225 3600	Counts F:Sec	Stage 4 stage up timer. The maximum time that cooling stage 3 runs before calling cooling stage 4. Used in zone sensor applications. Disabled if set to 0.
4.23	StgDn_Timer	0 0	57 912	225 3600	Counts F:Sec	Time delay before a lower stage turns off following a higher stage termination. Used in zone sensor applications.

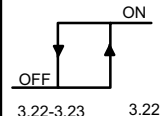
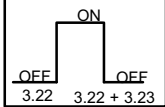
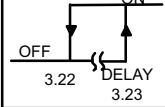
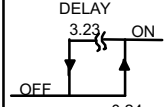
table continued on next page

Control Parameter		Control Value			Units	Description
No.	Name	Min.	Default	Max.		
Block 4 Cooling Parameters (continued)						
4.24	Reheat_Control	0	0	7	Option	<p>Reheat Control Mode</p> <ul style="list-style-type: none"> 0- No reheat. 1- Supermarket reheat using De-Humidistat (Tstat mode only) 2- Supermarket reheat using RH sensor. 3- Humiditrol reheat. Conditions: Blower must be energized, Must be occupied, At least one previous cooling demand. 4- RH measurement / display. No Supermarket or Humiditrol reheat. 5- Humiditrol reheat. Conditions: At least one previous cooling demand. 6- Humiditrol reheat. Conditions: Blower must be energized, Must be occupied. 7- Humiditrol reheat. Conditions: None
4.25	Reheat_SP	0 0	60 60	100 100	Counts P:%RH	<p>Percent relative humidity where supermarket or Humiditrol reheat demand is energized. Used of Reheat option 2,3,5,6,or 7. Reheat is de-energized at set point – dead-band (ECTO 4.26).</p> <p>If value = 100, Humiditrol reheat is controlled by the digital input A55_P299-8 Digital Input 4 only. Energized input signal calls for reheat demand.</p> <p>L Connection Network RH set point will override this set point. (Such as from NCP).</p> 
4.26	Reheat_RH_DB	1 1	3 3	10 10	Counts P:%RH	<p>Reheat RH dead-band.</p> <p>Used of Reheat option 2,3,5,6,or 7. Reheat is on when RH>=ECTO 4.25 and off when RH< ECTO 4.25 – ECTO 4.26.</p>
4.27	FC_LAL_SP	81 80	120 55	136 45	Counts Y:DegF	<p>Free-cooling Low Ambient Lockout Set point.</p> <p>When outdoor air is suitable for free cooling and an economizer is present, the compressor will not run when ambient is below this value. A value of 207 (0 degF) disables this feature. A value of 81 (80 degF) locks out compressor operation whenever OAS, regardless of OAT.</p>
Block 5 Miscellaneous Parameters						
5.01	SMK_Alarm	0	0	7	Option	<p>Smoke alarm control options.</p> <ul style="list-style-type: none"> 0- Unit off. 1- Blower on, exhaust fan off, OD air damper open (positive pressure) 2- Blower on, exhaust fan on, OD air damper closed (negative pressure). On VAV units, exhaust fan will run at speed set in ECTO 8.19 with blower). 3- Blower on, exhaust fan on, OD air damper open (purge). On VAV units, exhaust fan will run at speed set in ECTO 8.19. 4- Blower off, exhaust fan on, OD air damper closed (negative pressure). On VAV units, exhaust fan will run at speed set in ECTO 8.19. 5- Blower on, exhaust fan on, OD air damper closed (negative pressure). On VAV units, exhaust fan will run to maintain pressure set point set in ECTO 8.19 with blower). 6- Blower on, exhaust fan on, OD air damper open (purge). On VAV units, exhaust fan will run to maintain pressure set point set in ECTO 8.19. 7- Blower off, exhaust fan on, OD air damper closed (negative pressure). On VAV units, exhaust fan will run to maintain pressure set point set in ECTO 8.19.
5.02	Error_Timed_Off_Delay	8 64	38 304	225 1800	Counts C:Sec.	<p>Off time delay if a "no-run" error occurs. Off delay for error codes 5, 10, 11, 20, 21, 44, 45, 83, 86, 87 and 114.</p>
5.03	Display_Temp	0	0	1	Option	<p>Degrees Celsius option for A55 Display</p> <ul style="list-style-type: none"> 0: Displays degrees Fahrenheit 1: Displays degrees Celsius

table continued on next page

Control Parameter		Control Value			Units	Description
No.	Name	Min.	Default	Max.		
Block 5 Miscellaneous Parameters (continued)						
5.04	CL_Staging	0	2	4	Option	Cooling staging options: 0- No cooling operation 1- Basic Tstat operation. Two cooling stages. Units with Economizers Y1=Free Cooling, Y2=adds all mechanical stages. 2- Basic Tstat operation. Two cooling stages. Units with Economizers Y1=Free Cooling, Y2= adds first stage of mechanical. 3- Basic Tstat operation. Three cooling stages. Y1 only = first stage, Y2 only = second stage, Y1+Y2 = third stage. Units with Economizers Y2 only adds first stage of mechanical, Y1+Y2 adds first and second stage of mechanical. 4- Discharge air control. Up to four stages.
5.05	RAT_LT	0	0	1	Option	Enables return air temperature limit option. Return air limits may be used for limiting zone temperatures. Continuous fan operation recommended.
5.06	RAT_HT_LT	95 100	117 85	154 60	Counts X:DegF	Return air limit for heating. If the return air heating limit is exceeded, the heating demands are interrupted. 5.05 MUST BE SET TO 1 TO ENABLE
5.07	RAT_CL_LT	124 80	146 65	154 60	Counts X:DegF	Return air limit for cooling. If the return air cooling limit is exceeded, the cooling demands are interrupted. 5.05 MUST BE SET TO 1 TO ENABLE
5.08	A42_Input_Occurrences	1	3	15	Counts	A42 input occurrences before service relay is energized. (A55_P299_6)
5.09	HT_Staging	0	2	2	Option	Heating staging options: 0- No heating operation. 1- Discharge air control with up to 4 stages. 2- Thermostat operation.
5.10	LP_Strike_3_Run_Time_1	0 0	45 360	255 2040	Counts C:Sec.	Ignore LP trip when compressor run time less than this. LONG/HOT condition.
5.11	LP_Strike_3_Run_Time_2	0 0	90 720	255 2040	Counts C: Sec.	Ignore LP trip when compressor run time less than this. LONG/COLD condition.
5.12	LP_Strike_3_Run_Time_3	0 0	15 120	255 2040	Counts C:Sec.	Ignore LP trip when compressor run time less than this. SHORT/HOT condition.
5.13	LP_Strike_3_Run_Time_4	0 0	38 304	255 2040	Counts C:Sec.	Ignore LP trip when compressor run time less than this. SHORT/COLD condition.
5.14	LP_Strike_3_Off_Time	28 3584	113 14464	169 21632	Counts E:Sec	Low Pressure Switch Strike Three compressor off time break point for LONG/SHORT evaluation.
5.15	LP_Strike_3_Temp_SP	50 100	97 70	191 10	Counts Y:Deg.	Low Pressure Switch Strike Three outdoor air temperature break point for HOT/COLD evaluation.
5.16	DCV_Max_Damper_Open	0 0	100 100	100 100	Counts P:%	Maximum allowed Demand Control Ventilation damper open position. (Set to 0 to disable IAQ). Also used for OAC.
5.17	DCV_Damper_Start_Open_SP	0 0	64 502	255 2000	Count I:PPM	Damper "start open" CO ₂ set point for Demand Control Ventilation. Level where fresh air damper begins to open.
	OAC_Dampr_Start_Open_SP	0	2.51	10	R: Volt	Damper "start open" set point for Outdoor Air Control. Level where fresh air damper begins to open.
5.18	DCV_Dampr_Full_Open_SP	0 0	128 1004	255 2000	Count I:PPM	Damper "full open" CO ₂ set point for Demand Control Ventilation. Level where fresh air damper is opened to maximum.
	OAC_Dampr_Full_Open_SP	0	5.02	10	R: Volt	Damper "full open" set point for Outdoor Air Control. Level where fresh air damper is opened to maximum.
5.19	DCV_Low_Temp_Override_Full_Closed	0 132	191 10	255 -31	Counts Y:Deg.F	Low outdoor air temp. where fresh air damper is closed to minimum position for Demand Control Ventilation and Outdoor Air Control (OAC).
5.20	DCV_Low_Temp_Override_Start_Closing	0 132	144 40	255 -31	Counts Y:Deg.F	Low outdoor air temp. where fresh air damper begins to close. Set ECTO 5.20 = 255 to disable the outdoor Low Temp. override of DCV operation. Also used for OAC.
5.21	DCV_HighTemp_Override_Start_Closing	0 132	89 75	255 -31	Counts Y:Deg.F	High outdoor air temp. where fresh air damper begins to close. Set 5.21 =0 to disable the outdoor High Temp override of DCV operation. Also used for OAC.
5.22	DCV_High_Temp_Override_Full_Close	0 132	42 105	255 -31	Counts Y:Deg.F	High outdoor air temp. where fresh air damper is closed to minimum position. Also used for OAC.
5.23	Free_CL_Max_Damper	0 0	100 100	100 100	Counts P:%	The maximum allowed fresh air damper opening for FREE COOLING.

table continued on next page

Control Parameter		Control Value			Units	Description
No.	Name	Min.	Default	Max.		
Block 5 Miscellaneous Parameters (continued)						
5.24	Min_Damper_Position	0 0	101 101	100 100	Counts P: %	Minimum fresh air damper position during occupied operation. Value of 101 allows adjustment by potentiometer on economizer board A55 only. When in global mode with A55 EM1 versions 2.01 and earlier, only 101 should be used.
5.25	Zone_Sensor_StartUp_Delay	15 2	15 2	225 30	Counts C:Min.	Start-up demand delay. Holds off all unit operation zone sensor and CAVB applications. Hold off FAH-Reheat, FAC, FAH options and all GP outputs. May be used to stagger unit start-ups. Does NOT delay demands in thermostat mode.
5.26	IAQ_Input_Source/Mode	0	0	5	Option	IAQ input source and mode (0-3 operate only when blower is on). 0- DCV System IAQ. Either P298-3 or network IAQ. 1- DCV System IAQ. Either P298-3 or network IAQ with no OAT limits. 2- Outdoor Air Control Sensor A24 (A133_P194-6) (TB22-6). 3- Outdoor Air Control Sensor A24 (A133_P194-6) (TB22-6) with no OAT limits. 4- DCV System IAQ. Either P298-3 or network IAQ with blower on/auto operation. 5- DCV System IAQ. Either P298-3 or network IAQ with blower on/auto operation with no OAT limits.
5.27	Net_Sig_Sources	0	0	15	Option	Network Signal Sources Weight Description 1- IAQ (A63) 2- Zone Temp. (A2) 4- Outdoor Enthalpy (A7) 8- Indoor RH (A91) Option is sum of the weights for all input signals that are provided remotely over the network. Note: When network sensor is used the physical analog input is ignored. Loss of sensor alarms will not occur unless network communication is lost for 5 minutes, or has not been established within 5 minutes after reset.
Block 6 System 1 Parameters						
6.01	System_Mode	0	0	12	Option	System mode of operation. Control Value System Mode Backup Mode 0- Local Thermostat None 1- Zone Sensor None 2- Zone Sensor Local Thermostat 3- Zone Sensor Return Air Sensor 4- Remote Demand None 5- Remote Demand Local Thermostat 6- Remote Demand Return Air Sensor 7- Remote Demand Zone Sensor
6.02	Ocp_HT_BkUp_SP	20 95	120 70	240 40	Counts Z:DegF	Backup occupied heating set point. Used if the communications link is lost for 5 minutes between the M2 and NCP. Used only with zone sensor applications. Set point temperature must be < or = (6.04 - 6.15).
6.03	UnOcp_HT_BkUp_SP	20 95	160 60	240 40	Counts Z:DegF	Backup unoccupied heating set point. Used if the communications link is lost for 5 minutes between the M2 and NCP. Used only in zone sensor applications. Set point temperature must be < or = (6.05 - 6.15).
6.04	Ocp_CL_BkUp_SP	20 95	100 75	240 40	Counts Z:DegF	Backup occupied cooling set point. Used if the communications link is lost for 5 minutes between the M2 and NCP. Used only in zone sensor applications. Set point temperature must be > or = (6.02 + 6.15).
6.05	UnOcp_CL_BkUp_SP	20 95	60 85	240 40	Counts Z:DegF	Backup unoccupied cooling set point. Used if the communications link is lost for 5 minutes between the M2 and NCP. Used only in zone sensor applications. Set point temperature must be > or = (6.03 + 6.15).
6.06	Override_Timer	0 0	28 3584	225 28800	Counts E: Sec	After hours override timer. Only used on zone sensor applications without a Network Control Panel (NCP).
6.07	HT_Stg_DB	4 1	4 1	15 3.75	Counts W:DegF	Heating dead-band. Used only with M2 zone sensor applications. Dead band must be < or = 6.15 - 6.08.

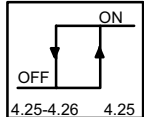
table continued on next page

Control Parameter No.	Control Parameter Name	Control Value			Units	Description
		Min.	Default	Max.		
Block 6 System 1 Parameters (continued)						
6.08	CL_Stg_DB	4 1	4 1	15 3.75	Counts W:DegF	Cooling dead-band. Used only with zone sensor applications. Dead band must be < or = 6.15 - 6.07.
6.09	Stg_1_HT_Dif	0 0	2 0.5	12 3	Counts W:DegF	Heating stage 1 differential. Used only with zone sensor applications. Differential temperature must be < or = 6.11.
6.10	Stg_1_CL_Dif	0 0	2 0.5	12 3	Counts W:DegF	Cooling stage 1 differential. Used only with zone sensor applications. Differential temperature must be < or = 6.12.
6.11	Stg_2_HT_Dif	0 0	4 1	12 3	Counts W:DegF	Heating stage 2 differential. Used only with zone sensor applications. Differential temperature must be > or = 6.09.
6.12	Stg_2_CL_Dif	0 0	4 1	12 3	Counts W:DegF	Cooling stage 2 differential. Used only with zone sensor applications. Differential temperature must be > or = 6.10 AND < or = 6.13.
6.13	Stg_3_CL_Dif	0 0	6 1.5	12 3	Counts W:DegF	Cooling stage 3 differential. Used only with zone sensor applications. Differential temperature must be > or = 6.12 AND < or = 6.14.
6.14	Stg_4_CL_Dif	0 0	8 2	12 3	Counts W:DegF	Cooling stage 4 differential. Used only with zone sensor applications. Differential temperature must be > or = 6.13.
6.15	Zone_Sensor Autochangeover DB_Min	8 2	12 3	40 10	Counts W:DegF	Minimum autochangeover dead-band temperature. Dead band must be > or = (6.07 + 6.08). Used in zone sensor applications.
6.16	Autochangeover _Delay	15 60	75 300	225 900	Counts B: Sec	Autochangeover time delay. Delay between heating and cooling modes.
6.17	BL_Con- trolZone_Senso r	0	0	1	Option	Blower control option for zone sensor applications during occupied periods. 0 = Blower cycles with demands 1 = Continuous blower
6.18	Zone_Sensor_ Calibration	-20 -5	0 0	20 5	Counts W:DegF	Zone sensor calibration offset. Counts: -20 -16 -12 -8 -4 0 4 8 12 16 20 Offset(°F)-5 -4 -3 -2 -1 0 1 2 3 4 5 °F is an offset added to the zone sensor reading. Example: If the zone sensor is reading 2°F high, it can be corrected by setting the count value to -8 (-2°F offset).
6.19	Free_CL_Lock- out_SP	112 60	161 Disabled	160 30	Counts Y:DegF	Free cooling lockout SP. Locks out free cooling when outdoor temperature is below this value. Default value 161 disables free cooling lockout.
6.20	FAH_SP	139 70	138 Disabled	183 40	Counts X:DegF	Fresh Air Heating set point. To enable FAH, set this to a value between 40F (183) and 70F(139). Minimum value (138) disables Fresh Air Heating.
6.21	FAH_Stg_DB	5 3	15 10	22 15	Counts V:DegF	Fresh Air Heating stage dead-band.
6.22	FAH_Min_ Cycle_Time	15 120	60 480	225 1800	Counts C:Sec	Fresh Air heating minimum cycle time.
6.23	Free_Cooling_ Supply_SP	146 65	161 55	176 45	Counts X:Deg.F	Economizer modulates dampers to maintain supply air temperature (RT6) at this set point during free cooling. DACC reset applies. See ECTO 8.01-8.07.
6.24	Stg_3_HT_Dif	0 0	6 1.5	12 3	Counts W:DegF	Heating stage 3 differential temperature. Used only with zone sensor applications. Differential temperature must >= ECTO 6.11.
6.25	Stg_4_HT_Dif	0 0	8 2	12 3	Counts W:DegF	Heating stage 4 differential temperature. Used only with zone sensor applications. Differential temperature must >= ECTO 6.24.
6.26	Economizer_ Free_CL_SP	97 70	191 10	2507 0	Counts Y:DegF	A55 DIP switch selects temperature (TMP) or enthalpy (ODE) mode. When in TMP mode, outdoor air is suitable for free-cooling when OAT < ECTO for ECTO 41-70 degF, or when OAT < RAT - ECTO for ECTO 0-40 degF. This ECTO is not used in ODE mode. OAT = OUTDOOR TEMPERATURE RAT=RETURN TEMPERATURE
6.27	Economizer_ Profile	0	2	2	Option	Economizer operating profile during free cooling when compressor cooling is on. 0 - Damper continues to modulate. 1 - Damper opens to ECTO 5.23. 2 - Same as 1, but additionally holds off compressor cooling until the damper has modulated to ECTO 5.23 value for 3 minutes.

table continued on next page

Control Parameter No.	Control Parameter Name	Control Value			Units	Description
		Min.	Default	Max.		
Block 7 System 2 Parameters						
7.01	FAH_Stg_Diff	0 0	3 2	30 20	Counts V:DegF	Fresh Air Heating stage differential. 0 value for first stage heating only for Fresh Air Heating.
7.02	Reheat_FAH_OAT_SP	113 60	136 45	175 20	Counts Y:DegF	Outdoor air temperature set point that enables fresh air heating for reheat demand and opens damper to ECTO 7.03 when outdoor air is less than set point.
7.03	Reheat_FAH_%_Damper	5 5	40 40	100 100	Counts P:%	Fresh air damper position during Fresh Air Heating reheat operation.
7.04	Reheat_FAH_SP	139 70	138 Disabled	183 40	Counts X:DegF	Fresh Air Heating Reheat set point. Minimum value of 138 disables FAH-Reheat.
7.05	FAT_Autochange_Delay	28 896	56 1792	225 7200	Counts D: Sec.	Fresh air Tempering (FAH or FAC) auto-changeover delay.
7.06	FAC_SP	109 90	108 Disabled	154 60	Counts X:DegF	Fresh Air Cooling set point. To enable FAC, set this to a value between 60°F (154) and 90°F(109). Minimum value of 91°F (108) disables FAC.
7.07	FAC_Stg_DB	5 3	15 10	22 15	Counts V:DegF	Fresh Air Cooling stage dead-band.
7.08	FAC_Min_Cycle	15 120	60 480	225 1800	Counts C: Sec.	Fresh Air Cooling minimum cycle time.
7.09	FAC_Stg_Diff	0 0	3 2	30 20	Counts V:DegF	Fresh Air Cooling stage differential between stages. Set to 0 for first stage cooling only for Fresh Air Cooling.
7.10	DACH_OCP_SP	36 140	80 110	154 60	Counts X:DegF	Discharge Air Control Heating set point during occupied period.
7.11	DACH_UnOCP_SP	36 140	95 100	154 60	Counts X:DegF	Discharge Air Control Heating set point during unoccupied period.
7.12	DACH_Stg_DB	7 5	7 5	30 20	Counts V:DegF	Discharge Air Control Heating dead-band.
7.13	DACH_&_FAH_StgUp_Delay	0 0	45 180	225 900	Counts B: Sec.	Discharge Air Control Heating and Fresh Air Heating stage-up time delay.
7.14	DACH_&_FAH_StgDn_Delay	0 0	30 120	150 600	Counts B: Sec.	Discharge Air Control Heating and Fresh Air Heating stage-down time delay.
7.15	DACH_Stg_Diff	3 2	3 2	30 20	Counts V:DegF	Discharge Air Control Heating stage differential
7.16	DACC_OCP_SP	95 100	161 55	183 40	Counts X:DegF	Discharge Air Control Cooling set point during occupied period.
7.17	DACC_UnOCP_SP	95 100	146 65	183 40	Counts X:DegF	Discharge Air Control Cooling set point during unoccupied period.
7.18	DACC_Stg_DB	7 5	7 5	30 20	Counts V:DegF	Discharge Air Control Cooling stage dead-band.
7.19	DACC_&_FAC_StgUp_Delay	0 0	45 180	225 900	Counts B: Sec.	Discharge Air Control Cooling and Fresh Air Cooling stage-up delay.
7.20	DACC_&_FAC_StgDn_Delay	0 0	30 120	150 600	Counts B: Sec.	Discharge Air Control Cooling and Fresh Air Cooling stage-down time delay.
7.21	DACC_Stg_Diff	3 2	3 2	30 20	Counts V:DegF	Discharge Air Cooling stage differential.

table continued on next page

Control Parameter		Control Value			Units	Description
No.	Name	Min.	Default	Max.		
Block 7 System 2 Parameters (continued)						
7.22	Service_ Output_ Control_Mode	0	0	127	Option	<p>A55 Service Output Control Mode = X + 32*Y + 16*Z Input source = X:</p> <p>0- None. Standard Service Output based on alarms. 1- Compressor 1 duty cycle. (Compressor crankcase heater function.) On when OAT <= ECTO 7.23 and >= ECTO 7.24 seconds have passed with compressor 1 off. Off when OAT > ECTO 7.23 + 3 deg F (fixed dead-band) or < ECTO 7.24 seconds have passed with compressor 1 off 2- On when occupied. 3- On when blower on, 4- On when heating demand. 5- On when cooling demand. 6- On when heating or cooling demand. 7- System RH (A55_P298_5 RH) 8- System IAQ. (A55_P298_3 IAQ) 9- System OAT (A55_P267_1/2 OAT) 10- Energy Recovery System (ERS) option. 11- SCR option for electric heat. DO-1 on with blower but off with cooling.</p> <p>Algorithm Y for input sources 7-9:</p> <p>0- Hysteresis loop On when input >= ECTO 7.23 Off when input < ECTO 7.23-ECTO 7.24</p>  <p>1- Window On when input is in range; >= ECTO 7.25 and <= ECTO 7.23 + ECTO 7.24 (Fixed 3-count hysteresis loop on rising and falling edges of window.)</p>  <p>2- Delayed-on On when input is >= ECTO 7.23 for >= ECTO 7.24 seconds. Off when input is < ECTO 7.23-3. (Fixed 3-count hysteresis loop on edge.)</p>  <p>3- Delayed-off On when input is >= ECTO 7.23. Off when input is < ECTO 7.23 - 3 for >= ECTO 7.24 seconds. (Fixed 3-count hysteresis loop on edge.)</p>  <p>Inversion Z: 0 - Output not inverted. 1 - Output inverted.</p> <p>Graphs indicate output not inverted. See figure 33.</p>
7.23	Service_ Output_SP	0 0 0 132	127 996 100 51	255 2000 100 -31	Counts I:ppm P: % Y:DegF	A55 service relay output set point.
7.24	Service_ Output_DB	2 16 2 1 64	13 102 13 8 416	255 2000 100 162 8160	Counts I:ppm P: % O:DegF D:Sec.	A55 service relay output dead-band or delay.

table continued on next page

Control Parameter		Control Value			Units	Description
No.	Name	Min.	Default	Max.		
Block 7 System 2 Parameters (continued)						
7.25	Load_Shed_Option	0	0	15	Option	<p>Load shedding option used to disable half of available mechanical cooling.</p> <p>Select the load shedding input signal source:</p> <p>0- No load shedding.</p> <p>1- Special case. Shed all compressors when DI-3 opens. M2 v7.07 and later.</p> <p>2- EM1 GLO (A55_P265-3) (economizer DIP NOT set to global mode).</p> <p>4- DI1 (A133_P194-1, DIP set to GP)</p> <p>6- DI2 (A133_P194-2, DIP set to GP)</p> <p>8- DI1 (A133_P194-1, DIP set to MG).</p> <p>10- DI2 (A133_P194-2, DIP set to MG).</p> <p>12- DI1 (A133_P194-1, DIP set to VAV)</p> <p>14- DI2 (A133_P194-2, DIP set to VAV)</p> <p>These options select load shedding that will round up (fractional compressors on).</p> <p>1 compressor unit – compressor is not disabled.</p> <p>3 compressor unit – only compressor 3 is disabled.</p> <p>Add one to any option to select load shedding that will round down (fractional compressors off).</p> <p>1 compressor unit – compressor is disabled.</p> <p>3 compressor unit – compressors 2 and 3 are disabled.</p>
7.26	BACnet_MAC	0	128	128	Address / Option	BACnet MAC Address. A value of 0-127 sets the BACnet MAC address to that value; 128 sets the MAC address to the unit address set on the ADDRESS DIP switch.
Block 8 System 3 Parameters						
8.01	DACC_RS_Total_LT	7 5	15 10	29 20	Counts V:DegF	Discharge Air Control Cooling total reset limit. This limits the total DACC reset allowed. Also used to reset free cooling set point (6.23).
8.02	DACC_RAT_RS_SP	124 80	139 70	169 50	Counts X:DegF	Discharge Air Control Cooling return air reset set point. Also used to reset free cooling set point (6.23).
8.03	DACC_RAT_RS_Proportional_Band	1 1	15 10	44 30	Counts V:DegF	Discharge Air Control Cooling return air reset proportional band. Also used to reset free cooling set point (6.23).
8.04	DACC_RAT_RS_Adjust_Band	0 0	0 0	44 30	Counts V:DegF	Discharge Air Control Cooling return air reset adjustment band. 0 disables return air cooling reset. Also used to reset free cooling set point (6.23).
8.05	DACC_OAT_RS_SP	50 100	81 80	144 40	Counts Y:DegF	Discharge Air Control Cooling outdoor air temperature cooling reset set point. Also used to reset free cooling set point (6.23).
8.06	DACC_OAT_RS_Proportional_Band	1 1	31 20	94 60	Counts O:DegF	Discharge Air Control Cooling outdoor ambient temperature cooling proportional band. Also used to reset free cooling set point (6.23).
8.07	DACC_OAT_RS_Adjust_Band	0 0	0 0	47 30	Counts O:DegF	Discharge Air Control Cooling outdoor temperature ambient cooling adjustment reset band. 0 disables outdoor air cooling reset. Also used to reset free cooling set point (6.23).
8.08	DACH_RS_Limit	7 5	15 10	29 20	Counts V:DegF	Discharge Air Control Heating reset limit. This limits the total DACH reset allowed.
8.09	DACH_RAT_RS_SP	124 80	139 70	169 50	Counts X:DegF	Discharge Air Control Heating return air heating reset set point.
8.10	DACH_RAT_RS_Proportional_Band	1 1	15 10	44 30	Counts V:DegF	Discharge Air Control Heating return air heating reset proportional band.
8.11	DACH_RAT_RS_Adjust_Band	0 0	0 0	44 30	Counts V:DegF	Discharge Air Control Heating return reset adjustment band. 0 value disables return air heating reset.
8.12	DACH_OAT_RS_SP	113 60	144 40	255 -31	Counts Y:DegF	Discharge Air Control Heating outdoor temperature reset set point.
8.13	DACH_OAT_RS_Proportional_Band	1 1	31 20	94 60	Counts O:DegF	Discharge Air Control Heating temperature reset proportional band.
8.14	DACH_OAT_RS_Adjust_Band	0 0	0 0	47 30	Counts O:DegF	Discharge Air Control Heating outdoor temperature reset adjustment band. 0 disables outdoor temperature heating reset

table continued on next page

Control Parameter		Control Value			Units	Description						
No.	Name	Min.	Default	Max.								
Block 8 System 3 Parameters (continued)												
8.15		0	0	255	Counts	Reserved.						
8.16	Exh_Fan_Control	0	0	23	Option	<p>Single stage (controlled by A55_P265-2 output)</p> <p>Mode Enable Input 1</p> <p>0- Blower D_POS</p> <p>1- Always A133_P194-1</p> <p>2- OCP A133_P194-1</p> <p>3- Blower A133_P194-1</p> <p>4- Always A133_P194-7</p> <p>5- Occupied A133_P194-7</p> <p>6- Blower A133_P194-7</p> <p>7- A133_P194-1 A133_P194-7</p> <div style="border: 1px solid black; padding: 2px; width: fit-content; margin-top: 5px;"> USE ECTO 8.20 AND 8.21 FOR SET POINT AND DEAD-BAND. USE ECTO 8.17 FOR 0-10VDC STAGE 1 OUTPUT IF A133 (VAV) PRESENT. </div> <p>Two stage exhaust fan (controlled by A55_P265-2 & A133_p194-5 outputs)</p> <p>Mode Enable Input 1 Input 2</p> <p>8- Blower D_POS D_POS</p> <p>9- Always A133_P194-1 A133_P194-2</p> <p>10- Occupied A133_P194-1 A133_P194-2</p> <p>11- Blower A133_P194-1 A133_P194-2</p> <p>12- Always A133_P194-7 A133_P194-7</p> <p>13- Occupied A133_P194-7 A133_P194-7</p> <p>14- Blower A133_P194-7 A133_P194-7</p> <p>15- A133_P194-1 A133_P194-7 A133_P194-7</p> <div style="border: 1px solid black; padding: 2px; width: fit-content; margin-top: 5px;"> USE ECTO 8.20-8.25 FOR STAGE SET POINTS, DEAD-BANDS AND STAGE DELAYS. USE ECTO 8.17 FOR 0-10VDC STAGE 1 OUTPUT. USE ECTO 8.18 FOR 0-10VDC STAGE 2 OUTPUT. </div> <p>For option 9-15, Stage 2 will not turn on until ECTO 8.25 seconds after stage 1. Stage 1 won't turn off until ECTO 8.22 seconds after stage 2 turns off.</p> <p>VFD (PID) controlled Exhaust Fan with on/off cycling at minimum speed (Cycled by A55_P265-2 and Speed controlled by VFD)</p> <p>Mode Enable Analog Input</p> <p>16 Always A133_P194-7</p> <p>17- Occupied A133_P194-7</p> <p>18- Blower A133_P194-7</p> <p>19- A133_P194-1 A133_P194-7</p> <div style="border: 1px solid black; padding: 2px; width: fit-content; margin-top: 5px;"> USE ECTO 8.19-8.25 FOR SET POINT AND PID CONSTANTS. </div> <p>Min. speed cycling: On at 10% over set point. Off after 30 seconds at minimum speed. Minimum 30 seconds off.</p> <p>VFD (PID) controlled Exhaust Fan (Always on when enabled) (Cycled by A55_P265-2 and Speed controlled by VFD)</p> <p>Mode Enable Analog Input</p> <p>20 Always A133_P194-7</p> <p>21 Occupied A133_P194-7</p> <p>22 Blower A133_P194-7</p> <p>23- A133_P194-1 A133_P194-7</p> <div style="border: 1px solid black; padding: 2px; width: fit-content; margin-top: 5px;"> USE ECTO 8.20-8.25 FOR SET POINT AND PID CONSTANTS. </div> <p>Always on at least minimum speed when enabled.</p>						
						8.17	Exh_Fan_Stg_1_SP	0 0	50 50	100 100	Counts P:%	Speed set point for stage 1 exhaust fan when using a VFD for controlling exhaust fan in staged mode.
						8.18	Exh_Fan_Stg_2_SP	0 0	100 100	100 100	Counts P:%	Speed set point for stage 2 exhaust fan when using a VFD for controlling exhaust fan in staged mode.
						8.19	Exh_Fan_SP_for_SMK	0 0.5	50 -0.3	255 0.5	Counts M:"w.c.	Exhaust fan smoke mode set point for PID option control
Staged_SMK	0	50	100	P:%	Staged set point for during smoke alarm. Value used depends on smoke mode (ECTO 5.01)							
8.20	Exh_Fan_SP	0 -0.5	50 -0.3	255 0.5	Counts M:"w.c.	Exhaust fan set point for PID option control						
	Stage_1_SP	0 -0.5	50 -0.3	100 0.5	P:% M:"w.c.	Stage 1 set point.						
8.21	Exh_Fan_Min	0 0	10 10	255 100	Counts P:%	Exhaust fan minimum speed.						
	Staged_1_DB	0 0	10 0.04	100 1.0	P:% L:"w.c.	Staged 1 dead-band.						
8.22	Exh_Fan_ManRS	0 0	50 50	100 100	Counts P: %	Exhaust fan PID loop manual reset value.						
	Stg_1_Off_Delay	0	100	200	A:Sec.	Stage 1 off-delay. (Only used for 2 stage operation)						
8.23	Exh_Fan_PID_P_Constant	0	20	255	Counts	Exhaust fan PID loop proportional constant. The P constant must be limited to 127. Recommended setting = 17.						

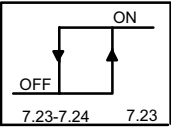
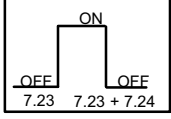
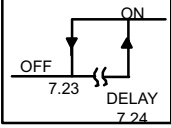
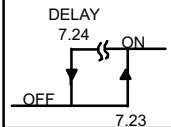
table continued on next page

Control Parameter		Control Value			Units	Description		
No.	Name	Min.	Default	Max.				
Block 8 System 3 Parameters (continued)								
	Stg_2_SP	0 0 -0.5	.78 20 -.42	10.0 100 0.5	R:Volts P:% M:"w.c.	Staged 2 set point.		
8.24	Exh_Fan_PID_I _Constant	0	64	255	Counts	Exhaust fan PID loop integral constant. The I constant must be limited to 127. Recommended setting = 12.		
	Stg_2_DB	0 0	64 0.25	100 1.0	P:% L:"w.c.	Staged 2 dead-band.		
8.25	Exh_Fan_PID_ D_Constant	0	0	127	Counts	Exhaust fan PID loop derivative constant.		
8.26	Unit_Run_Op- tions	0	1	1	Option	Add the weights for each control description to determine option. 1 - Occupied following reset until network command for OCP state is received.		
	Stg_2_On_ Delay	0	0	254	A: Sec.	Staged 2 on-delay.		
Block 9 Optional A133 Board in GP Mode (DIP switch set to GP) Parameters								
9.01	A01_control_ mode	0	0	11	Option	Analog output channel 1 control mode. 0 - No operation. Analog Output 1 off. <table style="width: 100%; border: none;"> <tr> <td style="width: 50%; vertical-align: top;">Enabled When 1- Occupied Unoccupied 2- Occupied Unoccupied 3- Occupied Unoccupied 4- Occupied Unoccupied 5- Blower On Blower Off 6- Blower On Blower Off 7- Blower On Blower Off 8- Blower On Blower Off 9 -DI2 (A133_P194-2) on DI1 (A133_P194-1) on Otherwise off 10-DI2 (A133_P194-2) on DI1 (A133_P194-1) on Otherwise off 11-DI2 (A133_P194-2) on DI1 (A133_P194-1) on Otherwise off (1) -DI1 (A133_P194-2) doesn't matter (2) -DI2 (A133_P194-1) is off</td> <td style="width: 50%; vertical-align: top;">Control PID set point A PID set point B PID set point A Staged output B Staged output A PID set point B Staged output A Staged output B PID set point A PID set point B PID set point A Staged output B Staged output A PID set point B Staged output A Staged output B PID set point B (1) PID set point A (2) PID set point B (1) Staged output A (2) Staged output B (1) Staged output A (2)</td> </tr> </table>	Enabled When 1- Occupied Unoccupied 2- Occupied Unoccupied 3- Occupied Unoccupied 4- Occupied Unoccupied 5- Blower On Blower Off 6- Blower On Blower Off 7- Blower On Blower Off 8- Blower On Blower Off 9 -DI2 (A133_P194-2) on DI1 (A133_P194-1) on Otherwise off 10-DI2 (A133_P194-2) on DI1 (A133_P194-1) on Otherwise off 11-DI2 (A133_P194-2) on DI1 (A133_P194-1) on Otherwise off (1) -DI1 (A133_P194-2) doesn't matter (2) -DI2 (A133_P194-1) is off	Control PID set point A PID set point B PID set point A Staged output B Staged output A PID set point B Staged output A Staged output B PID set point A PID set point B PID set point A Staged output B Staged output A PID set point B Staged output A Staged output B PID set point B (1) PID set point A (2) PID set point B (1) Staged output A (2) Staged output B (1) Staged output A (2)
Enabled When 1- Occupied Unoccupied 2- Occupied Unoccupied 3- Occupied Unoccupied 4- Occupied Unoccupied 5- Blower On Blower Off 6- Blower On Blower Off 7- Blower On Blower Off 8- Blower On Blower Off 9 -DI2 (A133_P194-2) on DI1 (A133_P194-1) on Otherwise off 10-DI2 (A133_P194-2) on DI1 (A133_P194-1) on Otherwise off 11-DI2 (A133_P194-2) on DI1 (A133_P194-1) on Otherwise off (1) -DI1 (A133_P194-2) doesn't matter (2) -DI2 (A133_P194-1) is off	Control PID set point A PID set point B PID set point A Staged output B Staged output A PID set point B Staged output A Staged output B PID set point A PID set point B PID set point A Staged output B Staged output A PID set point B Staged output A Staged output B PID set point B (1) PID set point A (2) PID set point B (1) Staged output A (2) Staged output B (1) Staged output A (2)							
9.02	AO1_SP_A	0 0 -0.5 0	127 5.00 0 2.5	255 10.0 0.5 5.0	Counts R:Volts M:"w.c. N:"w.c.	Analog output channel 1 set point A		
	Stg_Output_A	0	100	100	P:%	Staged output A		
9.03	AO1_SP_B	0 0 -0.5 0	127 5.00 0 2.5	255 10.0 0.5 5.0	Counts R:Volts M:"w.c. N:"w.c.	Analog output channel 1 set point B		
	Stg_Output_B	0	100	100	P:%	Staged output B.		
9.04	AO1_Startup_ Value	0 0	50 50	100 100	Counts P:%	Analog output channel 1 startup value. Value set to Analog Output during the optional startup time delay set by ECTO 9.05.		
9.05	AO1_Startup_ Delay	0 0	0 0	250 500	Counts A:Sec.	Analog output channel 1 startup delay. Optional time delay before PID loop starts.		
9.06	AO1_Min_ Out- put	0 0	20 20	100 100	Counts P:%	Analog output channel 1 minimum output.		
9.07	AO1_Max_ Output	0 0	100 100	100 100	Counts P:%	Analog output channel 1 maximum output.		

table continued on next page

Control Parameter		Control Value			Units	Description																																																				
No.	Name	Min.	Default	Max.																																																						
Block 9 Optional A133 Board in GP Mode (DIP switch set to GP) Parameters (continued)																																																										
9.08	AO1_PID_ManRS	0 0	50 50	100 100	Counts P:%	Analog output channel 1 PID loop manual reset value.																																																				
9.09	AO1_PID_P_Constant	0	0	127	Counts	Analog output channel 1 PID loop proportional constant.																																																				
9.10	AO1_PID_I_Constant	0	0	127	Counts	Analog output channel 1 PID loop integral constant.																																																				
9.11	AO1_PID_D_Constant	0	0	127	Counts	Analog output channel 1 PID loop derivative constant.																																																				
9.12	AO2_Control_Mode	0	0	11	Option	<p>Analog output channel 2 control mode. 0 - No operation. Analog Output 2 off.</p> <table border="0"> <tr> <td>Enabled When</td> <td>Control</td> </tr> <tr> <td>1- Occupied</td> <td>PID set point A</td> </tr> <tr> <td>Unoccupied</td> <td>PID set point B</td> </tr> <tr> <td>2- Occupied</td> <td>PID set point A</td> </tr> <tr> <td>Unoccupied</td> <td>Staged output B</td> </tr> <tr> <td>3- Occupied</td> <td>Staged output A</td> </tr> <tr> <td>Unoccupied</td> <td>PID set point B</td> </tr> <tr> <td>4- Occupied</td> <td>Staged output A</td> </tr> <tr> <td>Unoccupied</td> <td>Staged output B</td> </tr> <tr> <td>5- Blower On</td> <td>PID set point A</td> </tr> <tr> <td>Blower Off</td> <td>PID set point B</td> </tr> <tr> <td>6- Blower On</td> <td>PID set point A</td> </tr> <tr> <td>Blower Off</td> <td>Staged output B</td> </tr> <tr> <td>7- Blower On</td> <td>Staged output A</td> </tr> <tr> <td>Blower Off</td> <td>PID set point B</td> </tr> <tr> <td>8- Blower On</td> <td>Staged output A</td> </tr> <tr> <td>Blower Off</td> <td>Staged output B</td> </tr> <tr> <td>9- DI2 (A133_P194-2) on</td> <td>PID set point B(1)</td> </tr> <tr> <td>DI1 (A133_P194-1) on</td> <td>PID set point A(2)</td> </tr> <tr> <td>Otherwise off</td> <td></td> </tr> <tr> <td>10- DI2 (A133_P194-2) on</td> <td>PID set point B (1)</td> </tr> <tr> <td>DI1 (A133_P194-1) on</td> <td>Staged output A (2)</td> </tr> <tr> <td>Otherwise off</td> <td></td> </tr> <tr> <td>11- DI2 (A133_P194-2) on</td> <td>Staged output B(1)</td> </tr> <tr> <td>DI1 (A133_P194-1) on</td> <td>Staged output A (2)</td> </tr> <tr> <td>Otherwise off</td> <td></td> </tr> </table> <p>(1)-DI1 (A133_P194-2) doesn't matter. (2)-DI2 (A133_P194-1) is off</p>	Enabled When	Control	1- Occupied	PID set point A	Unoccupied	PID set point B	2- Occupied	PID set point A	Unoccupied	Staged output B	3- Occupied	Staged output A	Unoccupied	PID set point B	4- Occupied	Staged output A	Unoccupied	Staged output B	5- Blower On	PID set point A	Blower Off	PID set point B	6- Blower On	PID set point A	Blower Off	Staged output B	7- Blower On	Staged output A	Blower Off	PID set point B	8- Blower On	Staged output A	Blower Off	Staged output B	9- DI2 (A133_P194-2) on	PID set point B(1)	DI1 (A133_P194-1) on	PID set point A(2)	Otherwise off		10- DI2 (A133_P194-2) on	PID set point B (1)	DI1 (A133_P194-1) on	Staged output A (2)	Otherwise off		11- DI2 (A133_P194-2) on	Staged output B(1)	DI1 (A133_P194-1) on	Staged output A (2)	Otherwise off	
Enabled When	Control																																																									
1- Occupied	PID set point A																																																									
Unoccupied	PID set point B																																																									
2- Occupied	PID set point A																																																									
Unoccupied	Staged output B																																																									
3- Occupied	Staged output A																																																									
Unoccupied	PID set point B																																																									
4- Occupied	Staged output A																																																									
Unoccupied	Staged output B																																																									
5- Blower On	PID set point A																																																									
Blower Off	PID set point B																																																									
6- Blower On	PID set point A																																																									
Blower Off	Staged output B																																																									
7- Blower On	Staged output A																																																									
Blower Off	PID set point B																																																									
8- Blower On	Staged output A																																																									
Blower Off	Staged output B																																																									
9- DI2 (A133_P194-2) on	PID set point B(1)																																																									
DI1 (A133_P194-1) on	PID set point A(2)																																																									
Otherwise off																																																										
10- DI2 (A133_P194-2) on	PID set point B (1)																																																									
DI1 (A133_P194-1) on	Staged output A (2)																																																									
Otherwise off																																																										
11- DI2 (A133_P194-2) on	Staged output B(1)																																																									
DI1 (A133_P194-1) on	Staged output A (2)																																																									
Otherwise off																																																										
9.13	AO2_SP_A	0 0 -0.5 0	127 5.00 0 2.5	255 10.0 0.5 5.0	Counts R:Volts M:"w.c. N:"w.c.	Analog output channel 2 set point A																																																				
	Stg_Output_A	0	100	100	P:%	Staged output A.																																																				
9.14	AO2_SP_B	0 0 -0.5 0	127 5.00 0 2.5	255 10.0 0.5 5.0	Counts R:Volts M:"w.c. N:"w.c.	Analog output channel 2 set point B.																																																				
	Stg_Output_B	0	100	100	P:%	Staged output B.																																																				
9.15	AO2_Startup_Value	0 0	50 50	100 100	Counts P:%	Analog output channel 2 startup value. Value set to Analog Output during the optional startup time delay set by ECTO 9.16.																																																				
9.16	AO2_Startup_Delay	0 0	0 0	250 500	Counts A:Sec.	Analog output channel 2 startup delay. Optional time delay before PID loop starts.																																																				
9.17	AO2_Min_Output	0 0	20 20	100 100	Counts P:%	Analog output channel 2 minimum output.																																																				
9.18	AO2_Max_Output	0 0	100 100	100 100	Counts P:%	Analog output channel 2 maximum output.																																																				
9.19	AO2_PID_ManRS	0 0	50 50	100 100	Counts P:%	Analog output channel 2 PID loop manual reset value.																																																				
9.20	AO2_PID_P_Constant	0	0	127	Counts	Analog output channel 2 PID loop proportional constant.																																																				
9.21	AO2_PID_I_Constant	0	0	127	Counts	Analog output channel 2 PID loop integral constant.																																																				
9.22	AO2_PID_D_Constant	0	0	127	Counts	Analog output channel 2 PID loop derivative constant.																																																				

table continued on next page

Control Parameter		Control Value			Units	Description
No.	Name	Min.	Default	Max.		
Block 9 Optional A133 Board in GP Mode (DIP switch set to GP) Parameters (continued)						
9.23	DO_Control_Mode	0	0	127	Option	<p>GP1 Digital Out Control Mode = $X + 32*Y + 16*Z$ Input source = X: 0- None. 1- Compressor 1 duty cycle. (Compressor crankcase heater function.) On when OAT \leq ECTO 9.24 and \geq ECTO 9.25 seconds have passed with compressor 1 off. Off when OAT $>$ ECTO 9.24 + 3 deg F (fixed dead-band) or $<$ ECTO 9.25 seconds have passed with compressor 1 off. 2- On when occupied. 3- On when blower on, 4- On when heating demand. 5- On when cooling demand. 6- On when heating or cooling demand. 7- System RH (A55_P298_5 RH) 8- System IAQ. (A55_P298_3 IAQ) 9- System OAT (A55_P267_1/2 OAT) 10- On base on AI1. (A133_P194-6) 11- On based on AI2. (A133_P194-7) 12- On based on AI3. (A133_P194-8) 13- On based on AI4. (A133_P194-9) 14- On based on AO1. (A133_P194-11) 15- On based on AO2. (A133_P194-12)</p> <p>Algorithm Y for input sources 7-15: 0- Hysteresis loop On when input \geq ECTO 9.24 Off when input $<$ ECTO 9.24-ECTO 9.25 Window 1- On when input is in range; \geq ECTO 9.24 and \leq ECTO 9.24 + ECTO 9.25 (Fixed 3-count hysteresis loop on rising and falling edges of window.) 2- Delayed-on. On when input is \geq ECTO 9.24 for \geq ECTO 9.25 seconds. Off when input is $<$ ECTO 9.24 - 3. (Fixed 3-count hysteresis loop on edge.) 3- Delayed-off. On when input is \geq ECTO 9.24. Off when input is $<$ ECTO 9.24 - 3 for \geq ECTO 9.25 seconds. (Fixed 3-count hysteresis loop on edge.)</p> <p>Inversion Z: 0 - Output not inverted. 1 - Output inverted.</p>
						<p>Graphs indicate output not inverted. see figure 33.</p>
9.24	DO_SP	0 0 16 0 132 -0.5 0	127 5.0 996 100 51 0 2.5	255 10.0 2000 100 -31 0.5 5.0	Counts R:Volts I:ppm P: % Y:DegF M:"w.c. N:"w.c.	Digital output control mode set point
9.25	DO_DB	2 0 0 2 1 64 0.01 0	13 .50 102 13 8 416 .05 .25	255 10.0 2000 100 162 8160 1.0 5.0	Counts R:Volts I:ppm P: % O:DegF D:Sec. L:"w.c. N:"w.c.	Digital output control mode dead-band or delay.

Table 42. ECTO Parameter Code Conversion Table

Codes A Through F

Counts	A		B		C		D	E	F
	Sec.	Min.	Sec.	Min.	Sec.	Min.	Min.	Hrs.	Min.
0	0	0	0	0	0	0	0	0	0
10	20	0.33	40	0.67	80	1.33	5.33	0.36	2.67
20	40	0.67	80	1.33	160	2.67	10.67	0.71	5.33
30	60	1.00	120	2.00	240	4.00	16.00	1.07	8.00
40	80	1.33	160	2.67	320	5.33	21.33	1.42	10.67
50	100	1.67	200	3.33	400	6.67	26.67	1.78	13.33
60	120	2.00	240	4.00	480	8.00	32.00	2.13	16.00
70	140	2.33	280	4.67	560	9.33	37.33	2.49	18.67
80	160	2.67	320	5.33	640	10.67	42.67	2.84	21.33
90	180	3.00	360	6.00	720	12.00	48.00	3.20	24.00
100	200	3.33	400	6.67	800	13.33	53.33	3.56	26.67
110	220	3.67	440	7.33	880	14.67	58.67	3.91	29.33
120	240	4.00	480	8.00	960	16.00	64.00	4.27	32.00
130	260	4.33	520	8.67	1040	17.33	69.33	4.62	34.67
140	280	4.67	560	9.33	1120	18.67	74.67	4.98	37.33
150	300	5.00	600	10.00	1200	20.00	80.00	5.33	40.00

Codes I Through O

Counts	I	J	L	M	N	O
	CO ₂ ppm	mA	Pres. "w.c.	Pres. "w.c.	Pres. "w.c.	Differential Temp. F (C)
0	0	0	0	-0.5	0	0 (0.00)
10	78.43	0.78	0.04	-0.46	0.20	6.36 (3.53)
20	156.86	1.57	0.08	-0.42	0.39	12.72 (7.07)
30	235.29	2.35	0.12	-0.38	0.59	19.08 (10.60)
40	313.72	3.14	0.16	-0.34	0.78	25.44 (14.13)
50	392.15	3.92	0.20	-0.30	0.98	31.80 (17.67)
60	470.58	4.71	0.24	-0.26	1.18	38.16 (21.20)
70	549.01	5.49	0.27	-0.23	1.37	44.52 (24.73)
80	627.44	6.27	0.31	-0.19	1.57	50.88 (28.27)
90	705.87	7.06	0.35	-0.15	1.76	57.24 (31.80)
100	784.3	7.84	0.39	-0.11	1.96	63.60 (35.33)
110	862.73	8.63	0.43	-0.07	2.16	69.96 (38.87)
120	941.16	9.41	0.47	-0.03	2.35	76.32 (42.40)
130	1019.6	10.20	0.51	0.01	2.55	82.68 (45.93)
140	1098	10.98	0.55	0.05	2.75	89.04 (49.47)
150	1176.5	11.76	0.59	0.09	2.94	95.40 (53.00)
160	1254.9	12.55	0.63	0.13	3.14	101.76 (56.53)
170	1333.3	13.33	0.67	0.17	3.33	108.12 (60.07)
180	1411.7	14.12	0.71	0.21	3.53	114.48 (63.60)
190	1490.2	14.90	0.75	0.25	3.73	120.84 (67.13)
200	1568.6	15.69	0.78	0.28	3.92	127.20 (70.67)
210	1647	16.47	0.82	0.32	4.12	133.56 (74.20)
220	1725.5	17.25	0.86	0.36	4.31	139.92 (77.73)
230	1803.9	18.04	0.90	0.40	4.51	146.28 (81.27)
240	1882.3	18.82	0.94	0.44	4.71	152.64 (84.80)
250	1960.8	19.61	0.98	0.48	4.90	159.00 (88.33)
255	2000	20.00	1.00	0.50	5.00	162.18 (90.10)

Table 42. ECTO Parameter Code Conversion Table (continued)

Codes P Through Z

Counts	P	R	V		W		X		Y		Z	
	%	VDC	Diff. Temp.		Diff. Temp.		Temp.		Temp.		Temp.	
			F	C	F	C	F	C	F	C	F	C
0	0	0	0	0	0	0	164.45	73.58	131.56	55.31	100	37.78
10	10	0.39	6.79	3.77	2.50	1.39	157.66	69.81	125.20	51.78	97.50	36.39
20	20	0.78	13.58	7.55	5.00	2.78	150.87	66.04	118.84	48.24	95.00	35.00
30	30	1.18	20.38	11.32	7.50	4.17	144.07	62.26	112.48	44.71	92.50	33.61
40	40	1.57	27.17	15.09	10.00	5.56	137.28	58.49	106.12	41.18	90.00	32.22
50	50	1.96	33.96	18.87	12.50	6.94	130.49	54.72	99.76	37.64	87.50	30.83
60	60	2.35	40.75	22.64	15.00	8.33	123.70	50.94	93.40	34.11	85.00	29.44
70	70	2.75	47.54	26.41	17.50	9.72	116.91	47.17	87.04	30.58	82.50	28.06
80	80	3.14	54.34	30.19	20.00	11.11	110.11	43.40	80.68	27.04	80.00	26.67
90	90	3.53	61.13	33.96	22.50	12.50	103.32	39.62	74.32	23.51	77.50	25.28
100	100	3.92	67.92	37.73	25.00	13.89	96.53	35.85	67.96	19.98	75.00	23.89
110	100	4.31	74.71	41.51	27.50	15.28	89.74	32.08	61.60	16.44	72.50	22.50
120	100	4.71	81.50	45.28	30.00	16.67	82.95	28.30	55.24	12.91	70.00	21.11
130	100	5.10	88.30	49.05	32.50	18.06	76.15	24.53	48.88	9.38	67.50	19.72
140	100	5.49	95.09	52.83	35.00	19.44	69.36	20.76	42.52	5.84	65.00	18.33
150	100	5.88	101.88	56.60	37.50	20.83	62.57	16.98	36.16	2.31	62.50	16.94
160	100	6.27	108.67	60.37	40.00	22.22	55.78	13.21	29.80	-1.22	60.00	15.56
170	100	6.67	115.46	64.15	42.50	23.61	48.99	9.44	23.44	-4.76	57.50	14.17
180	100	7.06	122.26	67.92	45.00	25.00	42.19	5.66	17.08	-8.29	55.00	12.78
190	100	7.45	129.05	71.69	47.50	26.39	35.40	1.89	10.72	-11.82	52.50	11.39
200	100	7.84	135.84	75.47	50.00	27.78	28.61	-1.88	4.36	-15.36	50.00	10.00
210	100	8.24	142.63	79.24	52.50	29.17	21.82	-5.66	-2.00	-18.89	47.50	8.61
220	100	8.63	149.42	83.01	55.00	30.56	15.03	-9.43	-8.36	-22.42	45.00	7.22
230	100	9.02	156.22	86.79	57.50	31.94	8.23	-13.20	-14.72	-25.96	42.50	5.83
240	100	9.41	163.01	90.56	60.00	33.33	1.44	-16.98	-21.08	-29.49	40.00	4.44
250	100	9.80	169.80	94.33	62.50	34.72	-5.35	-20.75	-27.44	-33.02	37.50	3.06
255	100	10.00	173.20	96.22	63.75	35.42	-8.75	-22.64	-30.62	-34.79	36.25	2.36

Table 43. Code Conversion

Code	Type	Value	Convert Counts to Value	Convert Value to Counts
A	Timer	Seconds	2 x Counts	Seconds / 2
B	Timer	Seconds	4 x Counts	Seconds / 4
C	Timer	Seconds	8 x Counts	Seconds / 8
D	Timer	Seconds	32 x Counts	Seconds / 32
E	Timer	Seconds	128 x Counts	Seconds / 128
F	Timer	Seconds	16 x Counts	Seconds / 16
I	IAQ	ppm CO ₂	7.843 x Count	ppm / 7.843
J	0-20mA	mA	Counts / 12.75	mA x 12.75
L	"w.c. Differential For M	"w.c.	Counts / 255	"w.c. x 255
M	"w.c. -0.5 - +0.5	"w.c.	(Count/255) - 0.5	("w.c. + 0.5) x 255
N	"w.c. Differential For N	"w.c.	Count / 51	"w.c. x 51
N	N (0.0 - 5.0)	"w.c.	Count / 51	"w.c. x 51
O	OAT Differential	Degrees °F	0.6360 x Count	Deg F / 0.6360
P	Percent	Percent	Counts (maximum = 100)	Percent
R	0-10V	Volt	Count / 25.5	Volt x 25.5
V	RAT, DAT Differential	Degrees °F	0.6792 x Counts	Deg F / 0.6792
W	ZAT Differential	Degrees °F	Counts / 4	Deg F x 4
X	RAT, DAT	Degrees °F	164.45 - (.6792 x Counts)	(164.45 - Deg F) / 0.6792
Y	OAT	Degrees °F	131.56 - (.6360 x Counts)	(131.56 - Deg F) / 0.6360
Z	ZAT	Degrees °F	100 - (Counts / 4)	(100 - Deg F) x 4

18. Networking The Controllers

A network control panel (NCP) and NCP PC software can be used to schedule building operation for any M2 on the same daisy-chained L connection network.

The network thermostat controller (NTC) is an L connection direct digital controller used on units which are not equipped with an M2. The Building Controller (BC) is used to control building functions such as lights and signs. Use L connection specific network cable and daisy chain as shown in figure 35.

Up to 31 controllers can be daisy chained on a single L connection network. Any combination of M2, M1, NTC, and BC controller can be used (see figure 34).

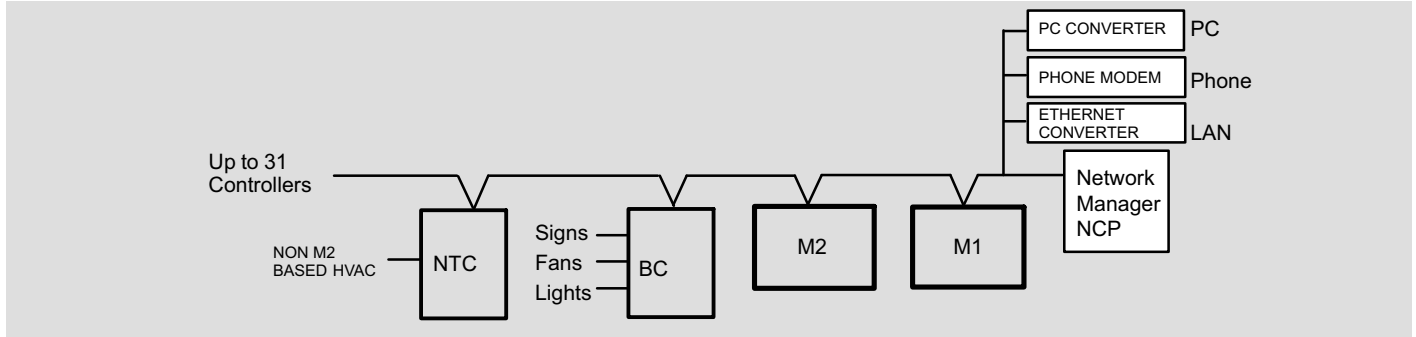

Figure 34. L Connection Network

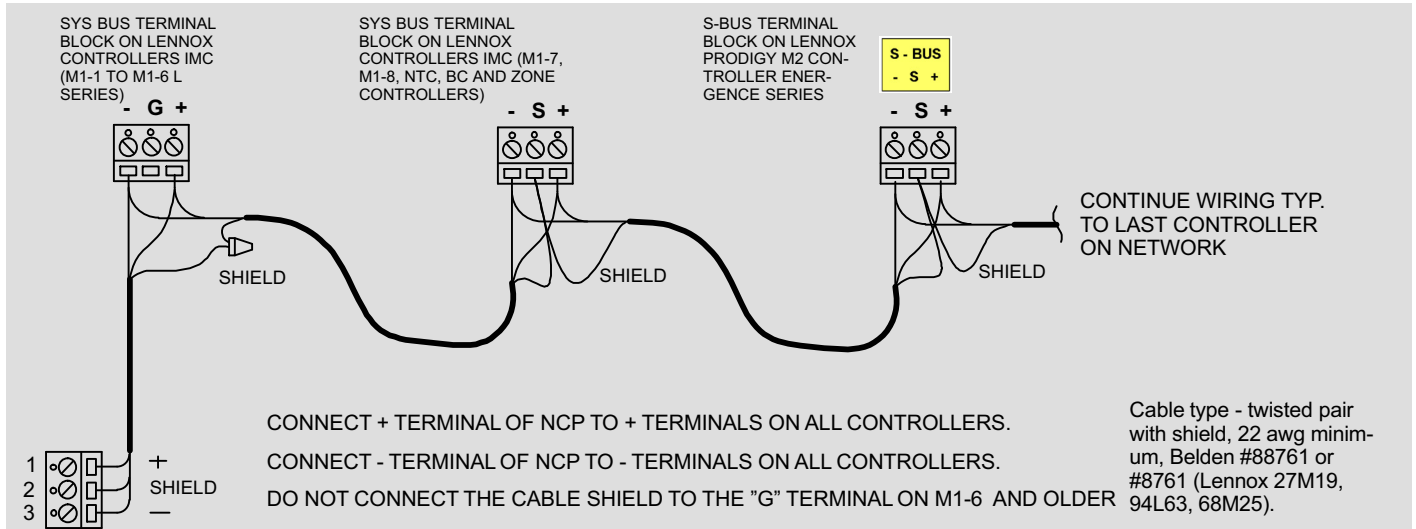

Figure 35. L Connection® Network Daisy-chain Communication Wiring

19. Sequence of Operation

19.1. Unit Controller Control Modes

Unit Controller can operate in several different control modes. The selection of these control modes will depend upon several factors:

- Unit type - constant air volume (CAV) or variable air volume (VAV) with supply fan variable frequency drive.
- Zoning application (single zone, bypass zoning or zoning)
- Which device will control rooftop unit staging and unit operation (thermostat / third party unit controller or the Unit Controller)
- The desired level of unit heating and cooling staging (2 heat / 2 cool or 4 heat / 4 cool)

19.1.1. Unit Controller In Zone Sensor Mode

When in the zone sensor mode, the unit controller can provide up to four stages of mechanical heating and cooling operation. Constant volume units in single zone applications can use this control mode. The zone sensor will provide space temperature information to the unit controller. The unit controller houses all space temperature set points and controls all rooftop unit staging and general operation. The unit controller also determines unit error codes, provides diagnostic information and maintains safe operation limits. It is important to note that scheduling and/or set point control requires the use of a L Connection Network Control Panel.

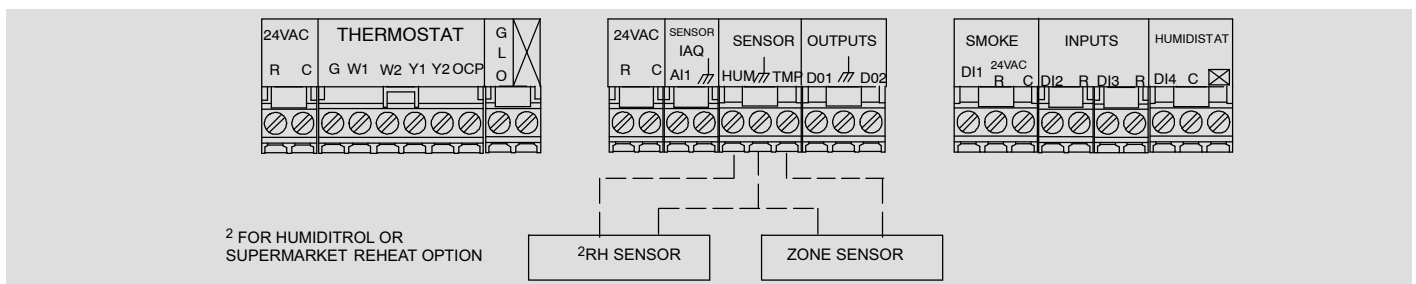

Figure 36. Constant Air Volume Unit in Single Zone Application

19.1.2. Unit Controller In Thermostat Mode

When in the thermostat mode, the unit controller can provide up to two stages of mechanical heating and cooling operation. Constant volume units in either single zone or bypass zoning applications can use this control mode. To operate correctly, a Lennox or third-party thermostat or unit control must provide the following wiring connections to the unit controller:

1. Ventilation demand
2. Occupied demand
3. Heating demand one
4. Heating demand two
5. Cooling demand one
6. Cooling demand two

In this configuration, either the thermostat or unit control will control the rooftop unit staging and general operation. The unit controller functions primarily to determine unit error codes, provide diagnostic information and maintain safe operation limits.

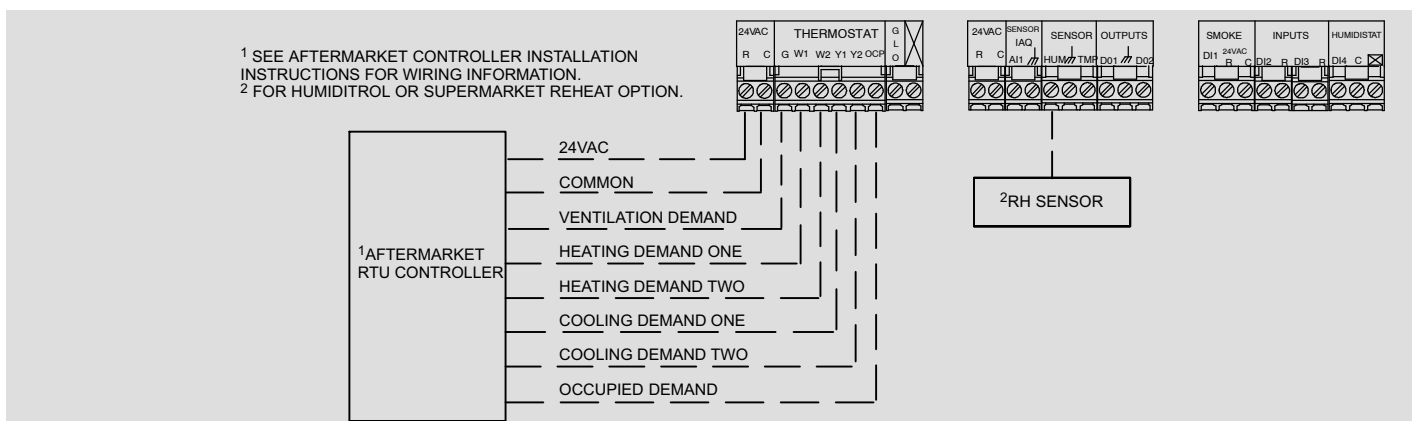

Figure 37. Constant Air Volume Unit In Single Zone Application

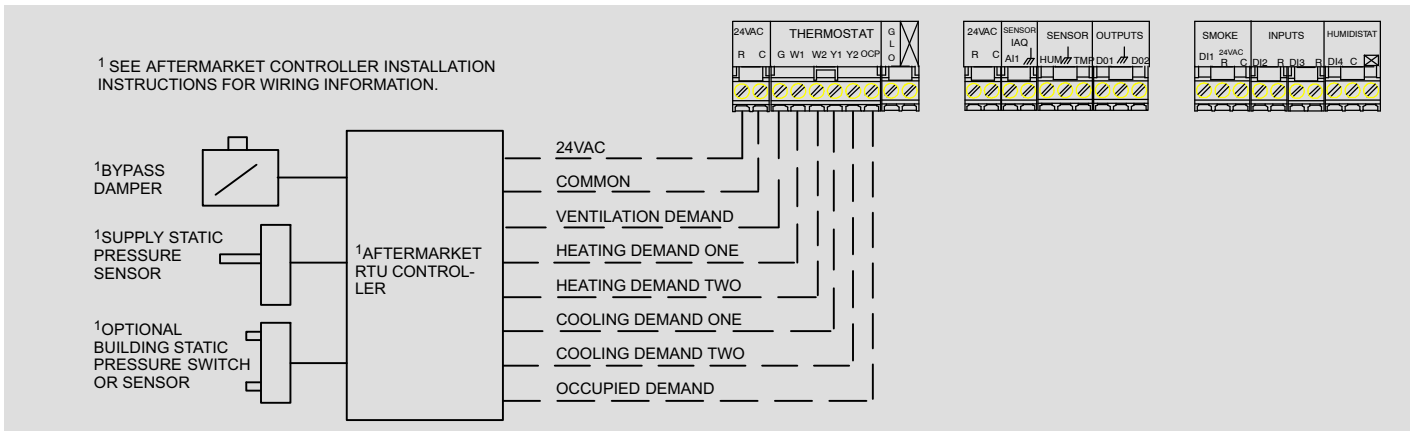

Figure 38. Constant Air Volume Unit in Bypass Zoning Application

When in thermostat mode and configured for discharge air temperature control, the unit controller can provide up to four stages of mechanical heating and cooling operation. Variable air volume units using a variable frequency drive on the supply fan and operating in a zoning application must use this control mode. Although not as common, constant volume units in either single zone or bypass zoning applications may also use this control mode. To operate correctly, a Lennox or third-party thermostat or unit control must provide the following wiring connections to the unit controller:

1. Ventilation demand
2. Occupied demand
3. Heating demand
4. Cooling demand

In this control mode the unit controller will control all cooling and heating staging to maintain the the discharge air temperature set points set in the unit controller (typically 55°F for cooling and 110°F for heating). A third-party unit control, or a thermostat can provide these inputs to the unit controller. For example, if the unit control passes along a demand for cooling then the unit controller will activate the refrigeration system and increase or decrease cooling stages to maintain the discharge supply air temperature set point. In this mode, the unit controller will also maintain the supply duct static pressure by directly controlling the supply fan variable frequency drive. Along with providing control of the rooftop unit, the unit controller will also provide error codes and diagnostic information.

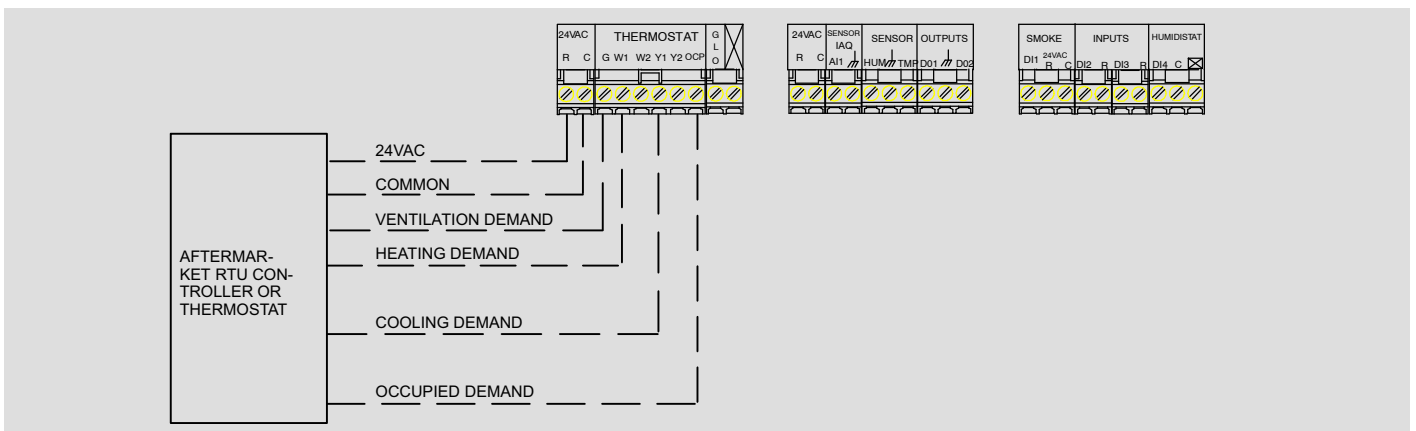

Figure 39. Variable Air Volume Unit in Zoning Application

19.1.3. Operations Common to All Rooftop Units

The following sequence of operation information applies to all Emergence rooftop units regardless of unit controller control mode, unit type or zoning application.

19.1.3.1. Heating Operation (Modulating Gas)

The Emergence unit features two separate gas burner sections, each with a modulating gas valve and a shut-off valve. The modulating gas heat section can provide continuous operation from 25-100% of total heat capacity. Upon receiving a heating demand, the unit controller will instruct the modulating gas unit to maintain a discharge air temperature set point (default 110°F). The unit maintains this set point by feeding information from a discharge air temperature sensor located in the supply duct back to the unit controller. Based on this information, the unit controller increases or decreases gas heat output to maintain the desired heating set point.

The unit controller controls modulation by adjusting either one or both of the gas burner sections. Upon receiving a heating demand, the unit controller will bring on both gas burner sections at 100%. When the discharge air temperature reaches the set point (default 110°F), the unit controller will modulate both gas burner sections by the same amount between 100% and 50% to maintain the set point. If less heat is required to maintain the set point, the unit controller will turn off the second gas burner section and modulate the first gas burner section between 100% and 50% (50% to 25% of total unit capacity).

The basic operation of modulating gas remains the same regardless of unit type or unit controller mode. Gas heat modulation requires the necessary mechanical components, a discharge air temperature sensor located in the supply duct and a single heating demand to the unit controller.

19.1.3.2. Occupied Demand

Upon receiving occupied and ventilation demands from the Lennox or third party unit controller, the unit controller adjusts the fresh air damper to either a fixed minimum position or allows it to modulate based on a CO₂ sensor (demand control ventilation). The CO₂ sensor can be wired directly to the unit controller, to another controller that can monitor the sensor and pass a signal to the unit controller for damper control, or to both the unit controller and another device for monitoring through the desired man-machine interface while the unit controller maintains damper control.

During morning warm-up the unit controller keeps the fresh air damper closed based on unit controller configuration settings. Set points for minimum and maximum damper position and CO₂ control reside in the unit controller memory, have factory default settings, and may be adjusted at start up. The user can change these settings either locally or remotely through Lennox' L Connection Network® Unit Controller Software. The user will not have the ability to adjust the settings through third party software or control devices.

19.1.3.3. Demand Control Ventilation

Demand control ventilation is used in applications where the demand for fresh outdoor air fluctuates during the occupied time period. Using a CO₂ sensor connected directly to the unit controller, the unit can intelligently increase or decrease the amount of fresh outdoor air by changing the outdoor air damper position. The unit controller has two operation modes available, set point or proportional, to control the outdoor air damper position.

19.1.3.4. Fresh Air Tempering (FAT)

In applications with large outdoor air requirements, Fresh Air Tempering is used to minimize temperature fluctuations in the conditioned space. The unit controller controls discharge air temperature by energizing heating or cooling in response to the discharge supply air duct temperature. Fresh air tempering only occurs when there is no heating or cooling demand from the occupied space. The user must configure the unit controller to turn on the fresh air tempering option.

Heating is energized when discharge air temperature falls below fresh air heating set point (60°F default) and terminates when the return air temperature is less than the set point. Cooling is energized when discharge air temperature rises above fresh air cooling set point (80°F default) and terminates when the return air temperature is greater than the set point. FAT will operate up to four stages of heating and cooling to maintain discharge air temperature. Standard heating and cooling demands will override FAT heating and cooling demands.

19.1.3.5. Hot Gas Bypass

By selecting the hot gas bypass option, the unit can operate in low airflow applications down to 12.5% of nominal capacity. As the suction line pressure decreases and the potential for coil frosting increases, the mechanical system bypasses hot refrigerant gas from the first stage compressor discharge line back to the suction line. The hot gas increases the pressure of the suction line and reduces the compressor capacity. A de-superheater valve bypasses refrigerant from the liquid line and mixes it with the hot gas before entering the suction line to maintain the set point suction gas superheat entering the compressor.

19.1.3.6. Discharge Air Cooling Reset Operation

Discharge air cooling reset operation saves energy by gradually increasing the discharge air set point as outside air temperature decreases. This operation also reduces the potential for over-cooling if the zoning system is misapplied, has an abnormal condition, or has a dominant zone. The unit controller has various advanced discharge air cooling reset options which can be selected at start up and are based on either return air temperature, outside air temperature, or both return and outdoor air temperature.

19.1.3.7. Discharge Air Heating Reset Operation

Discharge air heating reset operation saves energy by gradually decreasing the discharge air set point as outside air temperature increases. This operation reduces the potential for overheating if the zoning system is misapplied, has an abnormal condition, or has a dominant zone. The unit controller has various advanced discharge air heating reset options which can be selected at start up and are based on either return air temperature, outside air temperature or both return and outdoor air temperature.

19.1.3.8. Building Pressure Control for Standard or High Static Power Exhaust Fans

Energence units can control building static pressure with either a standard or high static power exhaust fan. Each fan type is available in either a 50% (one fan) or 100% (two fans) configuration. Standard static power exhaust fans use a propeller while high static power exhaust fans use a centrifugal blower. All units featuring power exhaust fans must also have an economizer for proper operation.

Control of the fans can occur based on damper position or building differential static pressure transducers located outside the building and in the return duct. Using the differential pressure transducer allows for more precise control of building static pressure and ultimately better performance. Control of power exhaust fans can occur through the unit controller, third party device or separate unit controller.

19.1.3.9. Damper Position Control

Power exhaust fans (standard or high static) with damper position control use damper position to determine when to activate fan operation. When the economizer damper is closed, the power exhaust fan will remain off. Once the economizer modulates open past a pre-determined position, the power exhaust fan will turn on. This allows the unit to relieve a portion of the incoming fresh outdoor air and help reduce building static pressure.

If using a 100% (two fans) power exhaust configuration, a second power exhaust fan will turn on once the economizer damper modulates open past a second pre-determined position. Turning on the second fan will allow the unit to further reduce building static pressure.

19.1.3.10. Differential Static Pressure Control

Power exhaust fans (standard or high static) with building differential static pressure transducer control use the actual building static pressure relative to the outdoor atmospheric pressure to activate fan operation. Based on actual building static pressure as determined by the building differential pressure transducer, the unit controller, third party device or unit controller will instruct the power exhaust fan(s) to turn on or off as needed to maintain the building static pressure set point. Turning on the fans decreases building pressure, while stopping fan operation increases building pressure. Power exhaust configurations with two fans have two stage capability for improved building static pressure performance and enhanced control. The building pressure set point resides in the unit controller.

19.1.3.11. Building Pressure Control for High Static Power Exhaust Fans with Variable Frequency Drives

Energence units can control building static pressure with a high static power exhaust fan featuring a variable frequency drive, using building differential static pressure control. This system provides precise and powerful control of building static pressure. This system uses actual building static pressure relative to the outdoor atmospheric pressure and a variable frequency drive to activate fan operation and modulate fan speed. It is important to note that the unit controller connects directly to and controls the variable frequency drive and that the building static pressure set point resides in the unit controller.

Based on the actual building static pressure (as determined by the building pressure transducer) the unit controller instructs the power exhaust fan(s) to increase or decrease speed as needed to maintain the building static pressure set point. Increasing fan speed decreases building pressure while decreasing fan speed increases building pressure. Power exhaust configurations with two fans (100% capacity) have the ability to remove more exhaust air than single fan configurations.

19.1.4. Constant Air Volume (CAV) Units in Single Zone Applications with a Lennox Zone Sensor (4 Heat / 4 Cool)

19.1.4.1. Unit Controller Operation

When using a Lennox zone sensor with the unit controller operating in zone sensor mode, a packaged rooftop unit can provide up to four stages each of mechanical heating and cooling operation. The zone sensor provides space temperature information to the unit controller. The unit controller houses all space temperature set points and controls all rooftop unit staging and general operation functions. The unit controller also determines unit error codes, provides diagnostic information and maintains safe operation limits.

19.1.4.2. Ventilation Demand

When the unit controller is in zone sensor control mode, the user has several different ventilation sequence of operation scenarios to choose from. The default mode causes the unit controller to activate the supply fan when both a ventilation and either heating or cooling demand are present. This occurs independent of receiving an occupied demand. The user can change the default setting to allow the supply fan to run continuously when the unit controller receives both a ventilation and occupied demand. This is independent of a call for either heating or cooling. When the unit controller receives a ventilation demand and occupied demand is not present, the unit controller will only activate the supply fan when it receives either a heating or cooling demand.

19.1.4.3. Cooling Demand

The unit controller directly monitors space temperature through the zone sensor. Based on this information, the unit controller activates the different compressor stages to maintain the desired occupied space temperature set point. Increasing compressor stages provides more cooling capacity while decreasing compressor stages provides less cooling capacity. The unit controller has direct control over the rooftop unit mechanical cooling staging operation. The user has the option to configure the unit controller so that if the zone sensor fails, the unit controller can use a backup operation to control unit operation.

Energence units feature four separate compressors and refrigeration circuits that can provide up to four stages of mechanical cooling operation.

For stage one operation, the unit controller activates the first compressor (25% of total unit capacity). For stage two operation, the unit controller activates the second compressor (50% unit capacity). For stage three operation, the unit controller activates the third compressor (75% total unit capacity). For stage four operation, the unit controller activates the fourth compressor (100% unit capacity). Depending on the zone sensor configuration setting, occupants in the space can change the set point. The unit controller automatically recognizes this change and instructs the unit to respond accordingly.

19.1.4.4. Cooling Demand with Economizer

If the outdoor air is suitable for free cooling and the unit has an economizer, the unit controller will open the economizer and use fresh air for stage one cooling. For stage two cooling operation, the unit controller activates the first compressor. For stage three cooling operation, the unit controller activates the second compressor. For stage four cooling operation, the unit controller activates the remaining compressors (number three and four). The unit controller has direct control over the rooftop unit mechanical cooling staging and economizer operation.

19.1.4.5. Heating Demand (General Operation)

The unit controller directly monitors space temperature through the zone sensor. Based on this information, the unit controller turns on or off the heating stages to maintain the desired temperature set point. Increasing heating stages provides additional heating capacity while decreasing heating stages provides less heating capacity. The unit controller has direct control over rooftop unit mechanical heating staging operation. Emergence units feature four separate heating stages that can provide up to four stages of mechanical heating operation. The specific heating capacity varies for each stage depending on the heat source. Depending on the zone sensor configuration setting, occupants in the space can change the set point. The unit controller automatically recognizes this change and instructs the unit to respond accordingly.

19.1.4.6. Heating Demand (Electric)

Emergence units feature multiple electric heat sections available in sizes from 30 kW to 180 kW (depending on unit size and voltage). Units can provide up to four stages of mechanical heating depending on the size of the electric heater. Staged operation occurs similar to cooling operation, with the unit controller activating or deactivating sections of the electric heater as the demand for heat increases or decreases.

19.1.4.7. Humiditrol Dehumidification Operation - Dehumidification Demand

Upon a dehumidification only demand, the unit controller activates compressors number one and two. At the same time, the unit controller uses solenoid valves to divert hot gas from compressors one and two to the first reheat coil. The cooled and dehumidified air from the evaporator is then reheated as it passes through the reheat coil. The de-superheated and partially condensed refrigerant continues to the outdoor condenser coil where condensing is completed.

The reheat coil is sized to offset most of the first and second stages of sensible cooling effect during reheat only operation. This reduction in sensible cooling capacity extends compressor run time to control humidity when cooling loads are light. The unit continues to operate in this mode until the dehumidification demand is satisfied. A heating demand terminates reheat operation.

The unit controller relative humidity set point is set at the factory for 60% and can be adjusted at the unit controller or with the L Connection Network Unit Controller Software. For Network Control Panel (NCP) applications, the humidity set point can be adjusted at the NCP. The unit controller also has an option for an external digital input for the dehumidification demand. This demand must be provided from an external third party unit controller.

19.1.4.8. Humiditrol Dehumidification Operation - Cooling Demand Only

The unit will operate conventionally whenever there is a demand for cooling and no dehumidification demand. The unit can provide up to four stages of mechanical cooling in this scenario. Free cooling is only permitted when an economizer is present, there is no demand for dehumidification and the outdoor air is suitable for this function.

19.1.4.9. Humiditrol Dehumidification Operation - Cooling and Dehumidification Demand

Stage one cooling demand with dehumidification demand: If both a dehumidification demand and a first stage cooling demand occur, the system activates the first three compressors plus reheat. This provides approximately 75% humidity removal capacity plus 25% cooling capacity.

Stage two cooling demand with dehumidification demand: A demand for second stage cooling plus dehumidification activates all four compressors plus reheat. This provides 100% humidity removal capacity plus approximately 50% cooling capacity.

Stage three cooling demand with dehumidification demand: A demand for stage three cooling plus dehumidification activates all three compressors. The fourth compressor and reheat coil will cease operation. This provides approximately 75% of humidity removal capacity and 75% cooling capacity.

Stage four cooling demand with dehumidification demand: A demand for stage four cooling plus dehumidification activates all four compressors. This will provide 100% humidity removal capacity and 100% cooling capacity.

19.1.5. Constant Air Volume (CAV) Units in Single Zone Applications with a Thermostat or Third Party Unit Controller (2 Heat / 2 Cool)

19.1.5.1. Unit Controller Operation

When using a two-stage heat/ cool thermostat or third party unit controller with the unit controller in the thermostat mode, a packaged rooftop unit can provide up to two stages of mechanical heating and cooling operation. To operate correctly, a thermostat or third party unit controller must provide the following wiring connections to the unit controller:

1. Ventilation demand
2. Occupied demand
3. Heating demand one
4. Heating demand two
5. Cooling demand one
6. Cooling demand two

In this set up, either the thermostat or third party unit controller controls the rooftop unit staging and general operation. The unit controller functions primarily to determine unit error codes, provide diagnostic information and maintain safe operation limits.

19.1.5.2. Ventilation Demand

Upon receiving a ventilation demand from the thermostat or third party unit controller, the unit controller instructs the supply fan to start operation. The supply fan runs at full capacity as long as a ventilation demand is present.

19.1.5.3. Cooling Demand

Upon receiving a stage one demand for cooling from the thermostat or third party unit controller, the unit controller activates the first two compressors, providing 50% cooling capacity.

If the unit is unable to satisfy the call for cooling within a specified time period and receives a stage two cooling demand from the thermostat or third party unit controller, the unit controller activates the third and fourth compressors, providing 100% cooling capacity. The thermostat or third party unit controller has direct control over the rooftop unit's staging capability.

19.1.5.4. Cooling Demand With Economizer

If the unit features an economizer and outdoor air is suitable for free cooling, a call for stage one cooling will activate the economizer. The unit will try to satisfy the cooling demand using outdoor air rather than mechanical cooling.

If the unit is unable to satisfy the call for cooling within a specified time period using the economizer and receives a stage two call for cooling from the thermostat or third party unit controller, the unit controller activates all four compressors. This will provide 100% cooling capacity. It is important to note that the thermostat or third party unit controller has direct control over the rooftop unit's staging capability. While the unit controller typically has direct control over the economizer, it is possible for a thermostat or third party unit controller to directly control this functionality.

19.1.5.5. Heating Demand (General Operation)

Upon receiving a stage one heating demand from the thermostat or third party unit controller, the unit controller activates the unit's heating section to start operation. This activates the first two stages of mechanical heat, providing approximately 66% heating capacity.

If the unit is unable to satisfy the call for heating within a specified time period and receives a stage two heating demand from the thermostat or third party controller, the unit controller activates the third and fourth stages of heat, providing 100% heating capacity. It is important to note that the thermostat or third party unit controller has direct control over the rooftop unit's staging capability.

19.1.5.6. Heating Demand (Electric)

Units feature multiple electric heat sections available in sizes from 30 kW to 180 kW (depending on unit size and voltage). Units can provide up to two stages of mechanical heating depending on the size of the electric heater. Staged operation occurs similar to cooling operation, with the thermostat or third party unit controller activating or deactivating sections of the electric heater as the demand for heat increases or decreases.

19.1.5.7. Humiditrol Dehumidification Operation - Dehumidification Demand

Upon a dehumidification demand, the unit controller activates compressor number one and two. At the same time, the unit controller uses solenoid valves to divert hot gas from compressor one and two to the first reheat coil. The cooled and dehumidified air from the evaporator is then reheated as it passes through the reheat coil. The de-superheated and partially condensed refrigerant continues to the outdoor condenser coil where condensing is completed. The reheat coil is sized to offset most of the first and second stages of sensible cooling effect during reheat only operation. This reduction in sensible cooling capacity extends compressor run time to control humidity when cooling loads are light.

The unit will continue to operate in this mode until the dehumidification demand is satisfied. A heating demand will terminate reheat operation.

The unit controller relative humidity set point is factory configured for 60% and can be adjusted at the unit controller or with the L Connection Network Unit Controller software. For Network Control Panel (NCP) applications, the humidity set point can be adjusted at the NCP. The unit controller also has an option for an external digital input to signal the dehumidification demand. This demand must be provided from an external third party DDC.

19.1.5.8. Humiditrol Dehumidification Operation - Cooling Demand Only

The unit operates conventionally whenever there is a demand for cooling and no dehumidification demand. The unit can provide up to two stages of mechanical cooling in this scenario. Free cooling is only permitted when an economizer is present, there is no demand for dehumidification and outdoor air is suitable for this function.

19.1.5.9. Humiditrol Dehumidification Operation - Cooling and Dehumidification Demand

Stage one cooling demand with dehumidification demand: If both a dehumidification demand and a first stage cooling demand occur, the system activates all four compressors plus the first stage of reheat. This provides 100% humidity removal capacity with approximately 50% cooling capacity.

Stage two cooling demand with dehumidification demand: A demand for second stage cooling activates all four compressors plus terminates any reheat operation. This provides 100% humidity removal capability and 100% cooling capacity. The unit controller activates all compressors until the cooling demand is satisfied

19.1.6. Constant Air Volume (CAV) Units in Single Zone Applications with a Thermostat or Third Party Unit Controller and the Unit Operating in Discharge Air Temperature Control (4 Heat / 4 Cool)

19.1.6.1. Unit Controller Operation

When using a thermostat or third party unit controller with the unit controller operating in the thermostat mode configured for discharge air temperature control, a packaged rooftop unit can provide up to four stages of mechanical heating and cooling operation.

To operate correctly, a thermostat or third party controller must provide the following wiring connections to the unit controller:

1. Ventilation demand
2. Occupied demand
3. Heating demand
4. Cooling demand

In this configuration the unit controller will control the rooftop staging and general operation. The thermostat or third party unit controller only informs the unit controller if there is a specific demand. For example, if the thermostat or third party unit controller passes along a demand for cooling, the controller increases or decreases cooling stages to maintain the discharge supply air temperature set point. Along with providing control of the rooftop unit, the unit controller also provides error codes, diagnostic information and maintains safe operating limits.

19.1.6.2. Ventilation Demand

Upon receiving a ventilation demand from the thermostat or unit controller, the unit controller activates the supply fan. The supply fan operates at 100% capacity until the ventilation demand has been removed.

19.1.6.3. Cooling Demand

Upon receiving a cooling demand from the thermostat or unit controller, the unit controller instructs the unit to maintain a cooling discharge air temperature set point. The unit controller has direct control over the rooftop unit staging. The discharge supply air temperature set point resides in the unit controller, has a factory default setting, and can be adjusted at start-up. The user can adjust the set point either locally or remotely with Lennox' L Connection Network Unit Controller software or at the unit controller board. The user can not adjust the set point through a third party control device or software program.

The unit controller receives discharge supply air temperature information directly from the temperature sensor, located in the supply duct system. Based on this information, the unit controller activates the different compressor stages to maintain the discharge supply air temperature set point (55°F default). Increasing compressor stages provides more cooling capacity while decreasing compressor stages provides less cooling capacity.

Emergency units feature four separate compressors and refrigeration circuits that can provide up to four stages of mechanical cooling operation.

- For stage one operation, the unit controller activates the first compressor (25% of total unit capacity).
- For stage two operation, the unit controller activates the second compressor (50% unit capacity).
- For stage three operation, the unit controller activates the third compressor (75% total unit capacity).
- For stage four operation, the unit controller activates the fourth compressor (100% unit capacity).

19.1.6.4. Cooling Demand With Economizer

If outdoor air is suitable for free cooling and the unit has an economizer, the unit controller opens the economizer and uses fresh air for stage one cooling.

- For stage two operation, the unit controller activates one compressor.

- For stage three operation, the unit controller activates a second compressor.
- For stage four operation, the unit controller activates the remaining compressors (number three and four).

The unit controller has direct control over the rooftop unit staging and economizer operation.

19.1.6.5. Heating Demand (General Operation)

Upon receiving a heating demand from a thermostat or a third party controller, the unit controller instructs the unit to maintain a heating discharge air temperature set point. The unit controller has direct control over the rooftop unit heating staging operation. The unit controller receives discharge supply air temperature information directly from the temperature sensor located in the supply duct. Based on this information, the unit controller activates the different heating stages to maintain the discharge supply air temperature set point (110°F default). Turning on additional heating stages increases the heating capacity, while turning off heating stages decreases the heating capacity. The heating discharge air temperature set point resides in the unit controller, has a factory default setting, and may be adjusted at start up. The user can adjust the set point either locally or remotely with Lennox' L Connection Network Unit Controller software or at the unit controller board. The user can not adjust the set point through a third party control device or software program.

19.1.6.6. Heating Operation (Electric)

Units feature multiple electric heat sections available in sizes from 30 kW to 180 kW (depending on unit size and voltage). Units can provide up to four stages of mechanical heating depending on the size of the electric heater. Staged operation occurs similar to cooling operation, with the unit controller activating or deactivating sections of the electric heater to maintain the discharge air temperature set point.

19.1.7. Constant Air Volume (CAV) Units in Single Zone Applications with a Thermostat or Third Party Unit Controller (2 Heat / 2 Cool)

19.1.7.1. Unit Controller Operation

When using a third-party unit controller and the unit controller is operating in the thermostat mode, a packaged rooftop unit can provide up to two stages of mechanical heating and cooling operation. To operate correctly, a unit controller must provide the following wiring connections to the unit controller:

1. Ventilation demand
2. Occupied demand
3. Heating demand one
4. Heating demand two
5. Cooling demand one
6. Cooling demand two

In this configuration the third party unit controller will control the rooftop unit staging and general operation. The unit controller functions primarily to determine unit error codes, provide diagnostic information and maintain safe operating limits.

19.1.7.2. Unit Sequence Of Operation

Constant air volume units in bypass zoning applications featuring a Lennox or third party unit controller with the unit controller operating in thermostat mode, have the same basic heating and cooling unit sequence of operations as constant air volume units in single zone applications featuring a third party unit controller, with the unit controller operating in thermostat mode. For specific information, refer to the Constant Air Volume in Single Zone Applications with a Thermostat or Third Party Unit Controller section.

The following sequence of operation information is specific to constant air volume units in bypass zoning applications.

19.1.7.3. Supply Duct Bypass Damper

To maintain accurate supply duct static pressure control, constant volume units in bypass zoning applications use a bypass damper between the supply and return air ducts. In this scenario, the supply duct static pressure transducer and damper connect directly to the third party unit controller. Based on actual static pressure relative to set point, the third party unit controller either modulates open or closes the damper. If the damper modulates further closed, the static pressure in the supply air duct increases. If the damper modulates further open, the static pressure in the supply air duct decreases. The unit controller does not have direct control over the bypass damper in this scenario.

19.1.8. Constant Air Volume Units in Bypass (CAVB) Zoning Applications with a Third Party Unit Controller and the Unit Operating in Discharge Air Temperature Control (4 Heat / 4 Cool)

19.1.8.1. Unit Controller Operation

When using a third party unit controller and the unit controller is operating in thermostat mode and configured for discharge air temperature control, a packaged rooftop unit can provide up to four stages of mechanical heating and cooling operation. To operate correctly, a third party unit controller must provide the following wiring connections to the unit controller:

1. Ventilation demand
2. Occupied demand

3. Heating demand
4. Cooling demand

In this configuration, the unit controller controls the rooftop staging and general operation. The third party unit controller only informs the unit controller as to whether or not there is a specific demand. For example, if the third party unit controller passes along a demand for cooling, then the unit controller increases or decreases cooling stages to maintain the discharge supply air temperature set point. Along with controlling the rooftop unit, the unit controller also determines error codes, provides diagnostic information and maintains safe operating limits.

19.1.8.2. Unit Sequence of Operation

Constant air volume units in bypass zoning applications featuring a third party unit controller with the unit controller operating in thermostat mode, configured for discharge air temperature control have the same basic heating and cooling unit sequence of operations as constant air volume units in single zone applications featuring a third party unit controller, with the unit controller operating in thermostat mode with discharge air temperature control.

For specific unit sequence of operation information refer to the Constant Air Volume Units in Single Zone Applications with a Thermostat or Third Party Unit Controller and the Unit Operating in Discharge Air Temperature Control section.

The following sequence of operation information is specific to constant air volume units in bypass zoning applications.

19.1.8.3. Supply Duct Bypass Damper

To maintain accurate supply duct static pressure control, constant volume units in bypass zoning applications typically feature a bypass damper between the supply and return air ducts. In this scenario, the supply duct static pressure transducer and damper connect directly to the third party unit controller. Based on actual static pressure relative to set point, the unit controller either modulates open or modulates closed the bypass damper.

If the damper modulates further closed, the static pressure in the supply air duct increases. If the damper modulates further open, the static pressure in the supply air duct decreases. The unit controller does not have any direct control over the bypass damper in this scenario.

19.1.9. Variable Air Volume (VAV) Units in Zoning Applications with a Third Party Unit Controller and the Unit Operating in Discharge Air Temperature Control (4 Heat / 4 Cool)

19.1.9.1. Unit Controller Operation

When using a third party unit controller with the unit controller operating in thermostat mode configured for discharge air temperature control, a packaged rooftop unit can provide up to four stages of mechanical heating and cooling operation. To operate correctly, a third party unit controller must provide the following wiring connections to the unit controller:

1. Ventilation demand
2. Occupied demand
3. Heating demand
4. Cooling demand

In this configuration, the unit controller controls the rooftop unit staging and general operation. The third party unit controller only informs the unit controller as to whether or not there is a specific demand. For example, if the unit controller passes along a demand for cooling, then the unit controller increases or decreases cooling stages to maintain the discharge supply air temperature set point. In this mode, the unit controller also maintains the supply duct static pressure by directly controlling the supply fan variable frequency drive. Along with providing control of the rooftop unit, the unit controller determines error codes, supplies diagnostic information and maintains safe operating limits.

19.1.9.2. Ventilation Demand

Upon receiving a ventilation demand from the unit controller, the unit controller instructs the supply fan variable frequency drive to start the supply fan and maintain a constant supply duct static pressure set point. The unit controller has direct control over the variable frequency drive and supply fan.

The unit controller receives supply duct static pressure information directly from a supply duct static pressure sensor located approximately three quarters down the length of the longest main supply duct. Based on information from the supply duct static pressure transducer relative to set point, the unit controller instructs the variable frequency drive to either increase or decrease the speed of the supply fan. Speeding up the supply fan will increase the supply duct static pressure while slowing down the supply fan speed will decrease the supply duct static pressure. For increased flexibility, the unit controller has separate, adjustable static pressure set points for ventilation, cooling, heating and smoke alarms. These set points reside in the unit controller memory, have factory default settings and may be adjusted in the field prior to start-up.

19.1.9.3. Cooling Demand

Upon receiving a cooling demand from the unit controller, the unit controller instructs the unit to maintain a cooling discharge air temperature set point. The unit controller has direct control over the rooftop unit staging. The unit controller receives discharge supply air temperature information directly from the supply duct temperature sensor located in the supply duct system. Based on this information, the unit controller turns on or off the different compressor stages to maintain the discharge supply air temperature set point (55°F default). Increasing compressor stages provides more cooling capacity while decreasing compressor stages provides less cooling capacity.

Energence units feature four separate compressor and refrigeration circuits that can provide up to four stages of mechanical cooling operation.

- For stage one operation, the unit controller activates the first compressor (25% of total unit capacity).
- For stage two operation, the unit controller activates the second compressor (50% unit capacity).
- For stage three operation, the unit controller activates the third compressor (75% total unit capacity).
- For stage four operation, the unit controller activates the fourth compressor (100% unit capacity).

The discharge supply air temperature set point resides in the unit controller, has a factory default setting, and can be adjusted at start-up. The user can adjust the set point either locally or remotely with the L Connection Network Unit Controller software or at the unit controller board. The user cannot adjust the set point through a third party control device or software program.

19.1.9.4. Cooling Demand With Economizer

If outdoor air is suitable for free cooling and the unit has an economizer, the unit controller opens the economizer and uses fresh air for stage one cooling.

- For stage two operation, the unit controller activates one compressor.
- For stage three operation, the unit controller activates a second compressor.
- For stage four operation, the unit controller activates the remaining compressors (number three and four).

The unit controller has direct control over the rooftop unit staging and economizer operation.

19.1.9.5. Heating demand (general operation)

Upon receiving a heating demand from the third party unit controller, the unit controller instructs the unit to maintain a heating discharge air temperature set point. The unit controller has direct control over the rooftop unit heating staging operation. The unit controller receives discharge supply air temperature information directly from the supply duct temperature sensor located in the supply duct system. Based on this information, the unit controller turns on or off mechanical heating stages to maintain the discharge supply air temperature set point (110°F default). Adding heat stages increases heat capacity while removing heat stages decreases heat capacity.

The heating discharge air temperature set point resides in the unit controller, has a factory default setting, and may be adjusted at start up. The user can adjust the set point either locally or remotely with the L Connection Network Unit Controller software. The user cannot adjust the set point through a third party control device or software program.

19.1.9.6. Heating Operation (Electric)

Energence units feature multiple electric heat sections available in sizes from 30 kW to 180 kW (depending on unit size and voltage). Units can provide up to four stages of mechanical heating depending on the size of the electric heater. Staged operation occurs similar to cooling operation, with the unit controller activating or deactivating sections of the electric heater to maintain the discharge air temperature set point.

19.1.9.7. Morning Warm Up

Energence units have an intelligent and innovative morning warm up control scheme. As the VAV system shifts from unoccupied to occupied, the unit controller automatically keeps the economizer shut for 60 minutes (default) or until the first cooling demand. On cold days this prevents unconditioned fresh outdoor air from entering the building and helps to reduce energy usage. Because most VAV systems perform morning warm up before occupants enter the building, the absence of fresh outdoor air typically does not cause any problems.

Upon the first call for heating in this scenario, the unit controller instructs the unit to turn on the heating section and start supply fan operation. Because the unit controller controls the heat staging and supply fan operation based on actual discharge supply air temperature control and supply duct static pressure, the rooftop unit automatically selects the proper staging and supply fan speed to ensure optimal performance.

Typically in this scenario all zones are below the desired room temperature set point so the VAV boxes will be fully open. This causes the supply duct static pressure to be low so the unit controller speeds up the fan to maintain the supply duct static pressure set point. As the supply fan speeds up and increases the total supply air volume, the heating section turns on additional stages to maintain the correct discharge supply air temperature set point. In the event the unit controller receives a call for cooling from the third party unit controller, the unit controller switches to cooling mode and opens the economizer. This intelligent control scheme helps prevent potential problems caused by stuck VAV box dampers and supply duct static over pressurization.

19.1.9.8. Outdoor Air CFM Control

The Outdoor Air CFM Control option allows variable air volume units to minimize the effect of supply fan speed changes and maintain a constant outdoor air CFM level. A sensor located in the outdoor air section of the unit measures the outdoor air velocity and relays the information to the unit controller. Based on the velocity information, the unit controller automatically adjusts the economizer position, offsetting the supply fan speed changes and maintaining a constant outdoor air CFM level.

20. M2 Unit Controller Inputs and Outputs

When necessary, individual inputs and outputs may be read at the M2 board connectors. M2 boards are shown on wiring diagrams as dashed boxes (see shaded areas in figure 40). Parts of the M2 boards will be located in all wiring diagram sections (see Page 103 for connector information and description and type of input or output).

Example: To Determine If 24 Volts Is Being Supplied To The K3 Blower Contactor:

1. Using the unit wiring diagram, locate K3 and identify appropriate M2 board and jack/plug. (A55 Main Board and P265-4.)
2. Find the I&O table for P265-4 ; it shows a 24 volt output to the blower.

△1 S42 USED ON "M" VOLTAGE UNITS AND UNITS WITH HIGH EFFICIENCY MOTORS

△2 ONLY ON UNITS WITH HUMIDITROL OPTION

△3 EXTERNAL HUMIDITROL CONTACTS

△4 CONNECTS TO SECTION "A" HEATING DIAGRAM. MAY BE LOCATED IN HEATING COMPARTMENT

△5 S49 AND S50 ARE PART OF 5VDC CIRCUIT

△6 F37 AND F38 ARE NOT USED ON UNITS LESS ELECTRIC HEAT, 480 AND 600V

△7 F37 AND S39 PRESSURE SWITCH CONTROL

△8 VOLTAGE CONTROL SINGLE STAGE

△9 VOLTAGE CONTROL TWO STAGE

△10 REMOVE JUMPER BETWEEN TB24-28 AND TB24-29 WHENEVER ALC CONTROL IS USED. REFER TO SECTION C DIAGRAM

△11 A30 SENSOR AND A96 INVERTER CONTROL FOR B3 SUPPLY AIR BLOWER

△12 A34 SENSOR AND A137 INVERTER CONTROL FOR B35 AND B36 EXHAUST AIR BLOWERS

△13 A30 MAY BE USED WITH OR WITHOUT A34
A34 MAY BE USED WITH OR WITHOUT A30
A34 MAY BE USED WITH OR WITHOUT B9 BYPASS DAMPER
A34 MAY BE USED WITH EITHER A96 VFD OR B9 BYPASS DAMPER

△14 MITSUBISHI VFD

△15 K202-1 CONTACTOR MAY BE OMITTED ON UNITS WITH VFD OPERATION ONLY

△16 USED ON VFD APPLICATIONS

NOTE - IF ANY WIRE IN THIS APPLIANCE IS REPLACED, IT MUST BE REPLACED WITH WIRE OF LIKE SIZE, RATING, TERMINATION AND INSULATION THICKNESS.

WARNING - ELECTRIC SHOCK HAZARD! CAN CAUSE INJURY OR DEATH. UNIT MUST BE GROUNDED IN ACCORDANCE WITH NATIONAL AND LOCAL CODES.

DISCONNECT ALL POWER BEFORE SERVICING.

DENOTES OPTIONAL COMPONENTS
LINE VOLTAGE FIELD INSTALLED

DESCRIPTION	
KEY	COMPONENT
A30	SENSOR, PRESSURE DISCHARGE AIR
A34	SENSOR, PRESSURE RETURN AIR
A55	PANEL, MAIN PANEL LENNOX
A59	PANEL, COMPRESSORS 3 AND 4
A96	CONTROL, INVERTER SUPPLY
A133	PANEL, GP BOARD LENNOX
A137	CONTROL, INVERTER RETURN
B1	COMPRESSOR 1
B2	COMPRESSOR 2
B3	MOTOR, BLOWER
B4	MOTOR, OUTDOOR FAN 1
B5	MOTOR, OUTDOOR FAN 2
B13	COMPRESSOR 3
B20	COMPRESSOR 4
B21	MOTOR, OUTDOOR FAN 3
B22	MOTOR, OUTDOOR FAN 4
B23	MOTOR, OUTDOOR FAN 5
B24	MOTOR, OUTDOOR FAN 6
B35	MOTOR, EXHAUST BLOWER 1
B36	MOTOR, EXHAUST BLOWER 2
CB8	CIRCUIT, BREAKER T1
CB10	CIRCUIT BREAKER, MAIN DISCONNECT UNIT
CB18	CIRCUIT, BREAKER T18
F10	FUSE, OUTDOOR FAN MOTOR
F30	FUSE, TRANSFORMER T29 PRIMARY
F31	FUSE, TRANSFORMER T29 SECONDARY
F37	FUSE, COMPRESSOR GROUP 1
F38	FUSE, COMPRESSOR GROUP 2
HR1	HEATER COMPRESSOR 1
HR2	HEATER COMPRESSOR 2
HR5	HEATER COMPRESSOR 3
HR11	HEATER COMPRESSOR 4
J11	JACK, GFI, RECEPTACLE
J86	JACK, OUTDOOR FAN INTERFACE
J87	JACK, OUTDOOR FAN INTERFACE 2
J118	JACK, COMPRESSOR 3 AND 4, CONTROL
J119	JACK, COMPRESSOR 3 AND 4, INPUT
J132	JACK, BLOWER, EXHAUST FAN MOTOR 1
J133	JACK, BLOWER, EXHAUST FAN MOTOR 2
J138	JACK, EXHAUST FAN 2
J139	JACK, EXHAUST FAN 3
J194	JACK, I/O FOR A133 LENNOX A133 BOARD
J211	JACK, INVERTER EXHAUST BLOWER
J248	JACK, VFD CONTROL
J258	JACK, VFD CONTROL EXHAUST AIR
J263	JACK, HIGH AND LOW PRESSURE SWITCHES
J264	JACK, BLOWER DECK
J265	JACK, CONTACTORS AND RELAYS
J267	JACK, OUTDOOR FAN AREA
J268	JACK, TRANSFORMER 1 POWER
J269	JACK, HUMIDITROL
J299	JACK, HUMIDITROL INTERFACE
K1,-1	CONTACTOR, COMPRESSOR 1
K2,-1	CONTACTOR, COMPRESSOR 2
K3,-1	CONTACTOR, BLOWER

K10,-1,2	RELAY, OUTDOOR FAN 1
K14,-1	CONTACTOR, COMPRESSOR 3
K68,-1	RELAY, OUTDOOR FAN 2
K146,1	CONTACTOR, COMPRESSOR 4
K149,-1	RELAY, OUTDOOR FAN 3
K150,-1	RELAY, OUTDOOR FAN 4
K152,-1	RELAY, OUTDOOR FAN 5
K153,-1,2	RELAY, OUTDOOR FAN 6
K199,-1	CONTACTOR, EXHAUST BLOWER 1
K201,-1	CONTACTOR, EXHAUST BLOWER 2
K202,-1	CONTACTOR, INVERTER BLOWER
K203,-2	RELAY, SUPPLY BLOWER AUX
K207,-2	RELAY, EXHAUST BLOWER AUX
L14	VALVE, SOLENOID REHEAT COIL 1
L30	VALVE, SOLENOID REHEAT COIL 2
P86	PLUG, OUTDOOR FAN INTERFACE
P87	PLUG, OUTDOOR FAN INTERFACE 2
P118	PLUG, COMPRESSOR 3 AND 4, CONTROL
P119	PLUG, COMPRESSOR 3 AND 4, INPUT
P194	PLUG, I/O FOR A133 LENNOX A133 BOARD
P211	PLUG, INVERTER EXHAUST BLOWER
P248	PLUG, VFD CONTROL
P258	PLUG, VFD CONTROL EXHAUST AIR
P263	PLUG, HIGH AND LOW PRESSURE SWITCHES
P264	PLUG, BLOWER DECK
P265	PLUG, CONTACTORS AND RELAYS
P267	PLUG, OUTDOOR FAN AREA
P268	PLUG, TRANSFORMERS
P269	PLUG, HUMIDITROL
P299	PLUG, SAFETY
RT17	SENSOR, OUTDOOR AIR
S4	SWITCH, LIMIT HI PRESS COMPRESS 1
S7	SWITCH, LIMIT HI PRESS COMPRESS 2
S11	SWITCH, LOW PRESS, LOW AMBIENT KIT COMP 1
S28	SWITCH, LIMIT HI PRESS COMPRESS 3
S37	SWITCH, PRESSURE EXHAUST FAN
S39	SWITCH, EXHAUST FAN
S42	SWITCH, OVERLOAD RELAY BLOWER MOTOR
S48	SWITCH, DISCONNECT
S49	SWITCH, FREEZE STAT COMPRESS 1
S50	SWITCH, FREEZE STAT COMPRESS 2
S53	SWITCH, FREEZE STAT COMPRESS 3
S84	SWITCH, LOW PRESS, LOW AMBIENT KIT COMP 2
S85	SWITCH, LOW PRESS, LOW AMBIENT KIT COMP 3
S87	SWITCH, LOW PRESS, COMP 1
S88	SWITCH, LOW PRESS, COMP 2
S94	SWITCH, LOW PRESS, LOW AMBIENT KIT COMP 4
S95	SWITCH, FREEZE STAT COMPRESS 4
S96	SWITCH, LIMIT HI PRESS COMPRESS 4
S97	SWITCH, LOW PRESS, COMP 4
S98	SWITCH, LOW PRESS, COMP 3
S117	SWITCH, GFI
T1	TRANSFORMER, CONTROL
T18	TRANSFORMER, CONTACTOR
T29	TRANSFORMER, GFI
TB13	TERMINAL STRIP, POWER DISTRIBUTION
TB18	TERMINAL STRIP, CYCLE CONTROL
TB23	TERMINAL STRIP, BLOWER SPEED
TB24	TERMINAL STRIP, UNIT ADDER
TB40	TERMINAL STRIP, COMPRESSOR 1
TB41	TERMINAL STRIP, COMPRESSOR 2
TB47	TERMINAL STRIP, COMPRESSOR 3
TB58	TERMINAL STRIP, EXHAUST FANS
TB59	TERMINAL STRIP, INVERTER BY-PASS

Wiring Diagram Key (see figure 40)

Table 44. M2 unit controller signal reference diagram

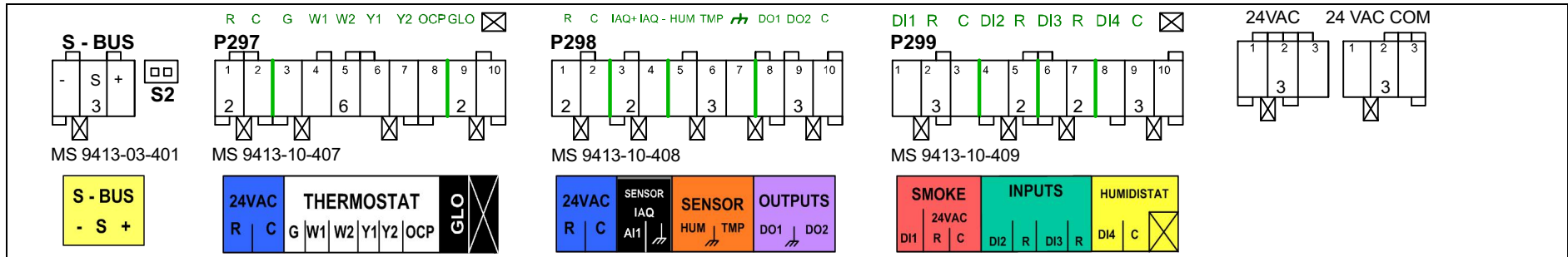

Pin #	Label	Description	Type	Description	Part Number
P297 Thermostat				Assembly	MS 9413-10-407
1	R	TRANSFORMER 1 24VAC POWER	24VAC	Header & Label	MS 9413-10-011
2	C	TRANSFORMER 1 24V COMMON	24V COMM	- Header	MSLO 9408-010-576-960-000-00
3	G	BLOWER SIGNAL	24VAC DI	- Label	MZ 9400-10-007
4	W1	1ST STAGE HEATING	24VAC DI	Screw terminal	MF 9306-002-0A-002-G
5	W2	2ND STAGE HEATING	24VAC DI	Screw terminal	MF 9306-006-43-000-G
6	Y1	1ST STAGE COOLING	24VAC DI	Screw terminal	MF 9306-002-49-000-G
7	Y2	2ND STAGE COOLING	24VAC DI		
8	OCP	OCCUPIED SIGNAL	24VAC DI		
9	GLO	GLOBAL CONTROL INPUT	24VAC DI		
10	RSV	RESERVED	NA		
P298 IAQ Interface				Assembly	MS 9413-10-408
1	R	TRANSFORMER 1 24VAC POWER	24VAC	Header & Label	MS 9413-10-012
2	C	TRANSFORMER 1 24V COMMON	24V COMM	- Header	MSLO 9408-S10-000
3	IAQ+	INDOOR AIR QUALITY	0-10VDC AI	- Label	MZ 9400-10-008
4	GND	INDOOR AIR QUALITY	0-10VDC AI	Screw terminal	MF 9306-002-60-000-G
5	HUM	RH SENSOR	0-10VDC AI	Screw terminal	MF 9306-002-64-000-G
6	GND	DIGITAL GROUND	GND	Screw terminal	MF 9306-003-4D-000-G
7	TMP	ZONE SENSOR	0-10VDC AI	Screw terminal	MF 9306-003-4L-000-G
8	DO1	SERVICE RELAY OUTPUT	24VAC DO		
9	GND	24 VAC COMMON	24V COMM		
10	DO2	EXHAUST FAN	24VAC DO		
P299 Safety				Assembly	MS 9413-10-409
1	DI1	SMOKE DETECTOR (NO)	24VAC DI	Header & Label	MS 9413-10-013
2	R	TRANSFORMER 1 24VAC POWER	24VAC	- Header	MSLO 9408-010-075-960-000-00
3	C	TRANSFORMER 1 24V COMMON	24V COMM	- Label	MZ 9400-10-009
4	DI2	DIGITAL INPUT 2 FORMER (S42 & S135)	24VAC DI	Screw terminal	MF 9306-003-0H-000-G
5	R	TRANSFORMER 1 24VAC POWER	24VAC	Screw terminal	MF 9306-002-0P-002-G
6	DI3	DIGITAL INPUT 3 FORMER (S149 & A42 FOR A BOX)	24VAC DI	Screw terminal	MF 9306-002-37-001-G
7	R	TRANSFORMER 1 24VAC POWER	24VAC	Screw terminal	MF 9306-003-01-000-G
8	DI4	DIGITAL INPUT 4 FORMER (HUMIDITROL INPUT)	24VAC DI		
9	C	TRANSFORMER 1 24V COMMON	24V COMM		
10	RSV	RESERVED	NA		

Alphabetical Index

Abbreviations	Page 106
BACnet™ Module	Page 55
Diagnostics	Page 62
Discharge Air Control	Page 42
Economizer	Page 25
ECTO Electronic Configure To Order Control	Page 66
Inputs and Outputs	Page 100
Load Shedding Options	Page 59
LonTalk™ Module	Page 54
Low Ambient Fan Cycling	Page 17
Main Controller Operation	Page 7
Modulating Gas Valve (MGV)	Page 58
Networking the Controllers	Page 89
PID Loop Operation	Page 40
Power Exhaust Operation	Page 34
Prodigy M2 Unit Controller Description	Page 6
Reheat Operation	Page 19
Sensors	Page 15
Sequence of Operation	Page 90
Service Relay Operation	Page 60
Supply Air Delivery	Page 36
Third Party Zoning	Page 48
Unit Component Operation	Page 12



Abbreviations

A55	M2 board. Main RTU control board	IDE	Indoor enthalpy. Depends on temperature and humidity
A133	GP1 Board. General purpose add-on board DIP selects 3 functions	"w.c.	Inches of water column
A169	MCB1 board. A Box motor control board.	LED	Light emitting diode. An indicator light, found either as individual elements or grouped together as segments to form characters
AI	Analog input	LP	Low pressure
AO	Analog output	LT	Limit
BL	Blower	M2	M2 Unit Controller - main controller board (A55). Firmware version 7.00.00 or later.
C2	2nd compressor add-on board (A59)	MCB1	A Box motor control board (A169).
C1	1st stage cooling	MGV	Modulating gas valve
C2	2nd stage cooling	MSAV	Multi Stage Air Volume
C3	3rd stage cooling	OAC	Outdoor air control
C4	4th stage cooling	OAS	Outdoor air suitable for free cooling
CAI	Combustion air inducer	OAT	Outdoor air temperature
CAVB	Constant air volume with bypass damper	OCP	Thermostat demand, occupied mode
COM	Electrical common	ODE	Outdoor enthalpy. Depends on temperature and humidity
CL	Cooling	PID	Proportional, integral and derivative based control loop
CP1	Compressor 1	PPM	Parts per million (mostly used for CO ₂ measurements)
CP2	Compressor 2	RAP	Return air pressure
CP3	Compressor 3	RAT	Return air temperature
CP4	Compressor 4	RH	Relative humidity
CSP	Cooling setpoint	RS	Reset
DAC	Discharge (supply) air control	RTU	Roof top unit
DACC	Discharge (supply) air control cooling	RT6	Discharge air temperature sensor
DACH	Discharge (supply) air control heating	RT16	Return air temperature sensor
DAP	Discharge (supply) air pressure	RT17	Outdoor air temperature sensor
DAT	Discharge (supply) air temperature	SMK	Smoke detection mode (alarm)
DB	Deadband	SP	Setpoint
DCV	Demand controlled ventilation	Stg	Stage
DI	Digital input	TB	Terminal block
Diff	Differential	UnOCP	Unoccupied
DIP	DIP switch	W1	Thermostat demand, heat stage 1
DO	Digital output	W2	Thermostat demand, heat stage 2
ECTO	Electronic configure to order (control parameters)	W3	Thermostat demand, heat stage 3
FAC	Fresh air cooling control	W4	Thermostat demand, heat stage 4
FAH	Fresh air heating control	VAC	Alternating current voltage
FAT	Fresh air tempering control. See FAC & FAH	VAV	Variable air volume. Accomplished with a variable frequency drive (VFD)
FC	Free cooling	VDC	Direct current voltage
G	Thermostat demand, blower	VFD	Var. frequency drive. An AC inverter used to vary motor speed
GLO	Global mode or input (economizer)	VT	Ventilation
GP1	General purpose board GP1-1 (A133)	Y1	Thermostat demand, cooling stage one
H1	1st stage heating	Y2	Thermostat demand, cooling stage two
H2	2nd stage heating	Y3	Thermostat demand, cooling stage three
H3	3rd stage heating	Y4	Thermostat demand, cooling stage four
H4	4th stage heating	ZAT	Zone air temperature
HP	High pressure		
HSP	Heating setpoint		
HT	Heating		
IAQ	Indoor air quality. Often synonymous with CO ₂ level in ppm		